

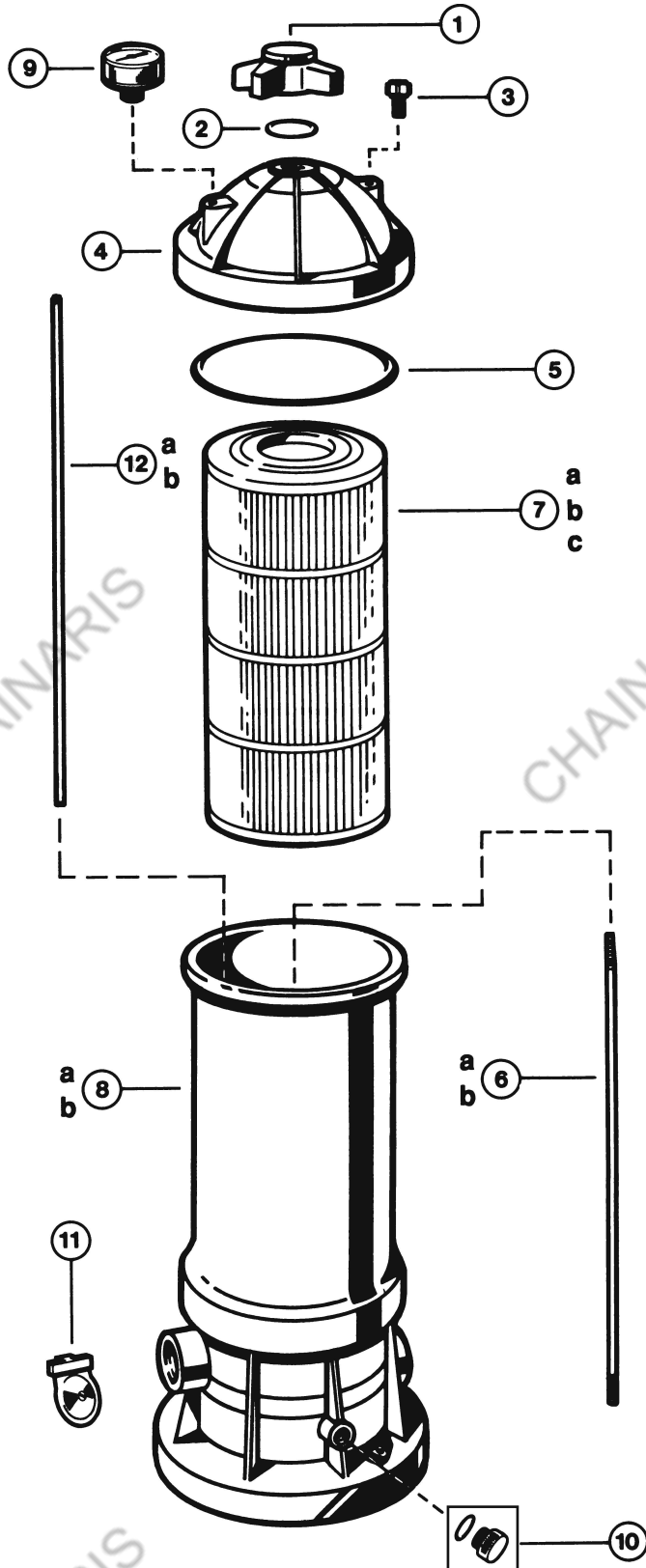

Star-Clear II™

CARTRIDGE FILTER SERIES AND SEPARATION TANK REPLACEMENT PARTS

Parts Diagram



STAR-CLEAR II SELECT-A-SYSTEMS

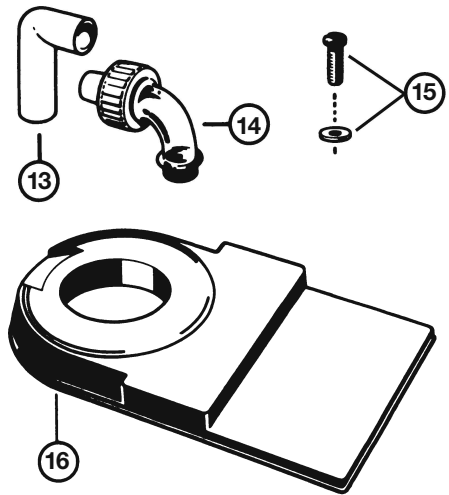

Filters

Parts Listing

Ref. No.	Part No.	Description	Ctn. Qty.	No. Req'd
1	CX800G	Locking Knob	5	1
2	CX250Z7	O-Ring	10	1
3	ECX1322A	Directional Vent Valve with O-Ring	25	1
4	CX800C	Filter Head (Cover) with Air Relief Valve	2	1
5	CX800F	Filter Head O-Ring	10	1
6a	CX800Z2	Tie Rod (C800)	1	1
6b	CX1100Z2	Tie Rod (C1100)	1	1
7a	CX800RE	Cartridge Element (C800)	1	1
7b	CX1100RE	Cartridge Element (C1100)	1	1
7c	CX800RE	Cartridge Element (C1500) – 2 Required	1	2
—	CX1500C	Cartridge Joiner (to join two C800RE cartridges in C1500 Filter)	5	1
8a	CX800AA*	Filter Tank Body – 1 1/2" (C800)	1	1
8b	CX1500AA*	Filter Tank Body – 1 1/2" (C1500)	1	1
9	ECX27091	Pressure Gauge	10	1
10	CX250Z14A	Drain Plug Kit (Includes Plug and O-Ring)	10	1
11	CX800HA	Check Valve Assembly (optional)	10	1
12a	CX800Z4	Auto Air Relief Tube (C800)	2	1
12b	CX1100Z4	Auto Air Relief Tube (C1100)	2	1

Modular Selecta-Systems

13	ECX1326A	Flex Loop Elbow	5	1
14	SPX14853	Sweep Elbow Union Assembly	5	1
15	ECX1108A	5/16" x 3/4" Mounting Screws (2) and 5/16" Washers (2) Kit	10	1
16	EC1161PAK	Platform Base with Screws – Low Profile	1	1

D.E. SEPARATION TANK Parts are same as C1100 except replace cartridge element with bag below.

—	CX1100DB	D.E. Collector Bag Assembly	1	1
---	----------	-----------------------------	---	---

NOTE: *1 1/2" NPT ports are standard. Add suffix 2 to part number for 2" NPT ports or 2S for 2" socket connections.