

# Galaxy Single-Element Cartridge Filter

DELIVER OPTIMAL SPARKING CLEAR WATER

For residential pool and spa



 **Emaux**  
water technology

Pool & Spa Equipment

**NEW**

# Product Features

## Deliver Optimal Sparking Clear Water

Galaxy Single-Element Cartridge Filter is built with high-strength and UV-resistant material to prolong the product life. The compact and low height design is suitable for any pool especially with limited system setup space. The extensive dirt-catching capability of the filter element makes this filter highly efficient. A reliable choice for crystal clear water.



## User friendly

- 4 x mounting holes
- Easy-grip lid handle
- Indicative pressure gauge tells you when to service
- Knee-height tank base facilitates easy cartridge replacement

## Trouble-free maintenance

- Locking ring with quick-release latch allows removing and installing the top tank quickly.
- Large water drain makes fast and easy winterisation.
- Simple cleaning and rinsing the filter element with a garden hose.

## Eco-Friendly

Big one-piece cartridge element provides a large filtration surface for trapping more dirt and debris. Less cleaning required, and unlike sand filters, needs no backwashing thus saving water and its precious chemicals.



## Product Information:

Code	Model	Filter Area		In / Outlet Connections	Max Flow Rate		A mm	B mm	C mm	D mm	E mm	F mm
9140401	ICF100	100 sqft	9.29m <sup>2</sup>	2"/2.5"	379 lpm	22.7m <sup>3</sup> /h	825	444.5	588	304	335	91
9140402	ICF150	150 sqft	13.94m <sup>2</sup>	2"/2.5"	455 lpm	27.3m <sup>3</sup> /h	910	444.5	588	304	335	91
9140403	ICF200	200 sqft	18.58m <sup>2</sup>	2"/2.5"	455 lpm	27.3m <sup>3</sup> /h	1033	444.5	588	304	335	91

## Cartridge Filter Element:

Code	Model	G mm	H mm	Micron µm	Fold Number
914100004	ICF100-CE	497	Ø267	15	137
914100005	ICF150-CE	590	Ø267	15	172
914100006	ICF200-CE	717	Ø267	15	187

Galaxy Series Filter is equipped with :

1. universal standard of union connection
2. pressure gauge
3. cartridge filter element

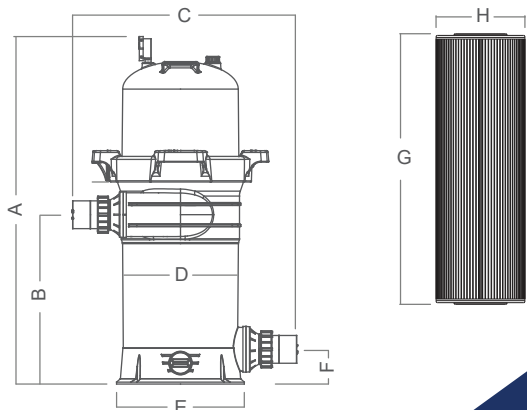

## EMAUX WATER TECHNOLOGY CO., LTD

ADDRESS: Flat A-D, 20/F., Kai Bo 22, 22 Wing Kin Road,  
Kwai Chung, HK

PHONE +852 2832 9880

[www.emauxgroup.com](http://www.emauxgroup.com)

 **YOUR PREMIER SUPPLIER**

**Available from:**



Chainaris Phuket Engineering Co., Ltd.

63/13 Moo.2, T.Vichit, A.Muang Phuket 83000

Tel: 076-513100-4

Fax: 076-513105

Line: @chainaris, @chainarishop

ALL SPECIFICATIONS ARE SUBJECT TO CHANGE WITHOUT NOTICE.  
© 2021 EMAUX WATER TECHNOLOGY CO., LTD. ALL RIGHTS RESERVED.

[www.emauxgroup.com](http://www.emauxgroup.com)