



Multi-stage submersible pumps



Construction

Multi-stage centrifugal submersible pumps with pump jacket in chrome-nickel stainless steel, with vertical delivery port. Motor cooled by the pumped water passing between the motor jacket and the external jacket. Double shaft seal with oil chamber.

Applications

- For clean water containing solids up to 2 mm grain size.
- For draining rooms or emptying tanks.
- Extraction of water from ponds, streams or pits and for rainwater collection.
- For irrigation purposes.

For outdoor use a power supply cable of not less than 10 m should be used in accordance with: EN 60 335-2-41.

Operating conditions

Liquid temperature up to 35° C.
Maximum immersion depth: 5 m.
Minimum water level with float 100 mm.
Continuous duty.

Motor

2-pole induction motor, 50 Hz ($n \approx 2900$ rpm).

MP: three-phase 230 V $\pm 10\%$;
three-phase 400 V $\pm 10\%$;

MPM: single-phase 230 V,
with float switch and thermal protector.
Incorporated capacitor.

Insulation class F.

Protection IP X8 (for continuous immersion)

Double impregnation humidity-proof dry winding.

Constructed in accordance with: EN 60034-1;

EN 60335-1, EN 60335-2-41.

Materials

Component	Material
Pump casing Impeller Stage casing	PPO-GF20 (Noryl)
Motor jacket Pump jacket	Chrome-nickel steel 1.4301 EN 10088 (AISI 304)
Strainer Handle	Polypropylene
Shaft	Chrome-nickel steel 1.4305 EN 10088 (AISI 303)
Mechanical seal	Ceramic alumina/Carbon/NBR
Seal lubrication oil	Oil for food/pharmaceutical machinery

Other features on request

- Other voltages.
- Frequency 60 Hz (as per 60 Hz data sheet).
- Other mechanical seal.
- Cable length 10 m.
- Vertical magnetic float switch.
- Motor suitable for operation with frequency converter.

Coverage chart $n \approx 2900$ rpm

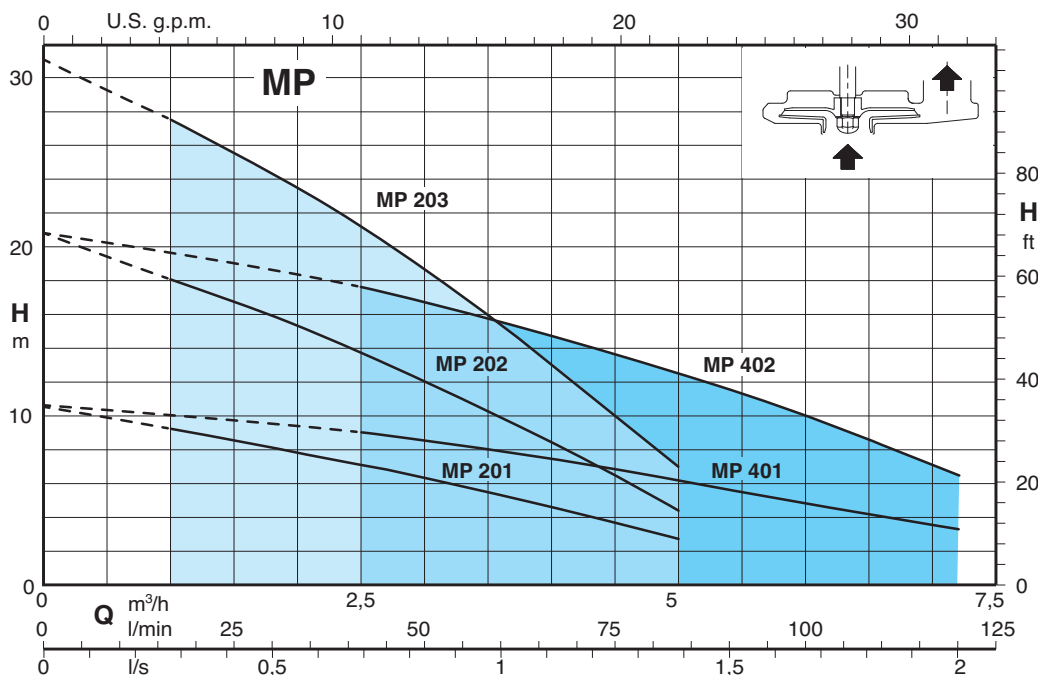

Performance $n \approx 2900$ rpm

3~	230V 400V		1~	230V Capacitor			P ₁	P ₂		Q	H									
	A	A		A	μf	Vc		kW	kW		HP	m ³ /h	0	1	1,5	2	2,5	3	3,5	4
MP 201	1,6	0,9	MPM 201	2,3	8	450	0,5	0,25	0,34	H	10,5	9,2	8,5	7,8	7,1	6,3	5,5	4,6	3,7	2,7
MP 202	1,6	0,9	MPM 202	2,3	8	450	0,5	0,25	0,34		20,7	18	16,7	15,3	13,7	12	10,2	8,4	6,4	4,4
MP 203	2,3	1,3	MPM 203	3,5	12,5	450	0,7	0,37	0,5		31	27,5	25,5	23,5	21,2	18,6	16	13	10	7

3~	230V 400V		1~	230V Capacitor			P ₁	P ₂		Q	H									
	A	A		A	μf	Vc		kW	kW		HP	m ³ /h	0	2,25	3	3,5	4	4,5	5	6
MP 401	1,6	0,9	MPM 401	2,3	8	450	0,5	0,25	0,34	H	10,6	9,2	8,5	8	7,4	6,8	6,2	4,8	3,3	-
MP 402	2,3	1,3	MPM 402	3,5	12,5	450	0,7	0,37	0,5		20,8	18	16,7	15,8	14,8	13,6	12,5	10	6,5	-

P₁ Max. power input.

P₂ Rated motor power output.

Density $\rho = 1000$ kg/m³.

Kinematic viscosity $\nu = \max 20$ mm²/sec.

Tolerances according to UNI EN ISO 9906:2012

Pump type	Power supply cable				Float switch	
	Cable material	Section	Length	Plug CEE 7(VII)	Cable material	Section
MPM 201,202,401	H05RN-F	3G0,75 mm ²	5 m	YES	H07RN-F	3G1 mm ²
MPM 203,402	H07RN-F	3G1 mm ²	5 m	YES	H07RN-F	3G1 mm ²
MP 201,202,401	H05RN-F	4G0,75 mm ²	5 m	NO	NO	-
MP 203,402	H07RN-F	4G1 mm ²	5 m	NO	NO	-

Dimensions and weights

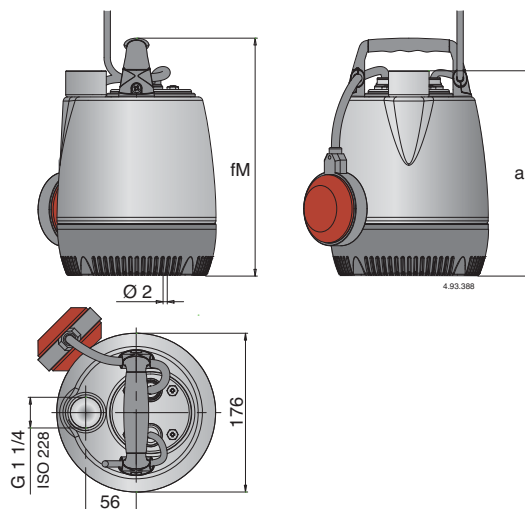

TYPE	Dimensions mm		(1) kg	
	fM	a	MP	MPM
MP 201 - MPM 201	265	230	4,7	4,9
MP 202 - MPM 202	290	255	4,8	5,2
MP 203 - MPM 203	350	315	6,4	6,7
MP 401 - MPM 401	265	230	4,7	4,9
MP 402 - MPM 402	325	290	6	6,4

(1) With cable length: 5 m

Installation examples

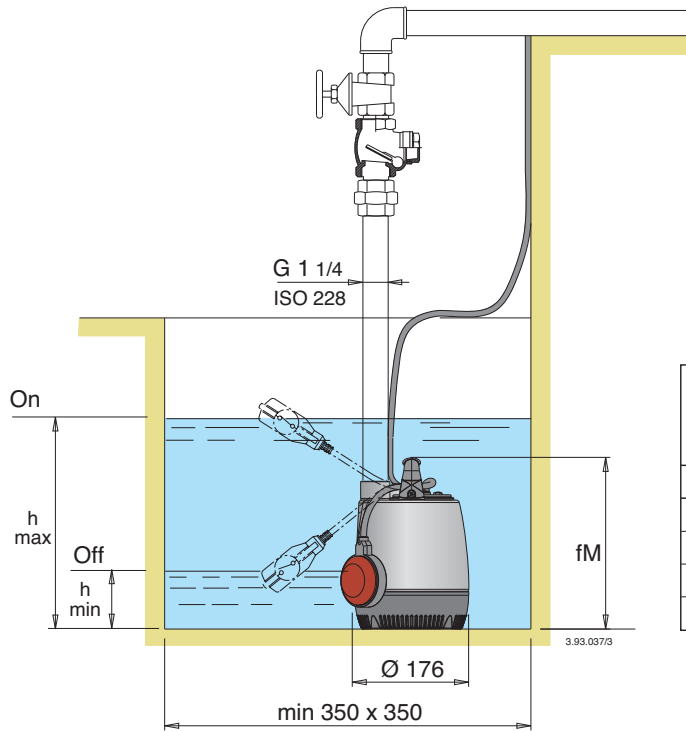

TYPE	mm	
	h min	h max
MPM 201	100	310
MPM 202	125	335
MPM 203	185	395
MPM 401	100	310
MPM 402	160	370

Installation examples with vertical magnetic float switch

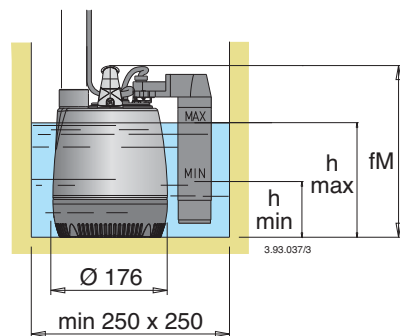

TYPE	mm	
	h min	h max
MPM 201 GF	100	190
MPM 202 GF	125	315
MPM 203 GF	185	275
MPM 401 GF	100	190
MPM 402 GF	160	250

Features

G 1 1/4 vertical, upward delivery port for installation in small pits, without the need for an elbow on the pump.

Handle in polypropylene.

Easy inspection of the capacitor area.

Shaft in chrome-nickel stainless steel.

Motor cooled by the pumped water passing between the motor jacket and the external jacket.

Ceramic stainless steel shaft sleeve.

Oil chamber.

Easy adjustment of the float switch: to allow the adjustment of start/stop pump levels.

Suction strainer that allows the passage of solids up to 2 mm.

Stage casing and Impeller in PPO-GF20 (Noryl)

The double shaft seal with oil chamber separates the motor from the water and provides further protection against accidental operation when dry.

