



4" Spin Klin™ Galaxy

Automatic disc filtration system for high flow rates



inlet/outlet connection

200 - 400 mm
(8" - 16")

flow rates

200 - 3000 m³/h
(880 - 13200 gpm)

filtration degrees

55 - 400
micron

max. working pressure

10 bar
(145 psi)

features:

- Micron-precise depth filtration of solids
- Innovative disc technology captures and retains large amounts of solids
- Long-term operation with minimal maintenance
- Easy and simple operation
- Short automatic backwash with regulated water volume for a small water footprint
- Permanently eliminates the need to replace filter media
- Compact design

How the 4" Galaxy Systems Work

General

The Galaxy 4" Spin Klin™ series are modular, all polymeric, automatic disc filters with a patented self-cleaning backwash mechanism. The 4" Galaxy systems range in flow rates from 200 m³/h (880 gpm) to 3,000 m³/h. (13,200 gpm) with filtration degrees ranging from 55 – 400 micron. Inlet/Outlet from 200 - 400 mm (8" – 16") diameter.

The Filtration Process

The discs are stacked on the Spin Klin™ spine and assembled according to pre-determined water filtration requirements. During filtration, the discs are compressed by means of a pre-loaded spring and differential pressure, forcing the water to pass through the grooved disc surface, thus trapping the solids.

The Backwash Process

Activated by a pre-determined time command or differential pressure, the system enters backwash mode. The inlet valve port shuts as the drain valve port opens. During the backwash process, pressure is released and the spine's piston elevates, releasing the compression on the discs. Tangential jets of filtered water are then forced through the nozzles positioned along the spine. At this stage the discs spin freely, loosening the trapped solids which are then flushed out. During the flushing cycle each filter pod is backwashed sequentially, while the other pods continue to supply filtered water downstream. When a pod begins the backwash cycle, the system valves automatically reverse the flow in the pod, allowing filtered downstream pressurized water to backwash the filter.

Construction materials	
Filter Housing & Lid	RPA (Reinforce Polyamide) & RPP (Reinforce Polypropylene)
Disc elements	PP (Polypropylene) or PA (Polyamide)
Backwash valves	RPA (Reinforce Polyamide)
Manifolds	PP (Polypropylene)
Seals	NBR or EPDM, (Viton optional)
Control Tubing	PE or PA

Disc material type availability according to filtration degree:

Color Code	Gray	Purple	Green	Brown	Black	Red	Yellow	Blue
Micron	20	40	55	70	100	130	200	400
PP Disc PA [Nylon] Disc	PP, PA	PP	PP, PA	PP, PA	PP, PA	PP, PA	PP, PA	PP

Filter Type	3 unit battery	4 unit battery	5 unit battery	6 unit battery	7 unit battery	8 unit battery
-------------	----------------	----------------	----------------	----------------	----------------	----------------

General Data							
Max. working pressure*	10 bar (145 psi)						
Min. backwash pressure	2.8 bar (30 psi)						
Maximum recommended flow rate	130µ	225 m³/h (990 gpm)	300 m³/h (1,321 gpm)	375 m³/h (1,651 gpm)	450 m³/h (1,981 gpm)	525 m³/h (2,312 gpm)	600 m³/h (2,642 gpm)
Filtration volume		17,219 cm³ (1,051 in³)	22,959 cm³ (1,401 in³)	28,698 cm³ (1,751 in³)	34,438 cm³ (2,101 in³)	40,177 cm³ (2,451 in³)	45,918 cm³ (2,802 in³)
Filtration area		13,200 cm² (2,046 in²)	17,600 cm² (2,728 in²)	22,000 cm² (3,410 in²)	26,400 cm² (4,092 in²)	30,800 cm² (4,774 in²)	35,200 cm² (5,456 in²)
Inlet/Outlet diameter		200 mm (8")	250 mm (10")	250 mm (10")	300 mm (12")	300 mm (12")	350mm (14")
Max. working temperature*	60°C (140°F)						
Dry weight standard		270 kg (594 lb)	350 kg (770 lb)	440 kg (968 lb)	530 kg (1,166 lb)	670 kg (1,447 lb)	770 kg (1,694 lb)

* Maximum operating pressure and temperature are interdependent parameters and are given for general reference only. Please consult your authorized Amiad representative for the application specific parameters.

Backwash Data	
Valve drain port	80 mm (3")
Flushing time	40 seconds
Min. flow for backwash	50 m³/h (220 gpm)

Typical Installation Drawing

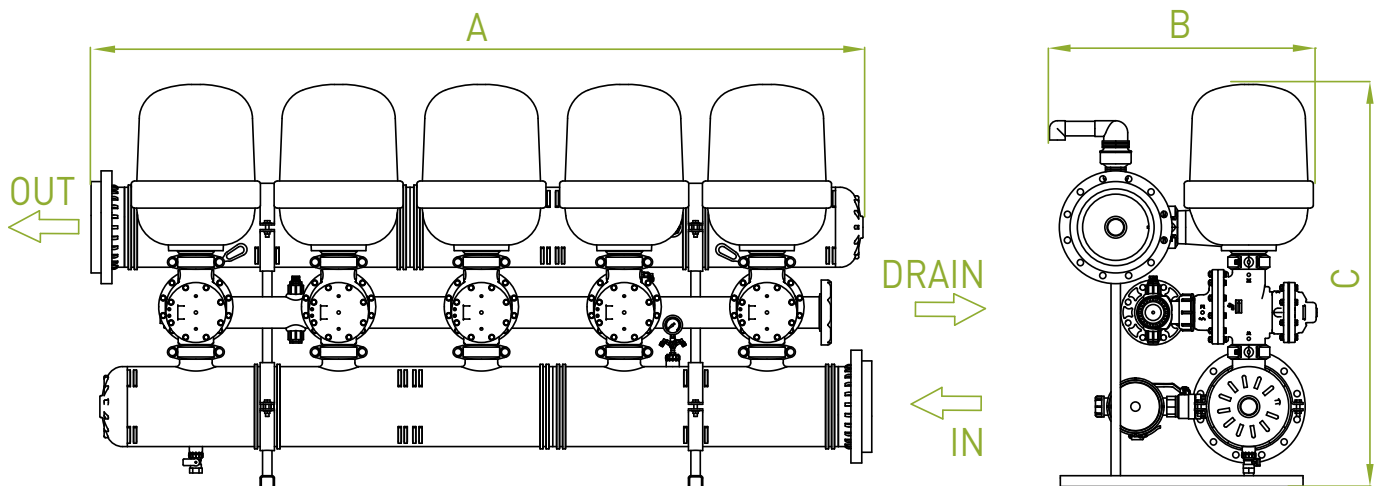

Dimensions		3 unit battery	4 unit battery	5 unit battery	6 unit battery	7 unit battery	8 unit battery
A	Length	1,734 mm (68 9/32")	2,234 mm (87 15/16")	2,734 mm (107 5/8")	3,234 mm (127 5/16")	3,734 mm (147")	4,234 mm (166 11/16")
B	Width	822 mm (32 3/8")		890 mm (35 1/32")		968 mm (38 1/8")	
C	Height	1,370 mm (53 15/16")		1,408 mm (55 7/16")		1,466 mm (57 23/32")	

Head Loss Graphs (in clean water)

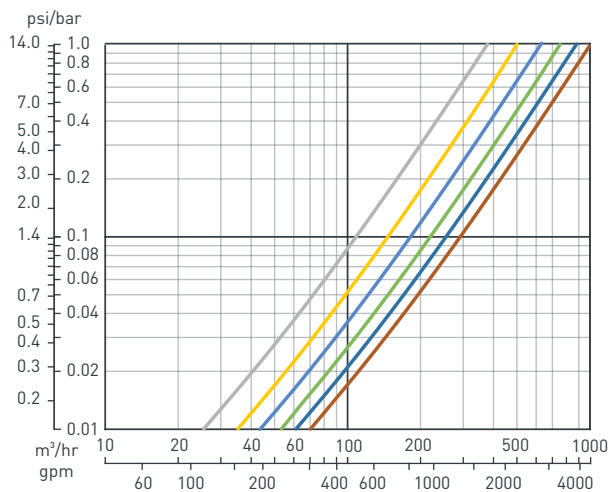

*head loss is based on a 130 micron disc

— 3 unit — 4 unit — 5 unit — 6 unit — 7 unit — 8 unit

Headquarters

Amiad Water Systems Ltd.

Web: www.amiad.com | E-mail: info@amiad.com

The Americas



USA

Amiad USA Inc.

Web: www.amiadusa.com | E-mail: infousa@amiad.com

Brazil

Amiad Sistemas de Água Ltda.

E-mail: infobrasil@amiad.com

Mexico

Amiad México SA DE CV,

Web: www.amiad.es | E-mail: infomexico@amiad.com

Irrigation office: E-mail: infomexico-irr@amiad.com

Asia



India

Amiad Filtration India Pvt Limited

Web: www.amiadindia.com | E-mail: info-india@amiad.com

China

Amiad China (Yixing Taixing Environtec Co., Ltd.)

Web: www.amiad.com.cn | E-mail: marketing@taixing.cc

South-East Asia

Filtration & Control Systems Pte. Ltd.

E-mail: info-singapore@amiad.com

Australia



Amiad Australia Pty Ltd.

Web: www.amiad.com.au | E-mail: sales@amiad.com

Europe



Amiad Water Systems Europe SAS

E-mail: info@amiad-europe.com

German branch office

E-mail: info@amiad.de

United Kingdom

Amiad Water Systems UK Limited

E-mail: info-uk@amiad.com

ozgjobal2b.com



www.amiad.com

910101-000566/05.2019

Copyright © 2019 Amiad Water Systems Ltd. All rights reserved. The contents of this catalogue including without limitation all information and materials, images, illustrations, designs, icons, photographs, graphical presentations, designs, literary works, data, drawings, slogans, phrases, names, trademarks, titles and any other such materials that appear in this catalogue (collectively, the "Contents") are the sole property of Amiad Water Systems Ltd. ("Amiad"). Amiad has sole and exclusive right, title and interest in the Contents, including any intellectual property rights, whether registered or not, and all know-how contained or embodied therein. You may not reproduce, publish, transmit, distribute, display, modify, create derivative works from, sell or participate in any sale of, or exploit in any way, in whole or in part, any of the Contents or the catalogue. Any use of the catalogue or the Contents, other than for personal use, requires the advanced written permission of Amiad.