

## 2" Spin Klin™

Automatic disc filtration system for low to medium flow rates in a compact footprint



inlet/outlet

**80 - 150 mm**  
**(3" - 6")**

flow rate

**10 - 120 m<sup>3</sup>/h**  
**(44 - 530 gpm)**

filtration degrees

**55 - 400**  
**micron**

max. operating pressure

**10 bar**  
**(145 psi)**

### features:

- Micron-precise depth filtration of solids
- Innovative disc technology captures and retains large amounts of solids
- Long-term operation with minimal maintenance
- Easy and simple operation
- Short automatic backwash with regulated water volume for a small water footprint
- Permanently eliminates the need to replace filter media
- Compact design

## How the 2" Spin Klin™ Systems Work

### General

The Arkal 2" Spin Klin™ series are modular, all polymeric, automatic disc filters with a patented self-cleaning backwash mechanism. The 2" Spin Klin™ systems range in flow rates from 10 m<sup>3</sup>/h (44 gpm) to 90 m<sup>3</sup>/h (396 gpm) with filtration degrees ranging from 55 - 400 micron. Inlet/Outlet from 80 - 150 mm (3" - 6") diameter.

### The Filtration Process

The discs are stacked on the Spin Klin™ spine and assembled according to pre-determined water filtration requirements. During filtration, the discs are compressed by means of a pre-loaded spring and differential pressure, forcing the water to pass through the grooved disc surface, thus trapping the solids.

### The Backwash Process

Activated by a pre-determined time command or differential pressure, the system enters backwash mode. The inlet valve port shuts as the drain valve port opens. During the backwash process, pressure is released and the spine's piston elevates, releasing the compression on the discs. Tangential jets of filtered water are then forced through the nozzles positioned along the spine. At this stage the discs spin freely, loosening the trapped solids which are then flushed out. During the flushing cycle each filter pod is backwashed sequentially, while the other pods continue to supply filtered water downstream. When a pod begins the backwash cycle, the system valves automatically reverse the flow in the pod, allowing filtered downstream pressurized water to backwash the filter.



Construction materials	
Filter Housing & Lid	RPA (Reinforce Polyamide) or RPP (Reinforce Polypropylene)
Disc elements	PP (Polypropylene) or PA (Polyamide)
Backwash valves	RPA (Reinforce Polyamide) or RPP (Reinforce Polypropylene)
Manifolds	PP (Polypropylene)
Seals	NBR or EPDM, (Viton optional)
Control Tubing	PE or PA

### Disc material type availability according to filtration degree:

Color Code	Gray	Purple	Green	Brown	Black	Red	Yellow	Blue
Micron	20	40	55	70	100	130	200	400
PP Disc PA (Nylon) Disc	PP, PA	PP	PP, PA	PP, PA	PP, PA	PP, PA	PP, PA	PP

Filter Type		2 unit battery	3 unit battery	4 unit battery
<b>General Data</b>				
Max. working pressure*		10 bar (145 psi)		
Min. backwash pressure		2.8 bar (40.6 psi)		
Maximum recommended flow rate	130µ	30 m <sup>3</sup> /h (132 gpm)	45 m <sup>3</sup> /h (198 gpm)	60 m <sup>3</sup> /h (264 gpm)
Filtration volume		2,296 cm <sup>3</sup> (140 in <sup>3</sup> )	3,444 cm <sup>3</sup> (210 in <sup>3</sup> )	4,592 cm <sup>3</sup> (280 in <sup>3</sup> )
Filtration area		1,760 cm <sup>2</sup> (272 in <sup>2</sup> )	2,640 cm <sup>2</sup> (409 in <sup>2</sup> )	3,520 cm <sup>2</sup> (546 in <sup>2</sup> )
Inlet/Outlet diameter		80 mm (3"), 100 mm (4")	100 mm (4")	
Max. working temperature*		60°C (140°F)		
Dry weight standard		27 kg (59.5 lb)	38 kg (83.7 lb)	49 kg (108 lb)

\* Maximum operating pressure and temperature are interdependent parameters and are given for general reference only. Please consult your authorized Amiad representative for the application specific parameters.

<b>Backwash Data</b>	
Valve drain port	50 mm (2")
Flushing time	20 seconds
Min. flow for backwash	10 m <sup>3</sup> /h (44 gpm)

### Typical Installation Drawing

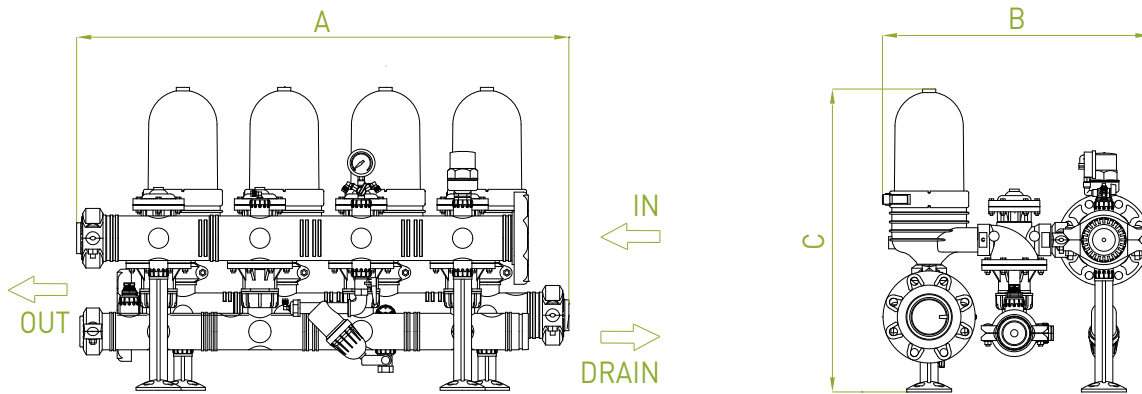

Dimensions		2 unit battery	3 unit battery	4 unit battery
A	Length	706 mm (28")	964 mm (38")	1,214 mm (48")
B	Width		660 mm (26")	
C	Height		747 mm (30")	

### Head Loss Graphs (in clean water)

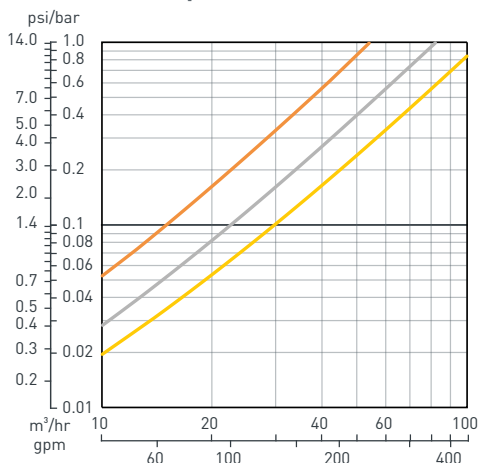

\*head loss is based on a 130 micron disc

— 2 unit — 3 unit — 4 unit

## Headquarters

**Amiad Water Systems Ltd.**

Web: [www.amiad.com](http://www.amiad.com) | E-mail: [info@amiad.com](mailto:info@amiad.com)

## The Americas



### USA

**Amiad USA Inc.**

Web: [www.amiadusa.com](http://www.amiadusa.com) | E-mail: [infousa@amiad.com](mailto:infousa@amiad.com)

### Brazil

**Amiad Sistemas de Água Ltda.**

E-mail: [infobrasil@amiad.com](mailto:infobrasil@amiad.com)

### Mexico

**Amiad México SA DE CV,**

Web: [www.amiad.es](http://www.amiad.es) | E-mail: [infomexico@amiad.com](mailto:infomexico@amiad.com)

**Irrigation office:** E-mail: [infomexico-irr@amiad.com](mailto:infomexico-irr@amiad.com)

## Asia



### India

**Amiad Filtration India Pvt Limited**

Web: [www.amiadindia.com](http://www.amiadindia.com) | E-mail: [info-india@amiad.com](mailto:info-india@amiad.com)

### China

**Amiad China (Yixing Taixing Environtec Co., Ltd.)**

Web: [www.amiad.com.cn](http://www.amiad.com.cn) | E-mail: [marketing@taixing.cc](mailto:marketing@taixing.cc)

### South-East Asia

**Filtration & Control Systems Pte. Ltd.**

E-mail: [info-singapore@amiad.com](mailto:info-singapore@amiad.com)

## Australia



**Amiad Australia Pty Ltd.**

Web: [www.amiad.com.au](http://www.amiad.com.au) | E-mail: [sales@amiad.com](mailto:sales@amiad.com)

## Europe



**Amiad Water Systems Europe SAS**

E-mail: [info@amiad-europe.com](mailto:info@amiad-europe.com)

### German branch office

E-mail: [info@amiad.de](mailto:info@amiad.de)

### United Kingdom

**Amiad Water Systems UK Limited**

E-mail: [info-uk@amiad.com](mailto:info-uk@amiad.com)



Contact us:

[Chainaris Phuket Engineering Co., Ltd.](#)

63/13 Moo.2, T.Vichit, A.Muang Phuket 83000

Tel: 076-513100-3 Fax: 076-513105

Line: [@chainaris](#), [@chainarishop](#)



[www.amiad.com](http://www.amiad.com)

910101-000560/05.2019

Copyright © 2019 Amiad Water Systems Ltd. All rights reserved. The contents of this catalogue including without limitation all information and materials, images, illustrations, designs, icons, photographs, graphical presentations, designs, literary works, data, drawings, slogans, phrases, names, trademarks, titles and any other such materials that appear in this catalogue (collectively, the "Contents") are the sole property of Amiad Water Systems Ltd. ("Amiad"). Amiad has sole and exclusive right, title and interest in the Contents, including any intellectual property rights, whether registered or not, and all know-how contained or embodied therein. You may not reproduce, publish, transmit, distribute, display, modify, create derivative works from, sell or participate in any sale of, or exploit in any way, in whole or in part, any of the Contents or the catalogue. Any use of the catalogue or the Contents, other than for personal use, requires the advanced written permission of Amiad.