



# Submersible Sewage Pumps **Vortex Impeller**

## UT/UTZ

## Compact Type Cast Iron Pumps with No Unnecessary Frills

### Economic Model

The UT/UTZ-series is economic model of the U-series, vortex pump. It is designed for a wide range of applications.

### Large Diameter Passage

The pump has a large diameter passage that makes it ideal for liquid containing various solid matters.

### Automatic Operation

The pump employs a float switch for automatic operation to prevent dry running and lower power consumption.



# NEW



### Applications

- Transferring wastewater between the tanks at small-scale treatment facility
- Draining sewage from factory, residence, hotel, restaurant, etc.
- Pumping rainwater and springwater at a place where solid matters are likely to run into the water

# Submersible Sewage Pumps

# Vortex UT/UTZ

## ■ Features

### Anti-wicking Cable Entry

An anti-wicking block is provided at the cable entry section of the motor chamber. Even if the cable jacket becomes damaged or the tip of the cable is accidentally immersed in water, this device prevents water from traveling into the motor chamber through capillary action.

### Motor Protector

A built-in thermal motor protection device reacts to the heat caused by overcurrent or run-dry conditions. It not only cuts off the motor circuit automatically but also resets by itself. When the motor cools down to a safe operating temperature, the motor restarts.

### Dual Inside Mechanical Seal

The dual inside mechanical seal (dual face mechanical seal located in an oil bath) is incorporated in all pumps. As both upper and lower sealing faces are lubricated by the oil only, it ensures a longer life of the product and a stable sealing effect.

### Oil Lifter (Patented)

The Oil Lifter is a lubricating device that forcibly lubricates the mechanical seal. It further stabilizes the functions of the mechanical seal and extends the life expectancy of the seal and also the inspection term.

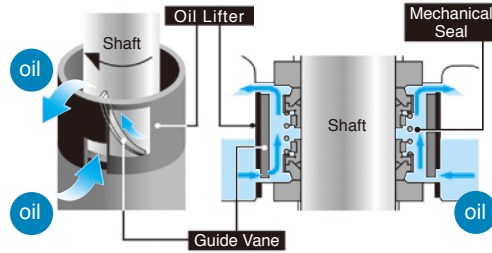

## ■ Major Components & Specifications

Discharge Bore		mm	40	50
Pumping Fluid	Type of Fluid	Sewage, Wastewater, and Liquid carrying Waste and Solid Matters		
	Fluid Temperature	0 to 40°C		
Pump	Structure	Impeller	Vortex	
		Shaft Seal	Double Mechanical Seal (with Oil Lifter)	
		Bearing	Double-shielded Ball Bearing	
	Materials	Impeller	Glass-fiber Reinforced Resin	
Casing		Gray Cast Iron		
	Shaft Seal	SiC		
Motor	Type, Pole	Dry Type Submersible Induction Motor, 2-pole		
	Insulation	Class E		
	Phase	Single-phase (suffix "S") Three-phase		
	Starting Method	Capacitor Run (single-phase only) Direct on Line		
	Protection Device (Built-in)	Circle Thermal Protector Miniature Thermal Protector (0.25 and 0.4kW of single-phase)		
	Lubricant	Turbine Oil (ISO VG32)		
	Materials	Frame	Gray Cast Iron	
Shaft		403 Stainless Steel		
Cable		PVC		
Discharge Connection		Screwed Flange		

## ■ Performance Curves

Standard and Automatic models have the identical performance.

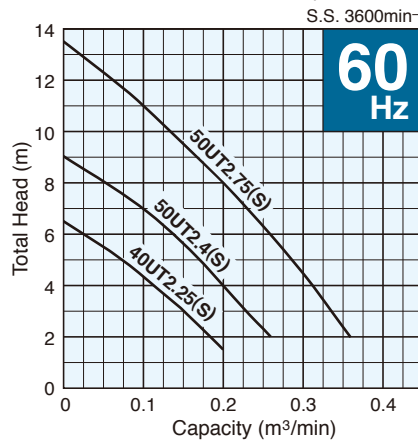
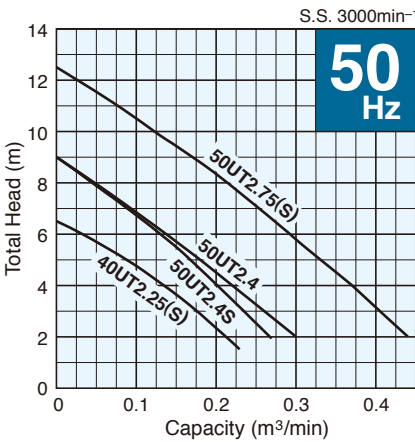

## ■ Dimensions

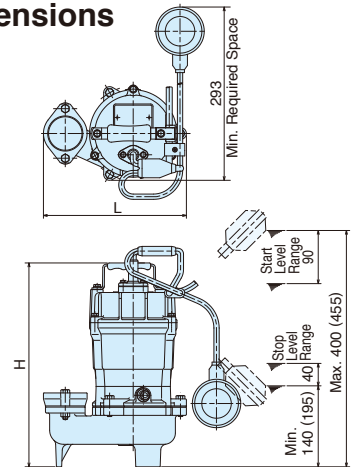

\* The figure in parentheses is for the 50UTZ2.75S.

## ■ Model Selection

Discharge Bore mm	Model		Guide Rail Fitting	Motor Output kW	Phase	Starting Method	Solids Passage mm	Dimensions L × H mm	Dry Weight kg	Cable Length m
	Standard	Automatic								
40	40UT2.25S	40UTZ2.25S	(TOK4-A)	0.25	Single	Capacitor Run	35	239 × 350	13.5	5
40	40UT2.25	—	(TOK4-A)	0.25	Three	D.O.L.	35	239 × 350	13	5
50	50UT2.4S	50UTZ2.4S	(TOK4-A)	0.4	Single	Capacitor Run	35	242 × 350	13.5	5
50	50UT2.4	—	(TOK4-A)	0.4	Three	D.O.L.	35	242 × 350	13	5
50	50UT2.75S	50UTZ2.75S	(TOK4-A)	0.75	Single	Capacitor Run	35	242 × 406	16.5	5
50	50UT2.75	—	(TOK4-A)	0.75	Three	D.O.L.	35	242 × 387	15.5	5

- For use in combination with the guide rail fitting, order the pump and the TOK4-A guide rail fitting individually.
- Weights excluding cable

We reserve the right to change the specifications and designs for improvement without prior notice.

**TSURUMI**  
**MANUFACTURING CO., LTD.**

Your Dealer

Chainaris Phuket Engineering Co., Ltd.

63/13 Moo.2, T.Vichit, A.Muang Phuket 83000

Tel. 076-513100-3

Fax. 076-513105

[www.chainaris.co.th](http://www.chainaris.co.th)

