



**Horizontal Stainless Steel
Centrifugal Pumps**

THM/THMS TSM/TSMS



THM/THMS-series

Horizontal Stainless Steel Multistage Centrifugal Pump

Tsurumi THM/THMS-series is a horizontal multistage centrifugal pump designed for handling freshwater. Major pump components are made of 304 stainless steel, which make it lightweight and enable to protect the pumped liquid from contamination caused by rust.

Applications

- Irrigating Agricultural Farm
- Supplying and Distributing Industrial Water
- Circulating Cold and Warm Water

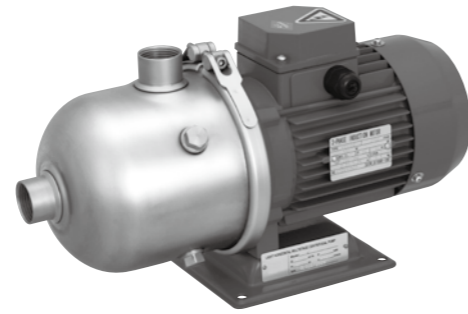

Model Number Designation

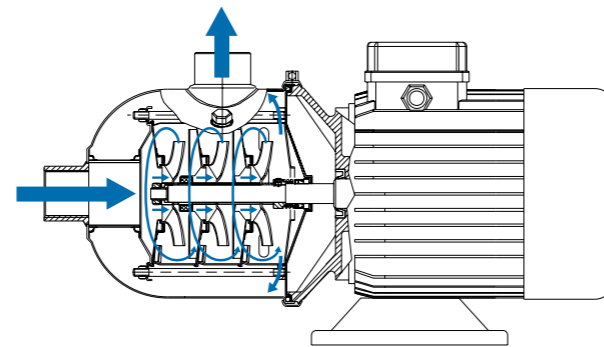
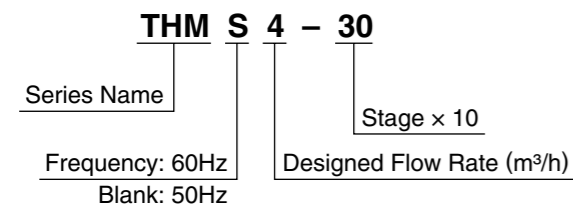

Water flow in the main unit

Major Standard Specifications

Inlet x Outlet Bore		mm	25 x 25	32 x 25	50 x 50
Liquid	Type	Freshwater			
	Temperature	-15 to 70°C			
Pump	Structure	Impeller	Closed		
		Shaft Seal	Mechanical Seal		
	Materials	Impeller	304 Stainless Steel		
		Casing	304 Stainless Steel		
Shaft Seal	Silicon Carbide				
Motor	Type, Pole		TEFC, 2-pole		
	Motor Enclosure		IP55		
	Insulation		Class F		
	Phase		Single-phase (up to 2.4kW) Three-phase		
	Starting Method	Single-phase	Capacitor Start (0.55kW and below) Capacitor Start + Capacitor Run		
		Three-phase	D.O.L.		
Materials	Frame	Aluminium Alloy Die-casting			
	Shaft	304 Stainless Steel			
Inlet & Outlet Connection		Screw			

Performance Range

ISO9906 Annex A

S.S. 3000min⁻¹

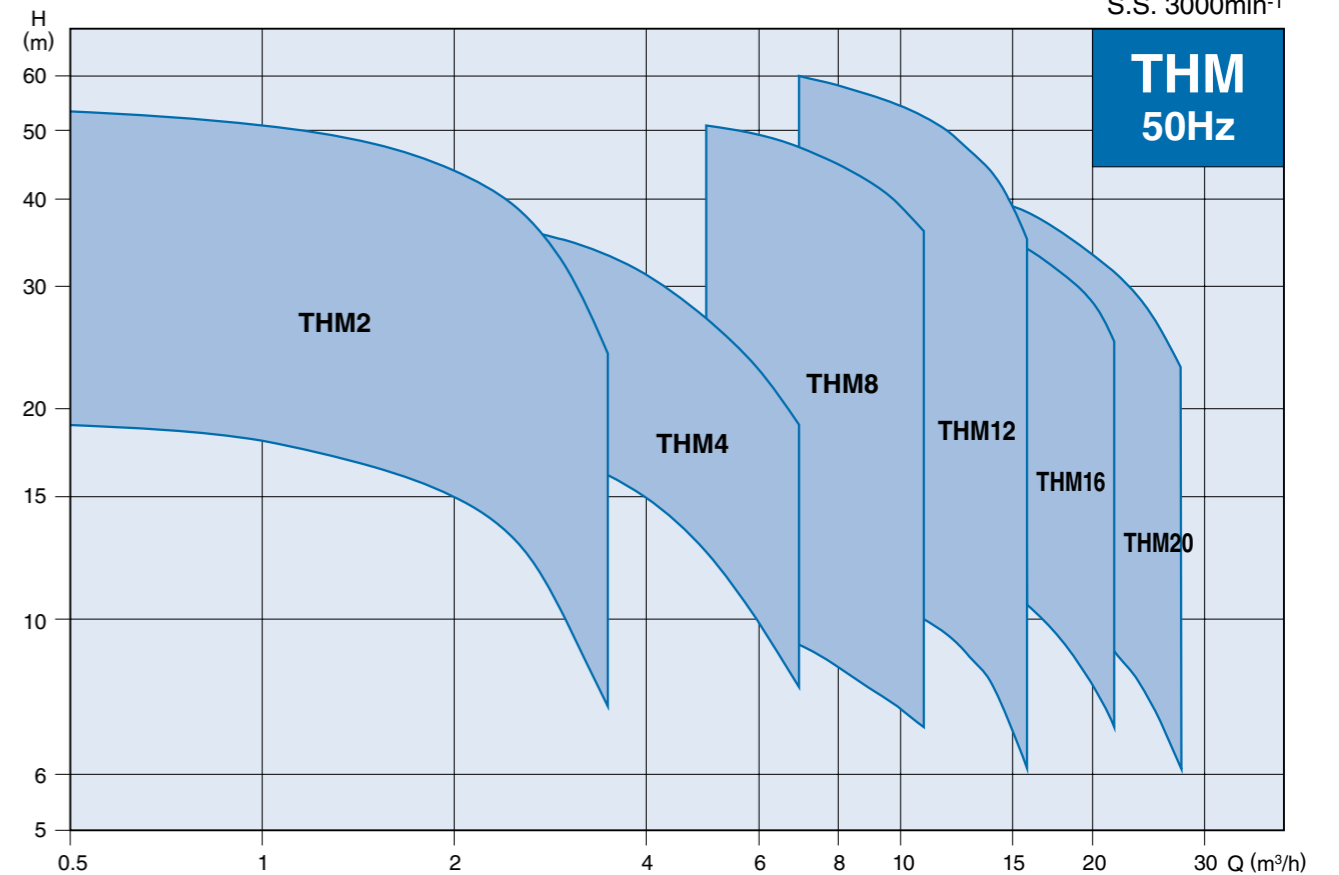

S.S. 3600min⁻¹

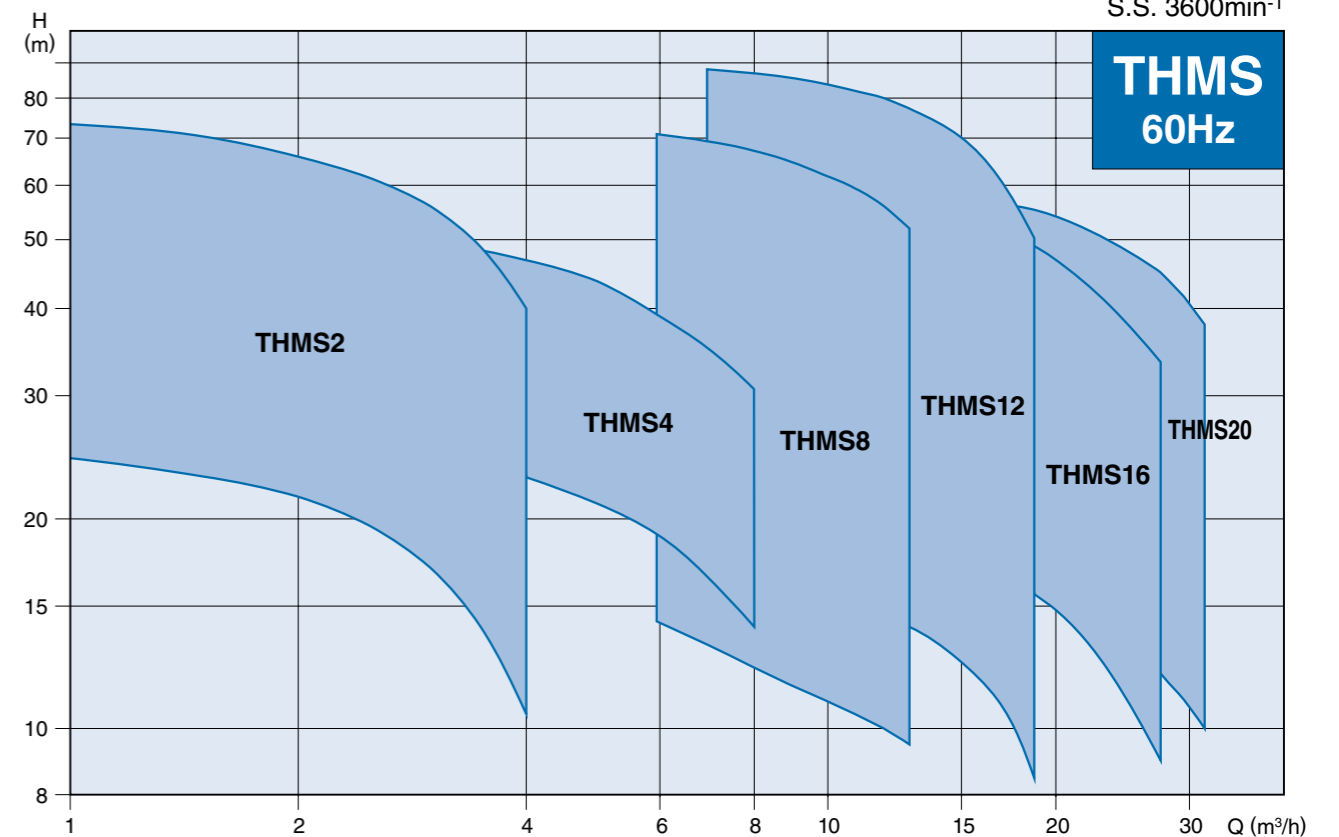

Cross-Section

THM / THMS 2 · 4

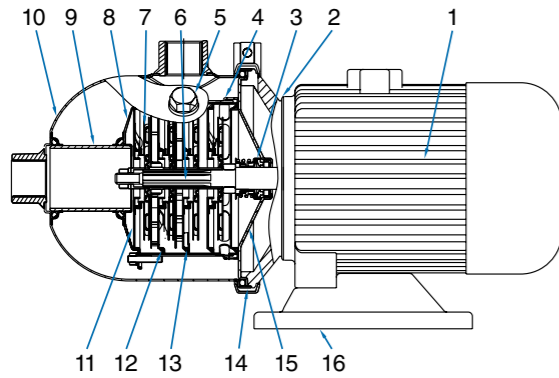

THM / THMS 8 · 12 · 16 · 20

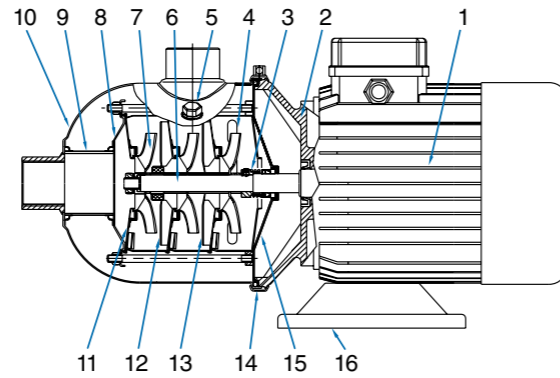

No.	Description	Material
1	Motor	
2	Motor End Cover	Aluminium Alloy Die-casting
3	Mechanical Seal	Silicon Carbide
4	Discharge Diffuser	304 Stainless Steel
5	Air Bent Plug	304 Stainless Steel
6	Shaft	304 Stainless Steel
7	Impeller	304 Stainless Steel
8	Clamp Plate	304 Stainless Steel
9	Connection Pipe	304 Stainless Steel
10	Inlet & Outlet Chamber	304 Stainless Steel
11	Inducer	304 Stainless Steel
12	Support Diffuser	304 Stainless Steel
13	Diffuser	304 Stainless Steel
14	Span Band	304 Stainless Steel
15	Seal Plate	304 Stainless Steel
16	Base Plate	Carbon Steel

Performance Data

THM2

Performance Curves

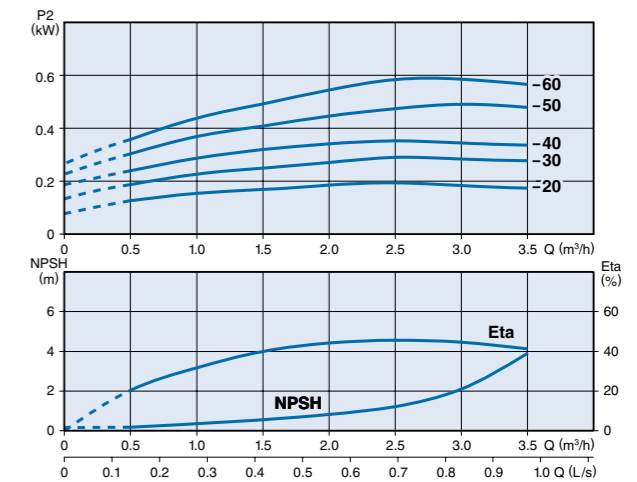
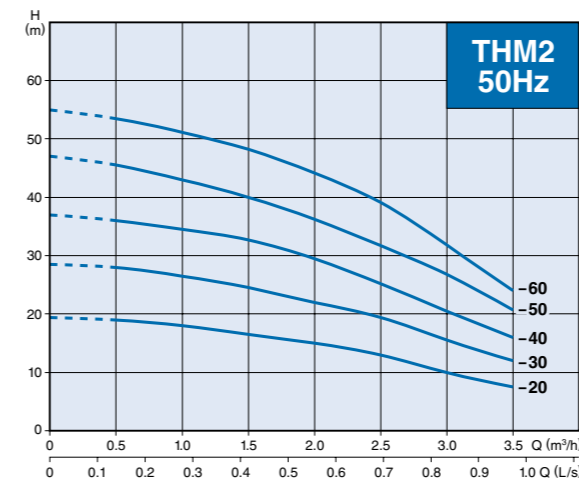

Performance Table

Model	Inlet x Outlet Bore (mm)	Motor Output (kW)	Q (m³/h)	0.5	1.0	1.5	2.0	2.5	3.0	3.5
THM2-20	25 x 25	0.37	H (m)	19	18	16.5	15	13	10	7.5
THM2-30	25 x 25	0.55		28	26.5	24.5	22	19	15.5	12
THM2-40	25 x 25	0.55		36	34.5	33	29	25	20.5	16
THM2-50	25 x 25	0.55		45.5	43	40	36	31.5	26.5	20.5
THM2-60	25 x 25	0.75		53.5	51	48	44	39	32	24

Performance Data

THMS2

Performance Curves

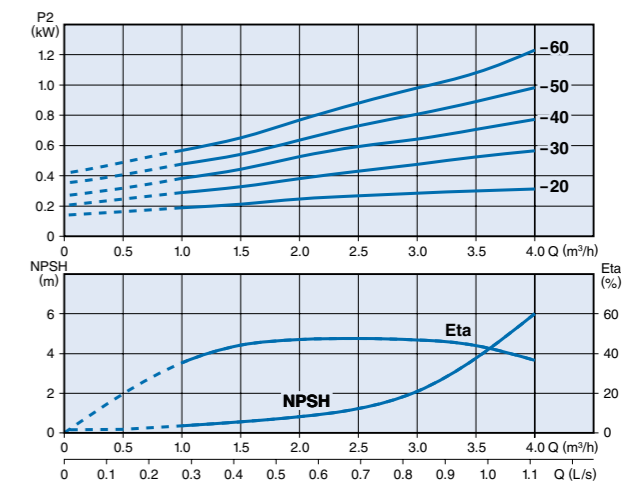
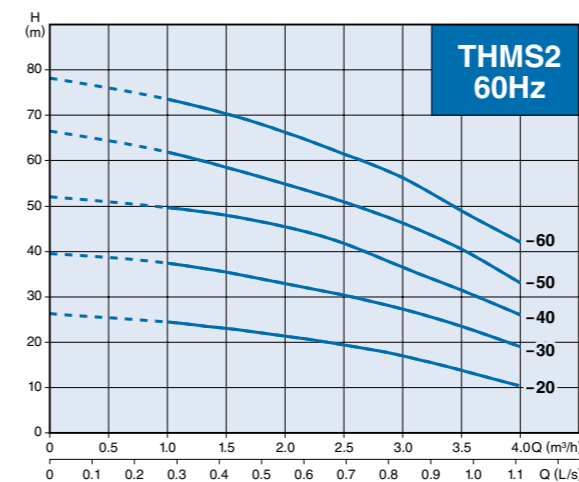

Performance Table

Model	Inlet x Outlet Bore (mm)	Motor Output (kW)	Q (m³/h)	1.0	1.5	2.0	2.5	3.0	3.5	4.0
THMS2-20	25 x 25	0.55	H (m)	24.5	23	21.5	19.5	17	14	10.5
THMS2-30	25 x 25	0.75		37.5	35.5	33	30.5	27.5	23.5	19
THMS2-40	25 x 25	1.1		49.5	48	45.5	42	36	32	26
THMS2-50	25 x 25	1.1		62	58.5	55	51	46	40.5	33
THMS2-60	25 x 25	1.5		73.5	70.5	66	61.5	56	49	40

THM4

Performance Curves

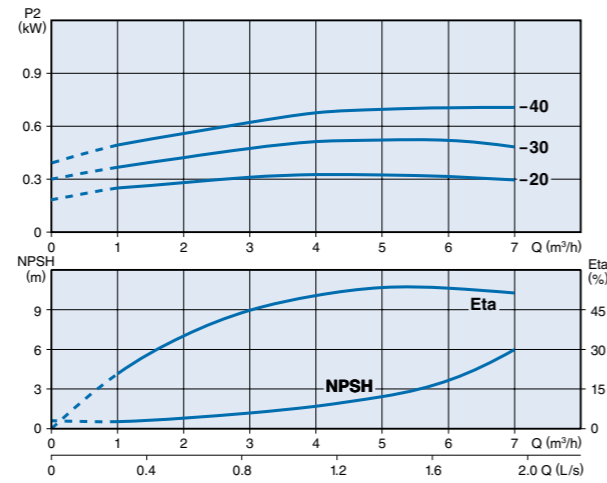
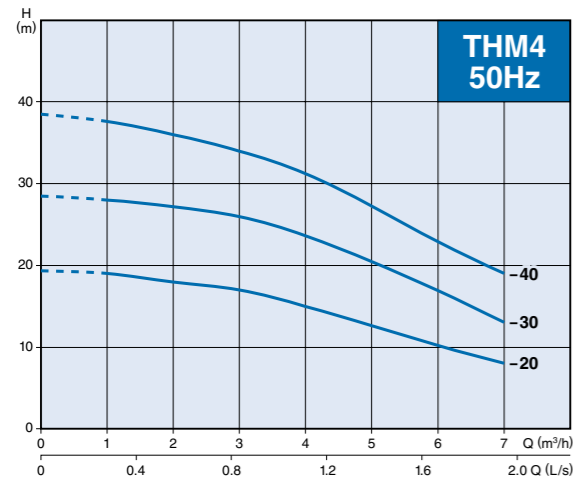

Performance Table

Model	Inlet x Outlet Bore (mm)	Motor Output (kW)	Q (m³/h)	1	2	3	4	5	6	7
THM4-20	32 x 25	0.55	H (m)	19	18	17	15	12.5	10	8
THM4-30	32 x 25	0.75		28	27	26	23.5	20.5	17	13
THM4-40	32 x 25	0.75		37.5	36	34	31	27	23	19

THMS4

Performance Curves

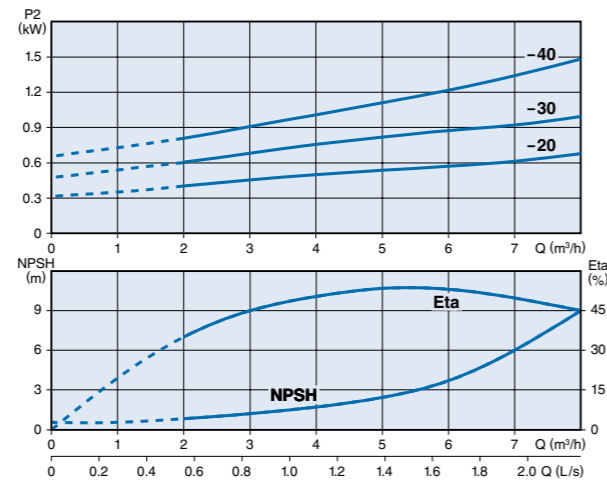
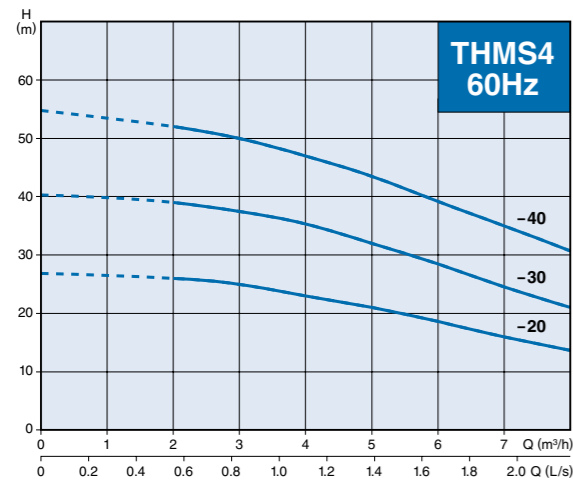

Performance Table

Model	Inlet x Outlet Bore (mm)	Motor Output (kW)	Q (m³/h)	2	3	4	5	6	7	8
THMS4-20	32 x 25	0.75	H (m)	26	25	23	21	19	16	14
THMS4-30	32 x 25	1.1		39	37.5	36	32	28	24	21
THMS4-40	32 x 25	1.5		52	50	47	43.5	38.5	35	31

THM8

Performance Curves

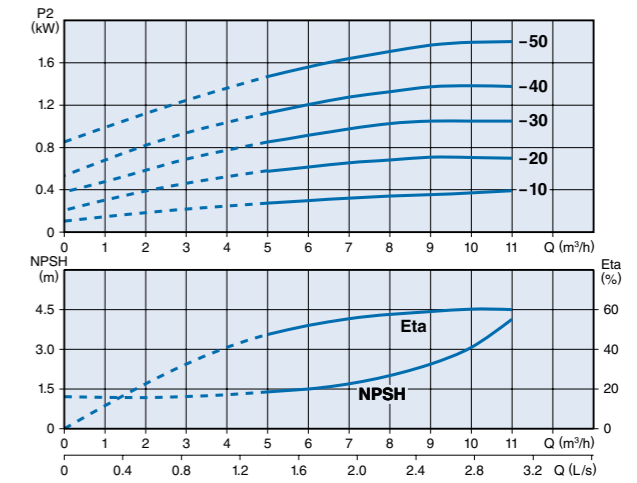
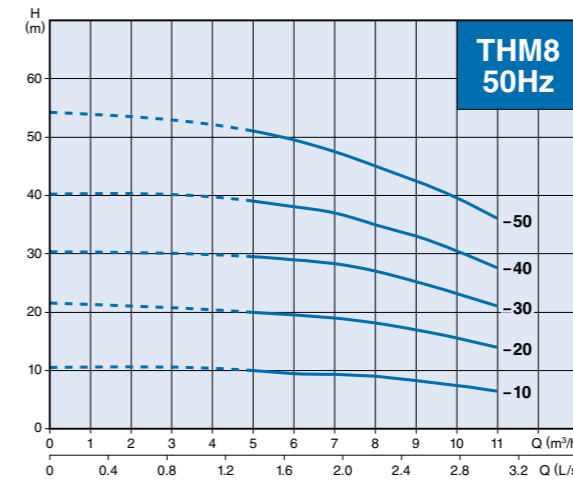

Performance Table

Model	Inlet x Outlet Bore (mm)	Motor Output (kW)	Q (m³/h)	5	6	7	8	9	10	11
THM8-10	50 x 50	0.75	H (m)	10	9.5	9.3	9	8	7.5	7
THM8-20	50 x 50	0.75		20	19.5	19	18	17	15.5	14
THM8-30	50 x 50	1.1		29.5	29	28	27	25	23	21
THM8-40	50 x 50	1.5		39	38	37	35	33	30.5	27.5
THM8-50	50 x 50	2.2		51	49.5	47.5	45	42.5	39.5	36

THMS8

Performance Curves

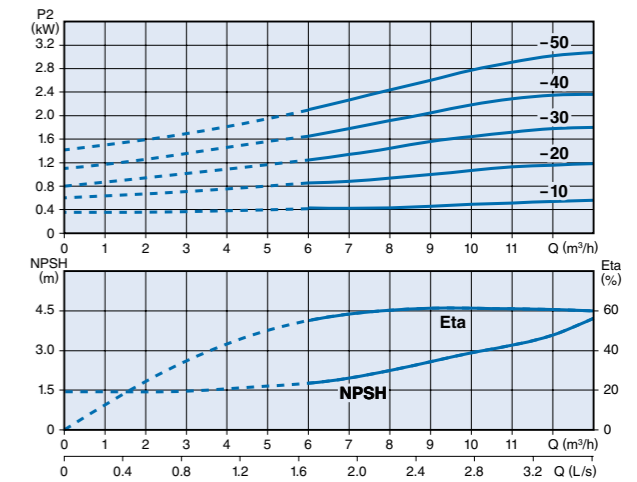
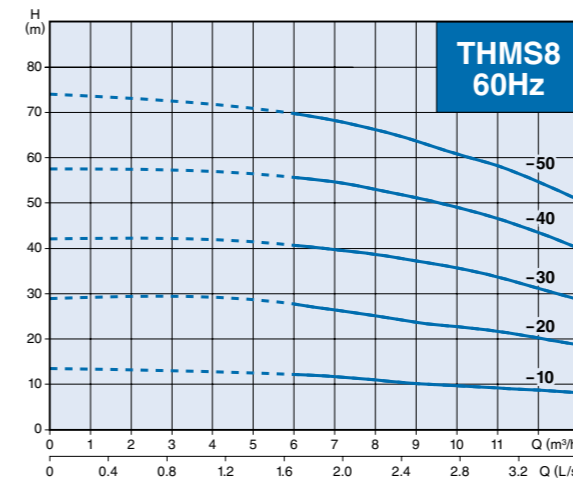

Performance Table

Model	Inlet x Outlet Bore (mm)	Motor Output (kW)	Q (m³/h)	6	7	8	9	10	11	12	13
THMS8-10	50 x 50	0.75	H (m)	14.5	13	12	11.5	11	10.5	10	9.5
THMS8-20	50 x 50	1.5		29	27	26	25	24	23	21.5	20
THMS8-30	50 x 50	2.2		42	41	40	39	37	35	33	30
THMS8-40	50 x 50	3		55.5	54.5	53	51	49	46.5	43.5	40
THMS8-50	50 x 50	3		71	69.5	67.5	65	63	59	56	52

THM12

Performance Curves

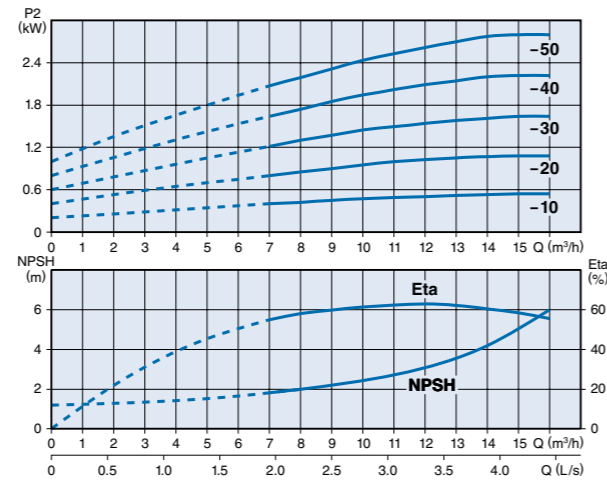
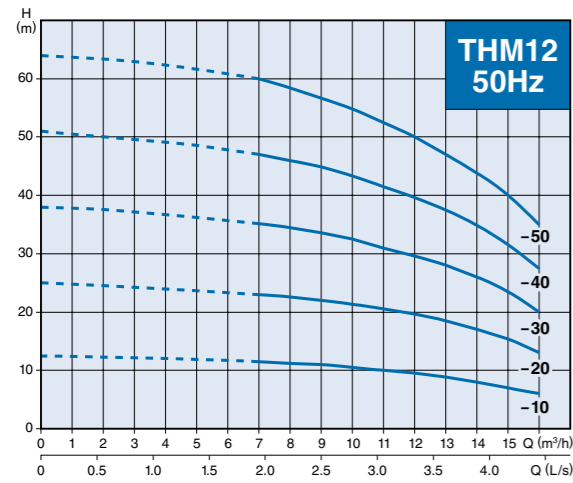

Performance Table

Model	Inlet x Outlet Bore (mm)	Motor Output (kW)	Q (m³/h)	7	8	9	10	11	12	13	14	15	16
THM12-10	50 x 50	0.75	H (m)	11.5	11.2	11	10.5	10	9.5	9	8	7	6
THM12-20	50 x 50	1.2		23	22.5	22	21.5	20.5	19.5	18.5	17	15.5	13
THM12-30	50 x 50	1.8		35	34.5	33.5	32.5	31	29.5	28	26	23.5	20
THM12-40	50 x 50	2.4		47	46	45	43.5	41.5	39.5	37.5	35	31.5	27.5
THM12-50	50 x 50	3		60	58	56.5	55	52.5	50	47	44	40	35

THMS12

Performance Curves

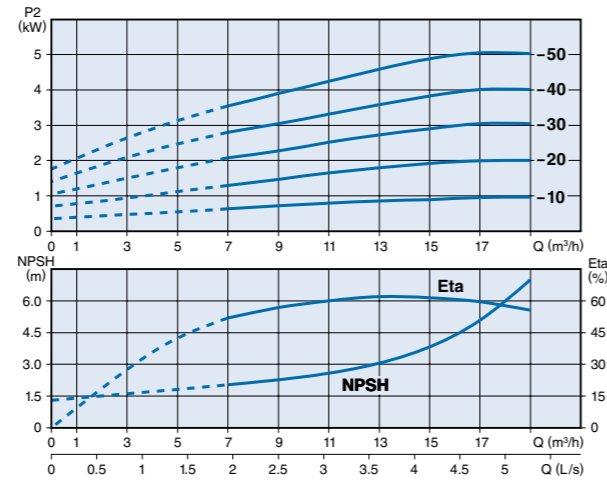
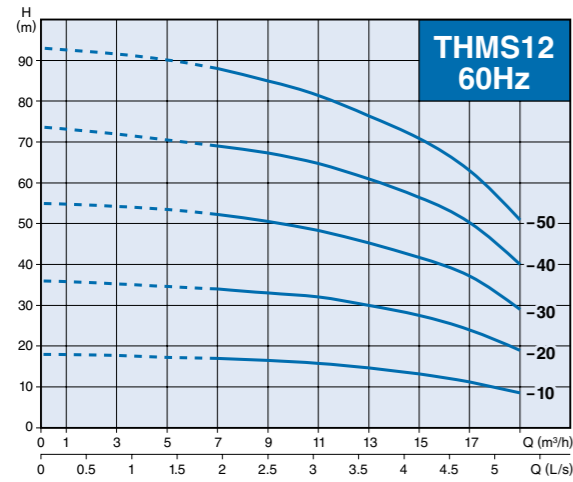

Performance Table

Model	Inlet x Outlet Bore (mm)	Motor Output (kW)	Q (m³/h)	7	9	11	12	13	15	17	19
THMS12-10	50 x 50	1.1	H (m)	17	16	15	14.5	14	12.5	11	8.5
THMS12-20	50 x 50	2.2		34	33	32	31	30	27	24.5	19
THMS12-30	50 x 50	3		52.5	50	48.5	47	45	41.5	37.5	29
THMS12-40	50 x 50	4		69	67.5	65	63	60.5	55	49.5	40
THMS12-50	50 x 50	5.5		88	85	82	80	76	70	62	50.5

THM16

Performance Curves

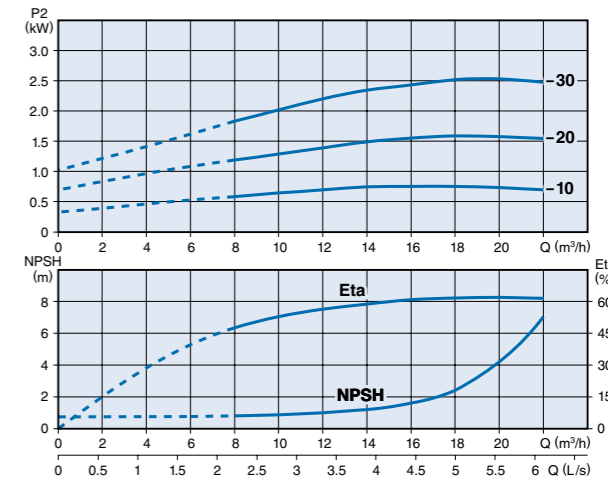
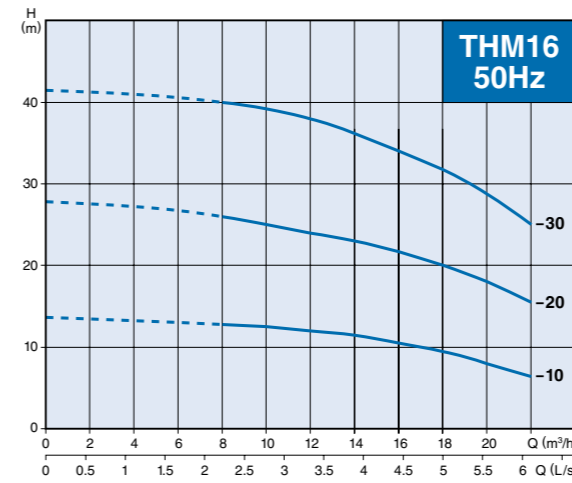

Performance Table

Model	Inlet x Outlet Bore (mm)	Motor Output (kW)	Q (m³/h)	8	10	12	14	16	18	20	22
THM16-10	50 x 50	1.1	H (m)	12.8	12.5	12	11.5	10.5	9.5	8	7
THM16-20	50 x 50	2.2		26	25	24	23	21.7	20	18	15.5
THM16-30	50 x 50	3		40	39	38	36	34	31.5	29	25

THMS16

Performance Curves

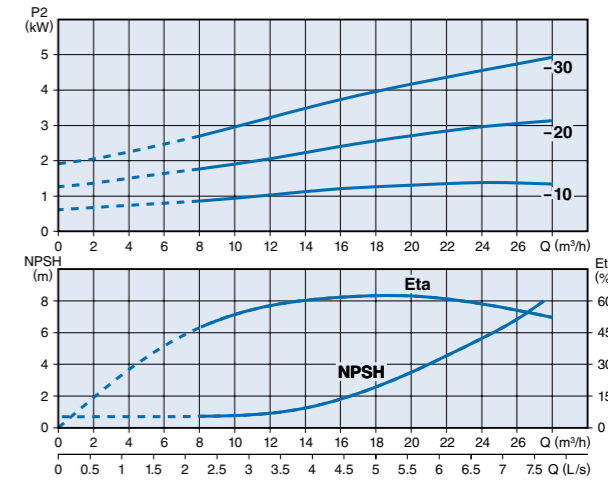
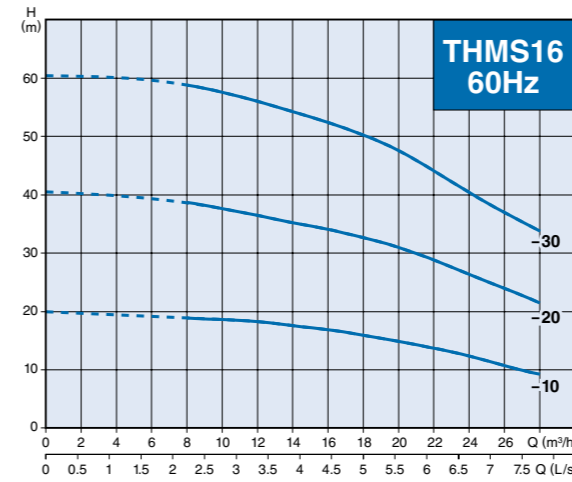

Performance Table

Model	Inlet x Outlet Bore (mm)	Motor Output (kW)	Q (m³/h)	8	12	16	20	24	28
THMS16-10	50 x 50	2.2	H (m)	19	18	17	15	12	9
THMS16-20	50 x 50	4		38.5	36.5	34	31	26	21.5
THMS16-30	50 x 50	5.5		59	56	53.5	47.5	40.3	33.5

THM20

Performance Curves

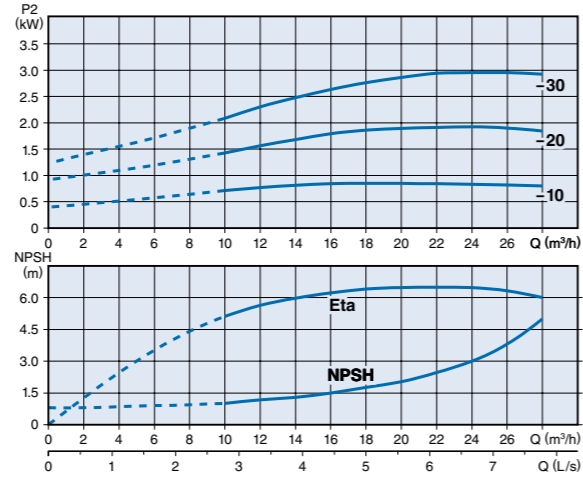
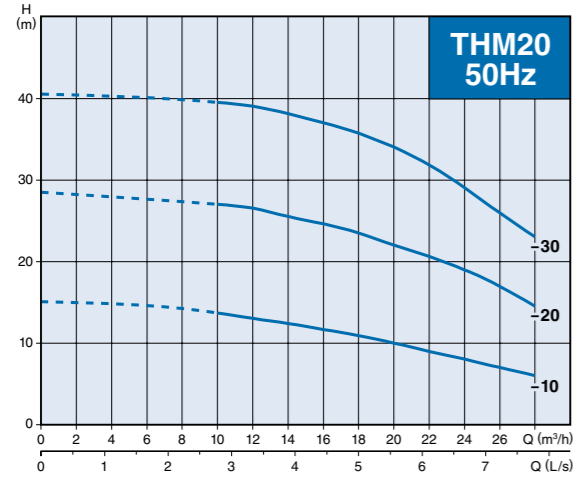

Performance Table

Model	Inlet x Outlet Bore (mm)	Motor Output (kW)	Q (m³/h)	H (m)												
				10	12	14	16	18	20	22	24	26	28			
THM20-10	50 x 50	1.1	H (m)	13.5	13	12.5	12	11	10	9	8	7	6			
THM20-20	50 x 50	2.2		27	26.5	25.5	25	23.5	22	20.5	18.5	17	14.5			
THM20-30	50 x 50	4		39.5	39	38	37.5	35.5	34	31.5	29	26	23			

THMS20

Performance Curves

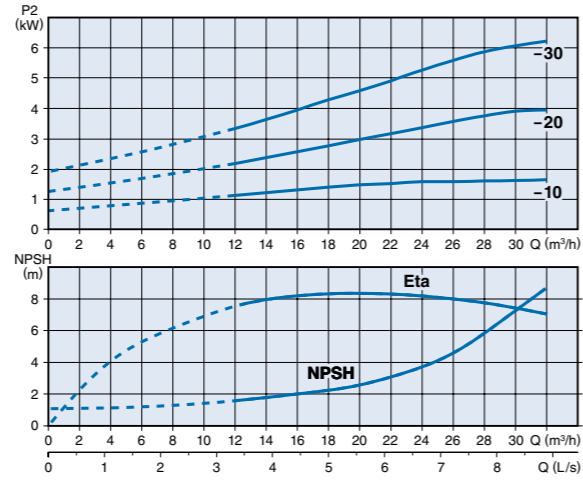
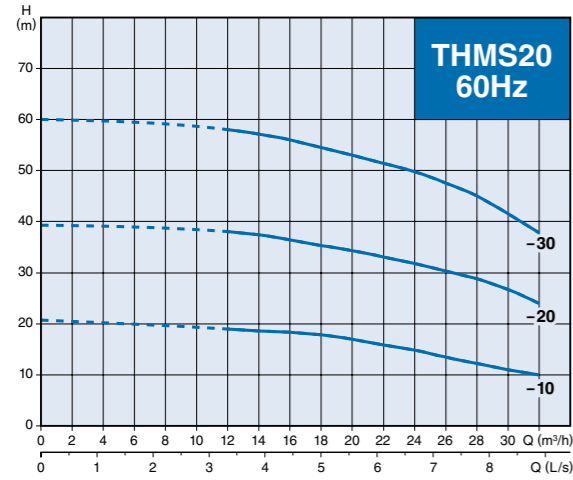

Performance Table

Model	Inlet x Outlet Bore (mm)	Motor Output (kW)	Q (m³/h)	H (m)												
				12	14	16	18	20	22	24	26	28	30	32		
THMS20-10	50 x 50	2.2	H (m)	19	18.5	18	17.5	17	16	15	13.5	12	11	10		
THMS20-20	50 x 50	4		38	37	36	35	34	33	32	30.5	29	26.5	24		
THMS20-30	50 x 50	5.5		58	57	56	55	53	51.4	50	47.5	45	41.6	38		

Dimensions

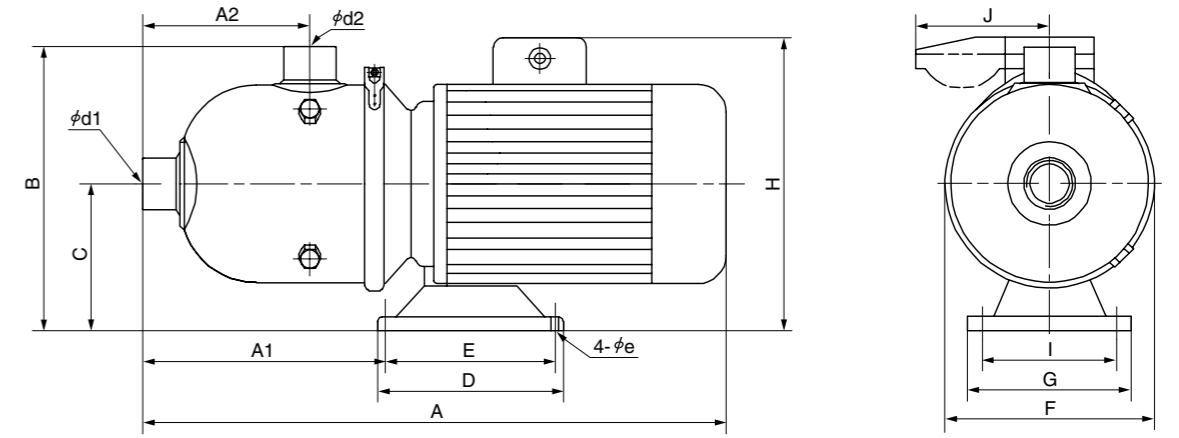

Unit: mm

Model	d1	d2	A	A1	A2	H		B	C	D	e	E	F	G	I	J		Dry Weight (kg)
						Phase										Single	Three	
						Single	Three											
THM2-20	25	25	400	160	120	230	215	215	110	160	9	138	165	130	108	96	—	13
THM2-30	25	25	400	160	120	230	215	215	110	160	9	138	165	130	108	96	—	13
THM2-40	25	25	400	160	120	230	215	215	110	160	9	138	165	130	108	96	—	13
THM2-50	25	25	400	160	120	230	215	215	110	160	9	138	165	130	108	96	—	13
THM2-60	25	25	445	160	120	245	225	215	110	160	9	138	165	130	108	100	—	15
THM4-20	32	25	400	160	120	230	215	215	110	160	9	138	165	130	108	96	—	12
THM4-30	32	25	445	160	120	245	225	215	110	160	9	138	165	130	108	100	—	15
THM4-40	32	25	445	160	120	245	225	215	110	160	9	138	165	130	108	100	—	15
THM8-10	50	50	560	280	178	265	230	268	118	160	9	138	230	130	108	100	—	20
THM8-20	50	50	560	280	178	265	230	268	118	160	9	138	230	130	108	100	—	20
THM8-30	50	50	560	280	178	265	230	268	118	160	9	138	230	130	108	100	—	25
THM8-40	50	50	580	280	178	270	240	268	118	160	9	138	230	130	108	100	—	25
THM8-50	50	50	580	280	178	270	240	268	118	160	9	138	230	130	108	100	—	30
THM12-10	50	50	560	280	178	265	230	268	118	160	9	138	230	130	108	100	—	20
THM12-20	50	50	560	280	178	265	230	268	118	160	9	138	230	130	108	100	—	21
THM12-30	50	50	580	280	178	270	240	268	118	160	9	138	230	130	108	100	—	25
THM12-40	50	50	580	280	178	270	240	268	118	160	9	138	230	130	108	100	—	29
THM12-50	50	50	610	270	178	—	270	276	126	160	9	138	230	130	108	—	—	34
THM16-10	50	50	560	280	178	265	230	268	118	160	9	138	230	130	108	100	—	20
THM16-20	50	50	580	280	178	270	240	268	118	160	9	138	230	130	108	100	—	27
THM16-30	50	50	610	270	178	—	270	276	126	160	9	138	230	130	108	—	—	34
THM20-10	50	50	560	280	178	265	230	268	118	160	9	138	230	130	108	100	—	21
THM20-20	50	50	580	280	178	270	240	268	118	160	9	138	230	130	108	100	—	28
THM20-30	50	50	650	360	178	—	270	270	120	170	12	140	230	230	190	—	—	42
THMS2-20	25	25	400	160	120	230	215	210	110	160	9	138	165	130	108	96	—	13
THMS2-30	25	25	420	160	120	245	220	210	110	160	9	138	165	130	108	100	—	13
THMS2-40	25	25	420	160	120	245	230	210	110	160	9	138	165	130	108	100	—	15
THMS2-50	25	25	420	160	120	245	230	210	110	160	9	138	165	130	108	100	—	15
THMS2-60	25	25	470	160	120	260	240	218	118	160	9	138	165	130	108	100	—	20
THMS4-20	32	25	420	160	120	245	230	210	110	160	9	138	165	130	108	100	—	12
THMS4-30	32	25	420	160	120	245	230	210	110	160	9	138	165	130	108	100	—	15
THMS4-40	32	25	470	160	120	260	240	228	118	160	9	138	165	130	108	100	—	20
THMS8-10	50	50	560	280	178	265	230	263	117	160	9	138	230	130	108	100	—	20
THMS8-20	50	50	580	280	178	270	230	264	118	160	9	138	230	130	108	100	—	25
THMS8-30	50	50	580	280	178	270	230	264	118	160	9	138	230	130	108	100	—	25
THMS8-40	50	50	610	280	178	—	270	274	128	160	9	138	230	130	108	—	—	30
THMS8-50	50	50	610	280	178	—	270	274	128	160	9	138	230	130	108	—	—	30
THMS12-10	50	50	560	280	178	265	230	268	118	160	9	138	230	130	108	100	—	22
THMS12-20	50	50	580	280	178	270	240	268	118	160	9	138	230	130	108	100	—	25
THMS12-30	50	50	610	270	178	—	270	276	126	160	9	138	230	130	108	—	—	32
THMS12-40	50	50	650	360	178	—	270	270	120	170	12	140	230	230	190	—	—	44
THMS12-50	50	50	670	375	178	—	305	282	132	190	12	140	230	260	216	—	—	58
THMS16-10	50	50	580	280	178	270	230	264	118	160	9	138	230	130	108	100	—	25
THMS16-20	50	50	650	360	178	—	270	270	120	170	12	140	230	230	190	—	—	43
THMS16-30	50	50	670	375	178	—	305	281	132	190	12	140	230	260	216	—	—	50
THMS20-10	50	50	580	280	178	270	240	268	118	160	9	138	230	230	108	100	—	26
THMS20-20	50	50	650	360	178	—	270	270	120	170	12	140	230	230	190	—	—	43
THMS20-30	50	50	670	375	178	—	305	280	132	190	12	140	230	260	216	—	—	56

TSM/TSMS-series

Horizontal Stainless Steel Single-stage Centrifugal Pump

Tsurumi TSM/TSMS-series is a horizontal single-stage centrifugal pump designed for handling freshwater. Major pump components are made of 304 stainless steel, which make it lightweight and enable to protect the pumped liquid from contamination caused by rust. Screwed inlet and outlet ports provide convenient connections.

Applications

- Irrigating Agricultural Farm
- Supplying and Distributing Industrial Water
- Circulating Cold and Warm Water



Model Number Designation

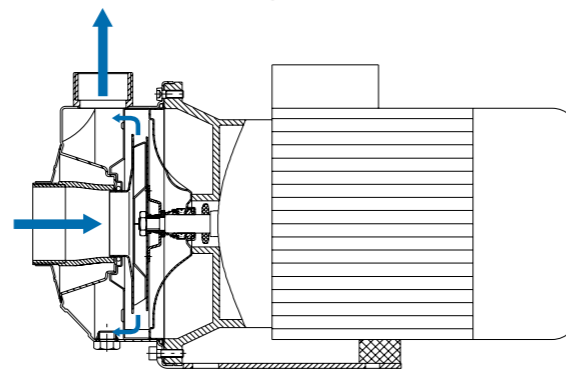
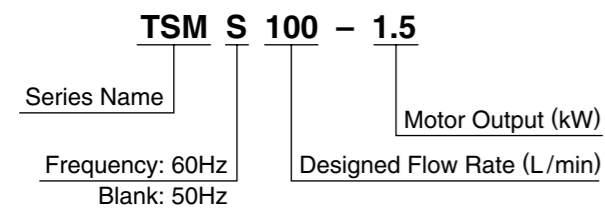

Water flow in the main unit

Major Standard Specifications

Inlet x Outlet Bore		mm	32 x 25	40 x 32	50 x 32
Liquid	Type	Freshwater			
	Temperature	-10 to 85°C			
Pump	Structure	Impeller	Closed		
		Shaft Seal	Mechanical Seal		
	Materials	Impeller	304 Stainless Steel		
		Casing	304 Stainless Steel		
Shaft Seal	Silicon Carbide				
Motor	Type, Pole	TEFC, 2-pole			
	Motor Enclosure	IP55			
	Insulation	Class F			
	Phase	Single-phase			
		Three-phase			
	Starting Method	Single-phase	Capacitor Start (0.55kW and below) Capacitor Start + Capacitor Run		
		Three-phase	D.O.L.		
Materials	Frame	Aluminium Alloy Die-casting			
	Shaft	304 Stainless Steel			
Inlet & Outlet Connection		Screw			

Performance Range

ISO9906 Annex A

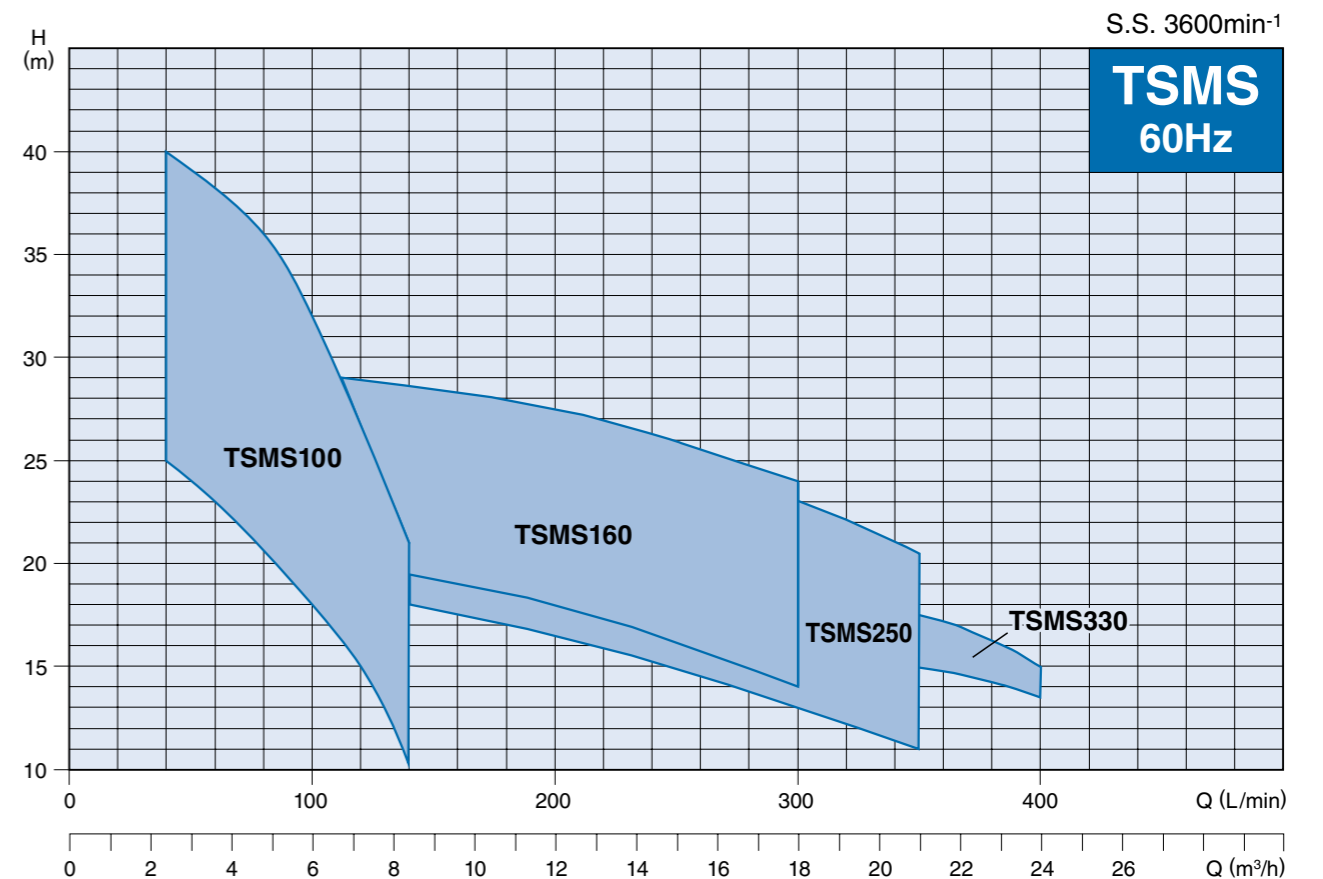
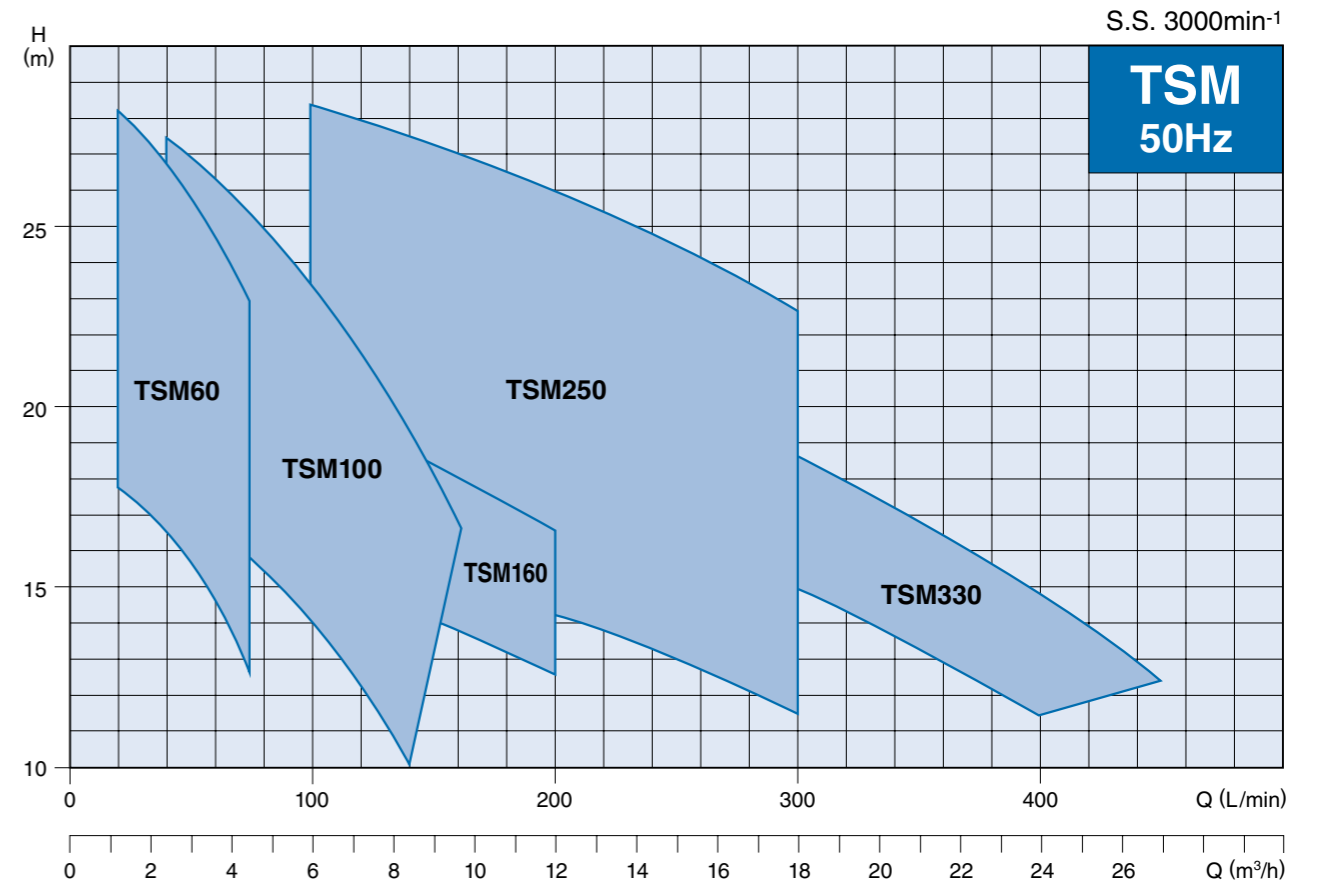

Cross-Section

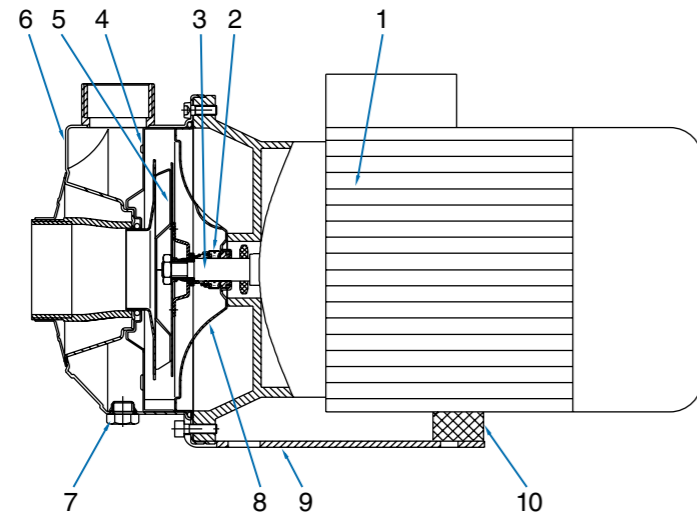

No.	Description	Material
1	Motor	
2	Mechanical Seal	Silicon Carbide
3	Shaft	304 Stainless Steel
4	Diffuser	304 Stainless Steel
5	Impeller	304 Stainless Steel
6	Inlet & Outlet Chamber	304 Stainless Steel
7	Drain Plug	304 Stainless Steel
8	Seal Plate	304 Stainless Steel
9	Base Plate	Carbon Steel
10	Support Foot	NBR

Performance Data TSM60

Performance Curves

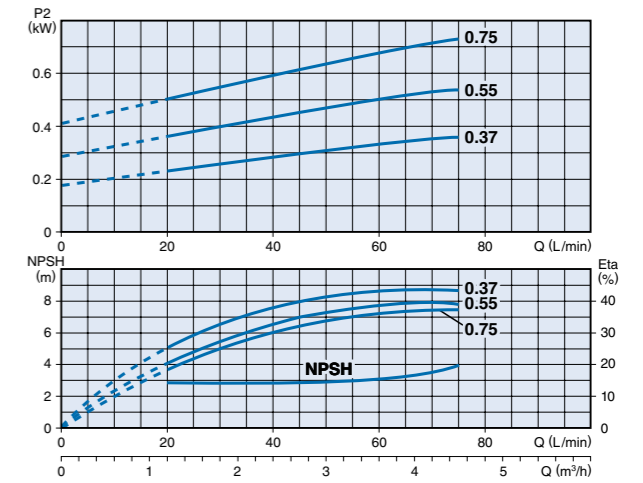
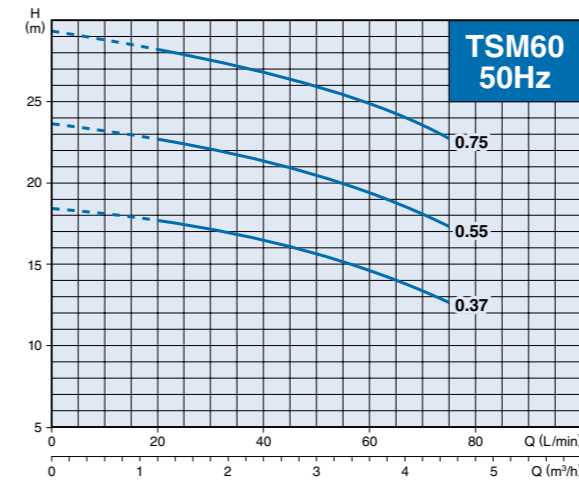

Performance Table

Model	Inlet x Outlet Bore (mm)	Motor Output (kW)	Q (L/min) Q (m³/h)	20	40	60	75
				H (m)			
TSM60-0.37	32 x 25	0.37		17.7	16.4	14.6	12.7
TSM60-0.55	32 x 25	0.55		22.7	21.3	19.5	17.3
TSM60-0.75	32 x 25	0.75		28.2	26.8	25	22.8

TSM100

Performance Curves

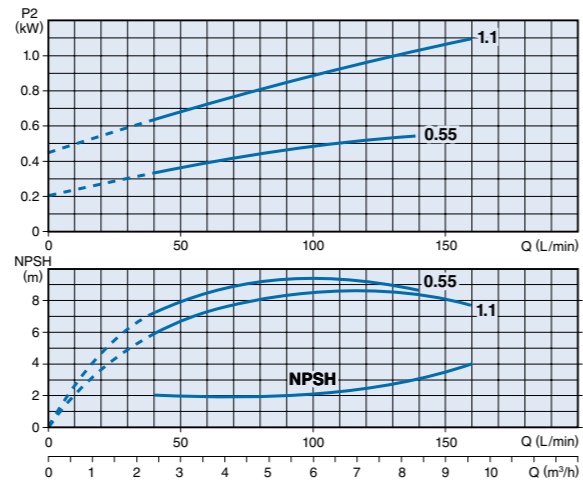
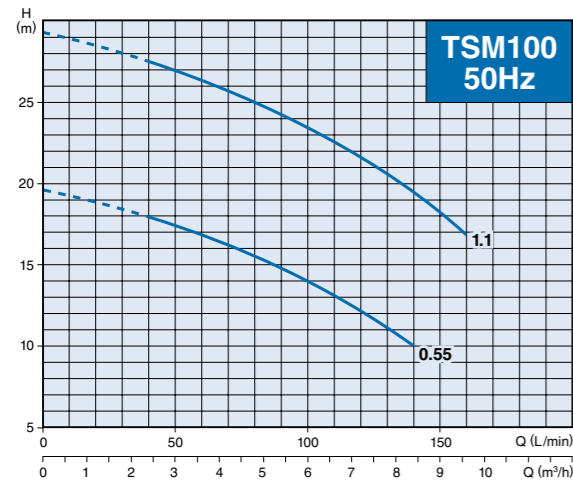

Performance Table

Model	Inlet x Outlet Bore (mm)	Motor Output (kW)	Q (L/min) Q (m³/h)	40	60	80	100	120	140	160
				2.4	3.6	4.8	6.0	7.2	8.4	9.6
TSM100-0.55	32 x 25	0.55	H	17.8	16.7	15.4	14	12.2	9.9	—
TSM100-1.1	32 x 25	1.1	(m)	27.4	26.3	25	23.4	21.5	19.5	16.7

TSMS100

Performance Curves

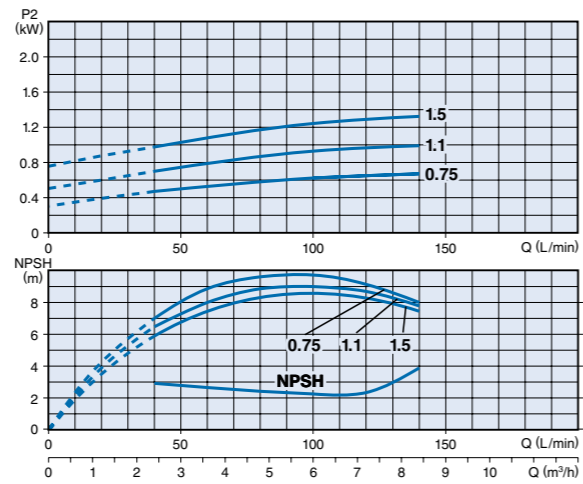
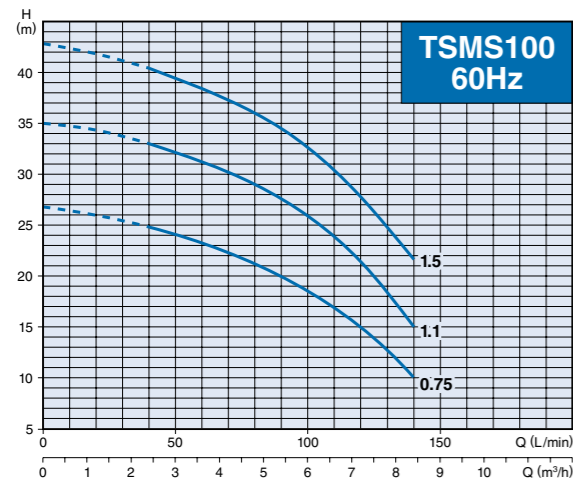

Performance Table

Model	Inlet x Outlet Bore (mm)	Motor Output (kW)	Q (L/min) Q (m³/h)	40	60	80	100	120	140
				2.4	3.6	4.8	6.0	7.2	8.4
TSMS100-0.75	32 x 25	0.75	H (m)	25	23	21	17	15	10
TSMS100-1.1	32 x 25	1.1		33	31	29	25	21	15
TSMS100-1.5	32 x 25	1.5		40	38	36	32	27	22

TSM160

Performance Curves

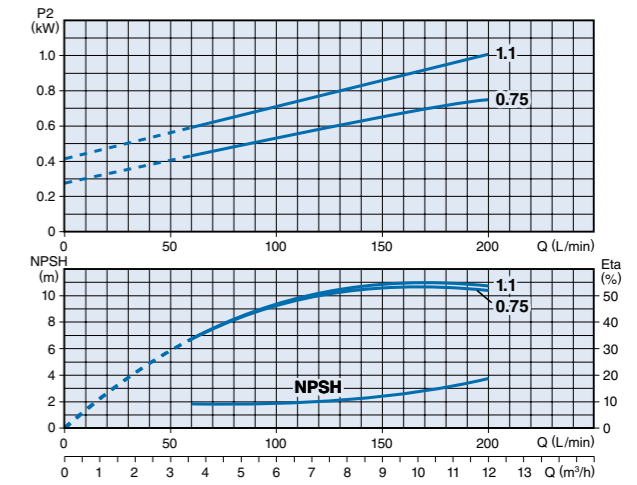
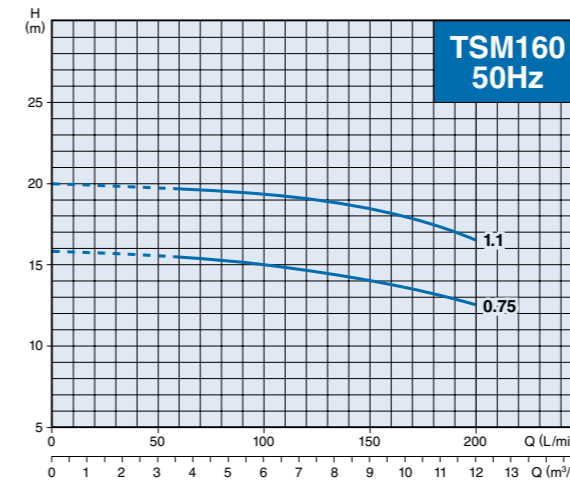

Performance Table

Model	Inlet x Outlet Bore (mm)	Motor Output (kW)	Q (L/min) Q (m³/h)	60	80	100	120	140	160	200
				3.6	4.8	6.0	7.2	8.4	9.6	12
TSM160-0.75	40 x 32	0.75	H	15.5	15.3	15	14.8	14.3	13.8	12.5
TSM160-1.1	40 x 32	1.1	(m)	19.7	19.5	19.3	19.1	18.7	18.2	16.5

TSMS160

Performance Curves

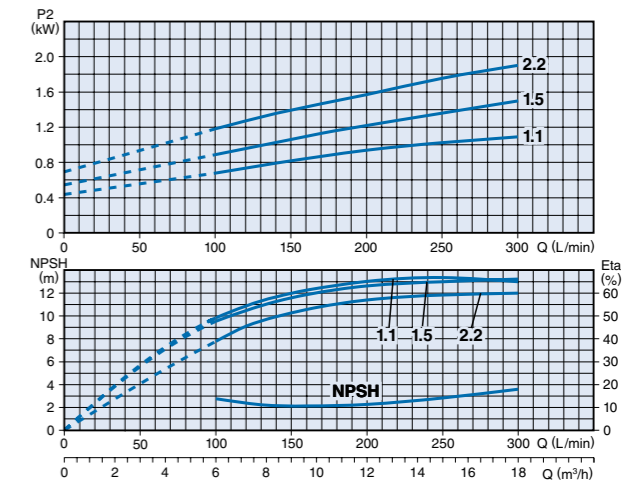
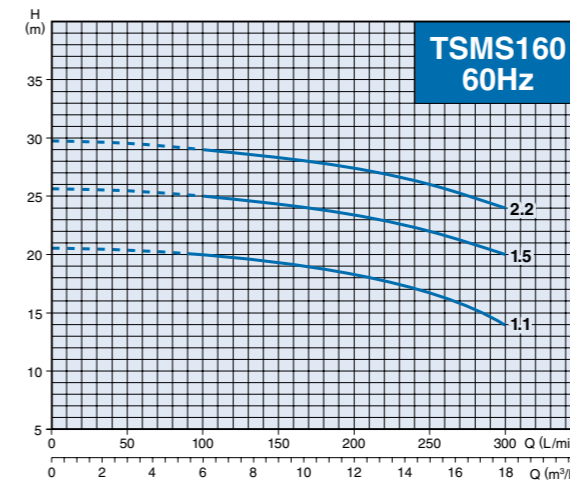

Performance Table

Model	Inlet x Outlet Bore (mm)	Motor Output (kW)	Q (L/min) Q (m³/h)	100	120	140	160	200	250	300
				6.0	7.2	8.4	9.6	12	15	18
TSMS160-1.1	40 x 32	1.1	H (m)	20.5	20	19.5	19	18	17	14
TSMS160-1.5	40 x 32	1.5		25.5	25	24.5	24	23	22	20
TSMS160-2.2	40 x 32	2.2		29	28.8	28.5	28	27.5	26	24

TSM250

Performance Curves

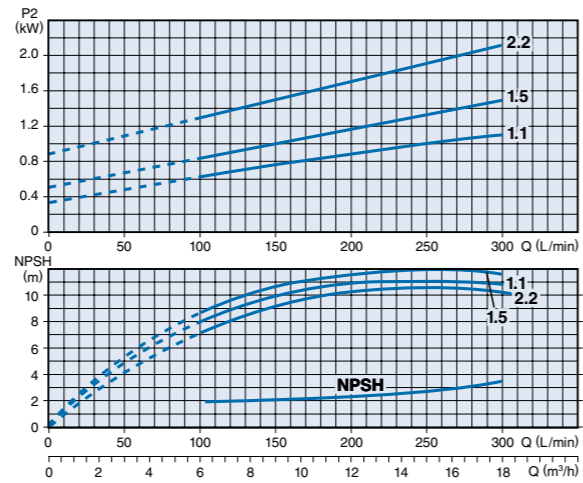
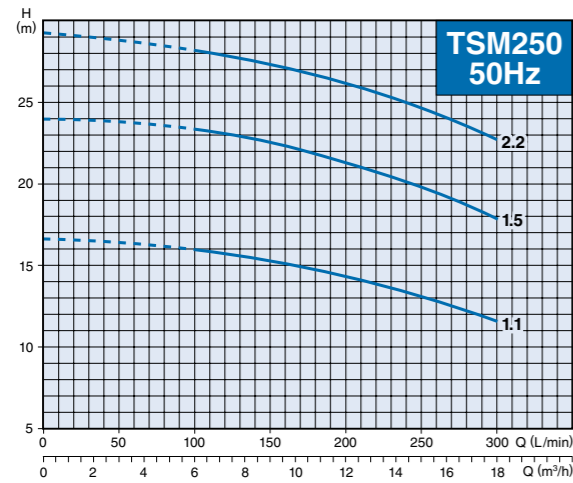

Performance Table

Model	Inlet x Outlet Bore (mm)	Motor Output (kW)	Q (L/min) Q (m³/h)	100	120	140	160	200	250	300
				H (m)						
TSM250-1.1	40 x 32	1.1		15.8	15.6	15.4	15	14.3	13	11.5
TSM250-1.5	40 x 32	1.5		23.2	23	22.7	22.2	21.4	19.8	17.7
TSM250-2.2	40 x 32	2.2		28.2	27.8	27.5	27	26.2	24.6	22.6

TSMS250

Performance Curves

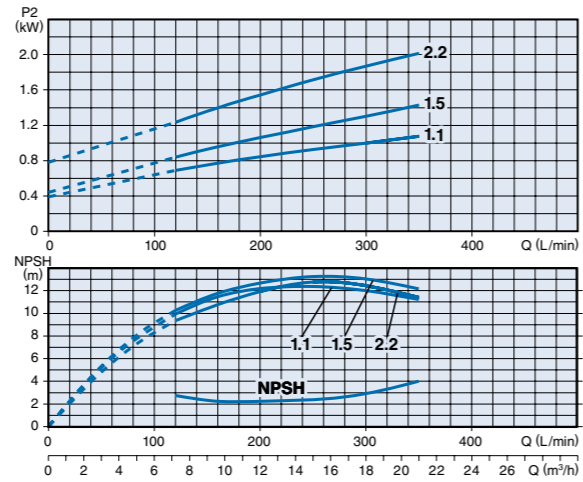
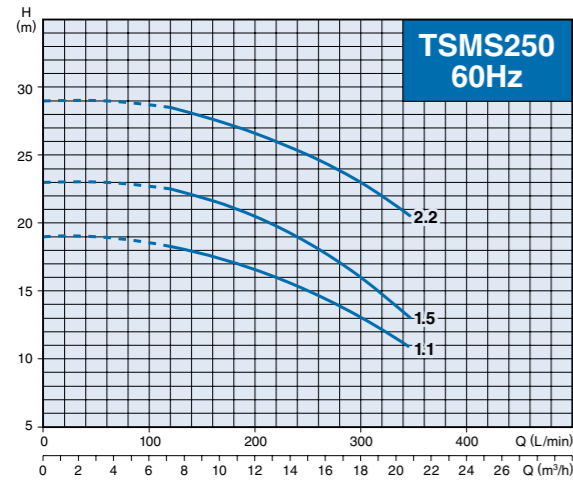

Performance Table

Model	Inlet x Outlet Bore (mm)	Motor Output (kW)	Q (L/min) Q (m³/h)	120	140	160	200	250	300	330	350
				H (m)							13
TSMS250-1.1	40 x 32	1.1		18.5	18	17.5	16.5	15	13	12	11
TSMS250-1.5	40 x 32	1.5		22.5	22	21.5	20.5	18.5	16	14	13
TSMS250-2.2	40 x 32	2.2		28.5	28	27.5	26.5	25	23	21.5	20.5

TSM330

Performance Curves

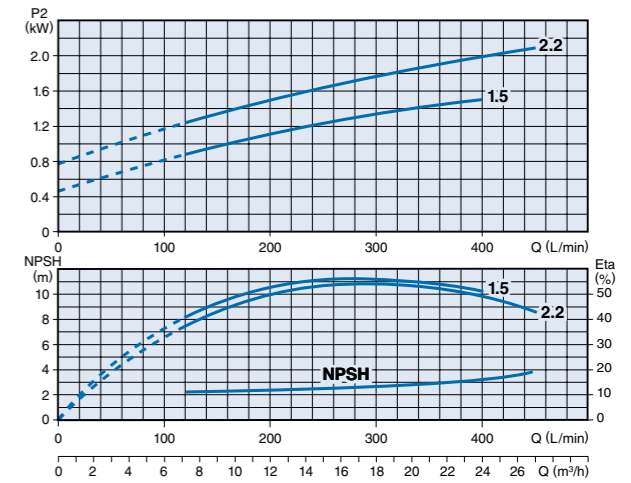
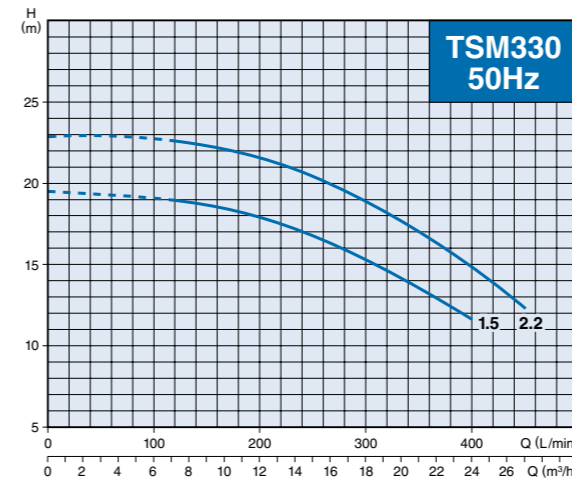

Performance Table

Model	Inlet x Outlet Bore (mm)	Motor Output (kW)	Q (L/min) Q (m³/h)	120	140	160	200	250	300	330	350	400	450
				H (m)									
TSM330-1.5	50 x 32	1.5		18.8	18.7	18.5	17.8	16.7	15	14	13.5	11.6	—
TSM330-2.2	50 x 32	2.2		22.5	22.2	22	21.5	20.3	18.7	17.5	16.8	14.8	12.3

TSMS330

Performance Curves

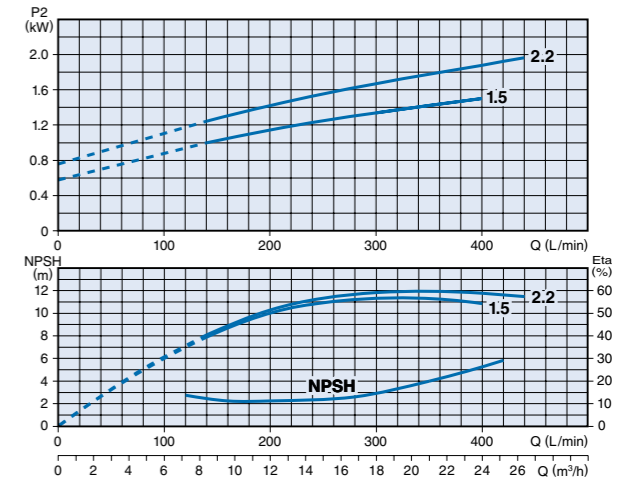
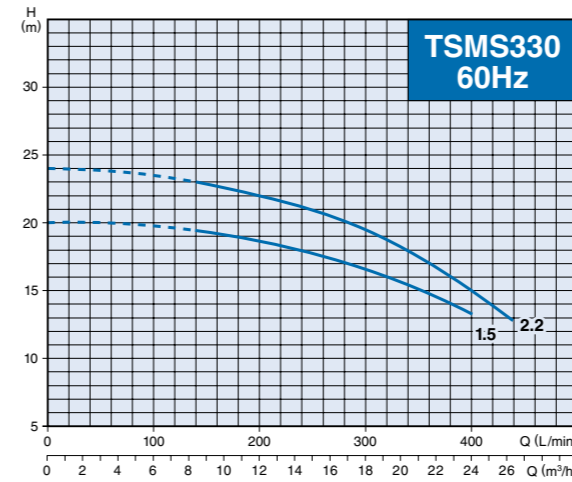

Performance Table

Model	Inlet x Outlet Bore (mm)	Motor Output (kW)	Q (L/min) Q (m³/h)	140	160	200	250	300	330	350	400	440
				H (m)								
TSMS330-1.5	50 x 32	1.5		19.5	19	18.5	18	16.5	16	15	13.5	—
TSMS330-2.2	50 x 32	2.2		23	22.5	22	20.5	19.5	18.5	17.5	15	12.8

Dimensions

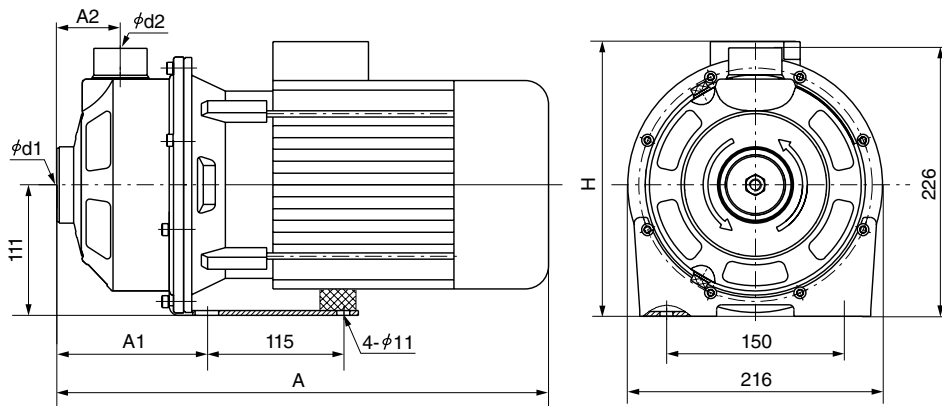

Unit: mm

Model	d1	d2	A	A1	A2	H		Dry Weight (kg)
						Phase		
						Single	Three	
TSM60-0.37	32	25	328	113	51	230	216	10
TSM60-0.55	32	25	328	113	51	230	216	12
TSM60-0.75	32	25	361	113	51	245	223	14
TSM100-0.55	32	25	328	113	51	230	216	12
TSM100-1.1	32	25	361	113	51	245	223	16
TSM160-0.75	40	32	375	127	54	245	223	14
TSM160-1.1	40	32	375	127	54	245	223	16
TSM250-1.1	40	32	375	127	54	245	223	16
TSM250-1.5	40	32	415	127	54	253	232	20
TSM250-2.2	40	32	415	127	54	253	232	23
TSM330-1.5	50	32	415	127	54	253	232	20
TSM330-2.2	50	32	415	127	54	253	232	23
TSMS100-0.75	32	25	361	113	51	245	223	14
TSMS100-1.1	32	25	361	113	51	245	223	14
TSMS100-1.5	32	25	401	113	51	253	232	20
TSMS160-1.1	40	32	375	127	54	245	223	16
TSMS160-1.5	40	32	415	127	54	253	232	20
TSMS160-2.2	40	32	415	127	54	253	232	23
TSMS250-1.1	40	32	375	127	54	245	223	16
TSMS250-1.5	40	32	415	127	54	253	232	20
TSMS250-2.2	40	32	415	127	54	253	232	23
TSMS330-1.5	50	32	415	127	54	253	232	20
TSMS330-2.2	50	32	415	127	54	253	232	23

We reserve the right to change the specifications and designs for improvement without prior notice.

**TSURUMI
MANUFACTURING CO., LTD.**

Your Dealer

Chainaris Phuket Engineering Co., Ltd.

63/13 Moo.2, T.Vichit, A.Muang Phuket 83000

Tel. 076-513100-3 Fax. 076-513105

www.chainaris.co.th

