

RSR-KS

ROTARY AIR BLOWERS



Rotary Air Blowers

Tsurumi's RSR-KS series rotary air blowers are equipped with a 3-lobe spur rotor. This rotor, as the most important component of a blower, is designed for corrosion resistance, heat resistance and durability, in addition to low noise, low vibration, ease of maintenance and high efficiency, thus providing stable performance, and ensuring smooth operation of the blower over a long period of time.

The product lineup of the RSR-KS series comprises air-cooled types (discharge bore diameter: 50 to 300 mm) and water-cooled types (discharge bore diameter: 80 to 350 mm) as standard models. Whether used under low pressure (0.6 kg/cm² or less) or high pressure (0.6 to 0.8 kg/cm²), the appropriate model can be selected according to application.

Use at 0.8 kg/cm² or higher pressure is available as a special specification. In addition, blowers can be equipped with a helical rotor (discharge bore diameter: 80 to 250 mm).

The RSR-KS series is suited for various applications, such as for aeration at wastewater treatment facilities, agitation of wastewater and sewage, decomposition and scum prevention, and oxygen supply at fish farms.

Tsurumi also offers other water treatment equipment besides blowers, including submersible pumps, aerators, mixers, scum skimmers, bar screens and dehydrators. These products have been tested and proven for many years in the field of water treatment, and can be supplied as a total package.

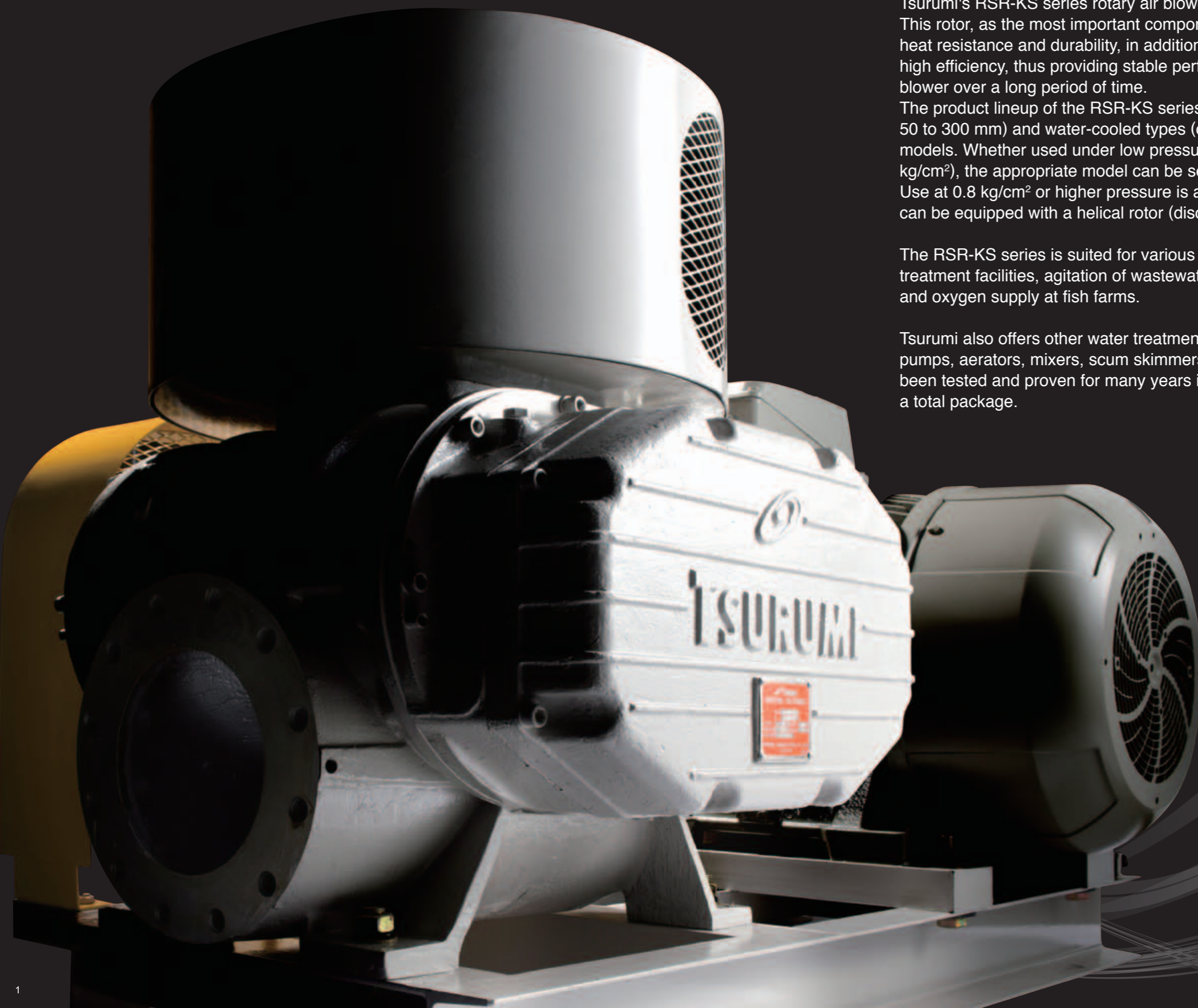

Blower with 3-lobe Spur Rotor

•Rotor

The 3-lobe spur rotor is designed for corrosion resistance, heat resistance and durability, in addition to low noise, low vibration and high efficiency operation.

•Casing

Fluid is drawn from the inlet on the upper stage and discharged from the side on the lower stage. This structure reduces noise and provides higher efficiency.

•Side Cover

The side cover supports the bearing and is structured to allow compressed air that has leaked via the shaft to flow out of the casing, without intrusion into other components. With water-cooled type blowers, cooling water is supplied to protect the bearing against temperature rise during operation at high pressure.

•Shaft

The shaft is made of carbon steel for mechanical structure, which has undergone precision machining for shrink-fitting in the rotor.

•Timing gear

The timing gear is made of chromium molybdenum steel. A Class 1 spur or helical gear is used to ensure stable power transmission, resulting in friction noise reduction.



Applications

- Aeration in sewage or industrial wastewater treatment plants
- As air-lift pumps in sewage or industrial wastewater treatment plants
- Oxygen supply at aquariums and fish farms
- Pneumatic conveyer



Installation Diagram

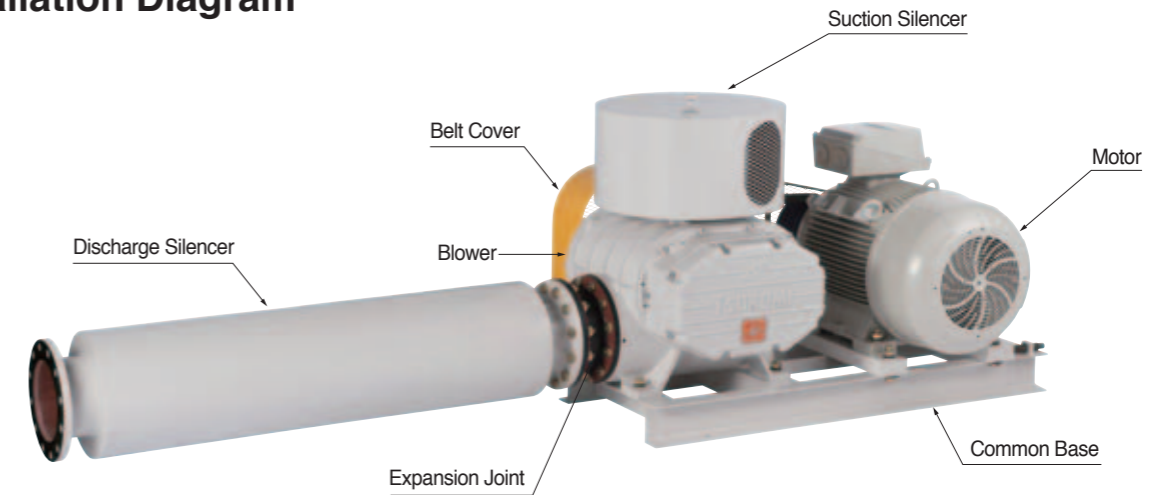

Standard Accessories

- Common Base
- Suction Silencer (with Air Filter)
- Discharge Silencer
- Belt Cover
- Flexi Check or Expansion Joint
- Pressure Gauge
- Safety Valve
- Pulley
- V-belt
- Anchor Bolts

Optional Accessories

- Gate Valve
- Anti-vibration Rubber
- Acoustic Hood
- Indoor Use Drip-proof Motor

Special Specifications

- Electroless Nickel Plating
- All Stainless Steel Version (Blower)

Model Number Designation

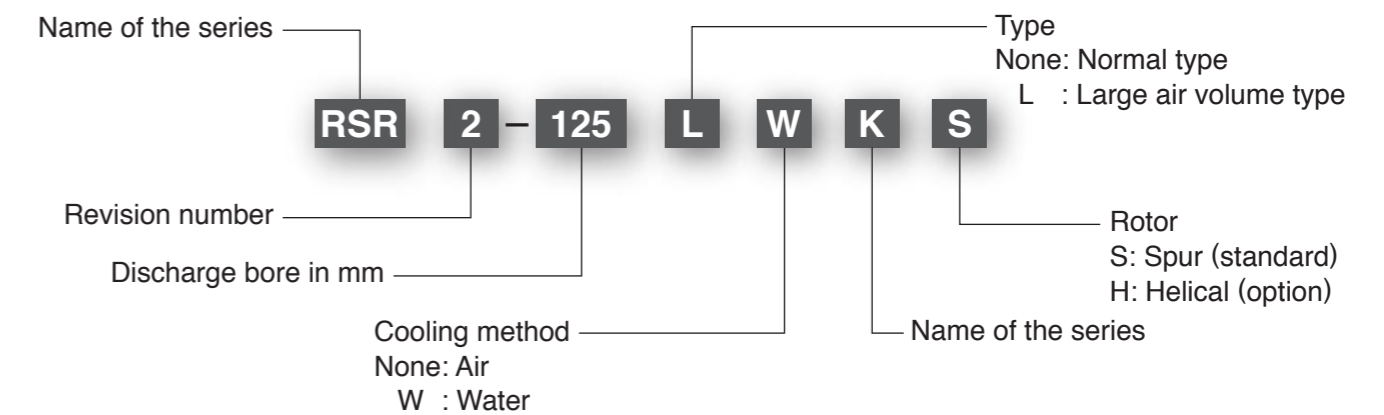

How To Select The Blower Model

The Selection Chart indicates the relationships between blower model, bores, revolutions, discharge pressures, actual air flow rates, and the shaft powers.

1. The amount of air indicated in the Selection Chart represents the suction amount under the following standard conditions: temperature 20°C, absolute pressure 101.3kPa, and relative humidity 70%.
2. The amount of air under reference conditions (0°C, absolute pressure 101.3kPa, dry) can be converted to amounts of air under standard suction conditions by the formula below if the suction pressures are the same:

$$Q_s = Q_n \times \frac{273 + t_s}{273}$$

where
 Q_s , amount of air (m³/min) under standard suction conditions indicated on the Selection Chart;
 Q_n , amount of air (m³/min) under reference suction conditions;
 Suction pressure is ambient pressure, 101.3kPa;
 t_s , suction temperature in °C

3. To convert amounts of air under discharge conditions to amounts of air under standard suction conditions indicated on the Selection Chart, use the following formula:

$$Q_s = Q_d \times \frac{101.3 + P_d}{101.3} \times \frac{273 + t_s}{273 + t_d}$$

Q_d , amount of air (m³/min.) under discharge conditions;
 P_d , discharge pressure (kPa)
 t_s , suction temperature in °C
 t_d , discharge temperature in °C

4. Using the amount of air and the necessary discharge pressure obtained from the above calculations, determine your blower model, bore, revolution, and shaft power referring to the Selection Chart.
5. Your selectable range can overlap several models. It is recommended that one with a smaller model number be selected for cost economy, or one with a larger model number be selected for lower noise.
6. For necessary motor output, refer to required power (La) in the Selection Chart.

RSR-KS -Air-Cooled Type-

Selection Chart (for reference)

Model (Discharge Bore in mm)	Speed (rpm)	Suction air volume at standard condition (Qs in m ³ /min) and required power (La in kW)											
		0.1kg/cm ² (9.8kPa)		0.2kg/cm ² (19.6kPa)		0.3kg/cm ² (29.4kPa)		0.4kg/cm ² (39.2kPa)		0.5kg/cm ² (49.0kPa)		0.6kg/cm ² (58.8kPa)	
		Qs	La	Qs	La	Qs	La	Qs	La	Qs	La	Qs	La
RSR2-50KS (50)	1240	1.46	0.74	1.26	1.07	1.12	1.37	0.99	1.68	0.86	2.02	0.72	2.32
	1450	1.79	0.87	1.58	1.23	1.42	1.58	1.27	1.94	1.12	2.31	1.00	2.68
	1750	2.25	1.02	2.03	1.48	1.87	1.95	1.72	2.41	1.57	2.88	1.45	3.34
	2100	2.84	1.24	2.58	1.82	2.40	2.39	2.23	2.98	2.05	3.57	1.91	4.16
RSR2-65KS (65)	1240	1.90	0.97	1.66	1.36	1.46	1.70	1.27	2.06	1.12	2.39	0.96	2.63
	1450	2.35	1.10	2.08	1.57	1.84	1.98	1.63	2.44	1.46	2.86	1.34	3.36
	1750	3.04	1.35	2.70	1.93	2.46	2.51	2.25	3.19	2.07	3.85	1.92	4.60
	2100	3.81	1.62	3.40	2.32	3.11	3.03	2.86	3.87	2.64	4.68	2.48	5.65
RSR2-80KS (80)	1150	3.72	1.45	3.31	2.16	2.96	2.74	2.67	3.31	2.37	3.76	2.14	4.19
	1450	5.09	1.79	4.68	2.75	4.33	3.60	4.04	4.50	3.75	5.36	3.52	6.20
	1750	6.46	2.09	6.05	3.27	5.70	4.36	5.41	5.55	5.12	6.73	4.88	7.91
	2100	8.14	2.51	7.64	3.94	7.22	5.27	6.88	6.71	6.53	8.17	6.24	9.63
RSR2-100KS (100)	1150	5.01	1.82	4.60	2.82	4.25	3.73	3.94	4.73	3.67	5.73	3.43	6.73
	1450	6.71	2.18	6.31	3.45	5.96	4.64	5.65	5.82	5.37	7.09	5.13	8.36
	1750	8.41	2.55	8.01	4.09	7.66	5.64	7.35	7.18	7.07	8.64	6.83	10.18
	2100	10.57	3.05	10.09	4.91	9.67	6.78	9.30	8.69	8.96	10.43	8.67	12.31
RSR2-125KS (125)	1180	8.22	2.59	7.74	4.17	7.31	5.75	6.94	7.33	6.70	8.92	6.40	10.50
	1470	10.78	3.32	10.27	5.38	9.89	7.44	9.51	9.51	9.19	11.63	8.94	13.96
	1750	13.13	3.98	12.63	6.43	12.26	8.88	11.88	11.33	11.57	13.98	11.32	16.63
	1960	15.16	4.45	14.65	7.19	14.29	9.99	13.92	12.81	13.62	15.88	13.39	18.98
RSR2-125LKS (125)	1180	13.29	3.90	12.50	6.27	11.81	8.65	11.22	11.02	10.83	13.40	10.33	15.77
	1470	17.23	4.89	16.42	7.92	15.82	10.95	15.21	13.98	14.70	17.11	14.29	20.53
	1750	21.00	5.85	20.20	9.45	19.60	13.06	19.00	16.67	18.50	20.57	18.10	24.46
	1960	23.99	6.55	23.19	10.59	22.61	14.70	22.02	18.85	21.55	23.37	21.18	27.93
RSR2-150KS (150)	1180	16.13	4.51	15.31	7.39	14.57	10.29	14.05	13.26	13.53	16.15	13.01	18.77
	1470	20.56	5.61	19.75	9.31	19.09	13.04	18.58	16.91	18.07	20.78	17.45	24.30
	1750	24.95	6.71	24.17	11.16	23.52	15.74	23.02	20.53	22.52	25.12	22.01	29.43
	1960	28.65	7.48	27.82	12.47	27.13	17.63	26.61	23.04	26.10	28.27	25.64	33.29
RSR2-150LKS (150)	1180	22.27	6.07	21.14	10.06	20.11	14.16	19.39	18.41	18.67	22.59	17.96	26.72
	1470	28.39	7.67	27.27	12.67	26.36	17.84	25.65	23.32	24.94	28.60	24.33	34.06
	1750	34.80	9.17	33.70	15.41	32.80	21.69	32.10	28.38	31.40	34.88	30.70	41.29
	1960	39.95	10.22	38.80	17.23	37.84	24.30	37.10	31.85	36.40	39.25	35.76	46.70
RSR2-200KS (200)	730	21.57	6.02	20.94	10.14	20.29	14.48	19.68	18.83	19.08	22.84	18.48	26.74
	880	26.52	7.11	25.78	12.22	25.14	17.46	24.43	22.70	23.87	27.53	23.44	32.23
	1100	34.24	8.82	33.40	15.18	32.63	21.98	31.93	28.56	31.24	34.70	30.84	40.98
	1470	47.85	11.71	46.98	20.36	45.87	29.27	44.99	38.12	44.42	46.57	43.84	55.38
RSR2-250KS (250)	800	36.82	9.75	35.86	16.43	34.81	23.47	33.95	30.51	33.09	37.01	32.23	43.33
	960	44.63	11.70	43.47	19.72	42.28	28.17	41.35	36.61	40.43	44.41	39.53	52.00
	1150	54.58	13.84	53.29	23.70	52.06	34.23	50.95	44.34	49.54	53.61	48.60	63.01
	1350	64.99	15.90	63.61	27.52	62.29	39.74	61.10	51.77	60.02	63.18	59.18	74.98
RSR2-300KS (300)	800	74.64	20.81	71.85	30.73	69.81	44.04	67.88	57.36	66.26	70.67	64.65	84.15
	960	91.31	24.37	88.39	36.98	86.23	53.40	84.35	69.87	82.61	86.15	80.78	102.14
	1150	110.48	29.20	107.47	44.52	105.15	64.48	103.07	84.53	101.13	104.43	99.5	124.5
	1350	130.99	34.27	128.05	52.52	125.29	76.06	123.17	100.01	121.21	123.93	119.7	148.4

1.5kW	7.5kW	22kW	55kW	132kW
2.2kW	11kW	30kW	75kW	150kW & over
3.7kW	15kW	37kW	90kW	
5.5kW	19kW	45kW	110kW	

- Note**
- The motor must be selected with 10 to 20% margin from the required power (La in kW).
 - The standard condition is defined as a temperature of 20°C, absolute pressure of 101.3kPa, and relative humidity of 70%.
 - For blowers with a discharge bore diameter of 80 to 250mm, the 3-lobe spur rotor can be exchanged with a helical rotor (option).
 - In case of operating at 0.6kg/cm² (58.8kPa), if you need a larger model, contact your dealer or Tsurumi representative.

Performance Curves (for reference)

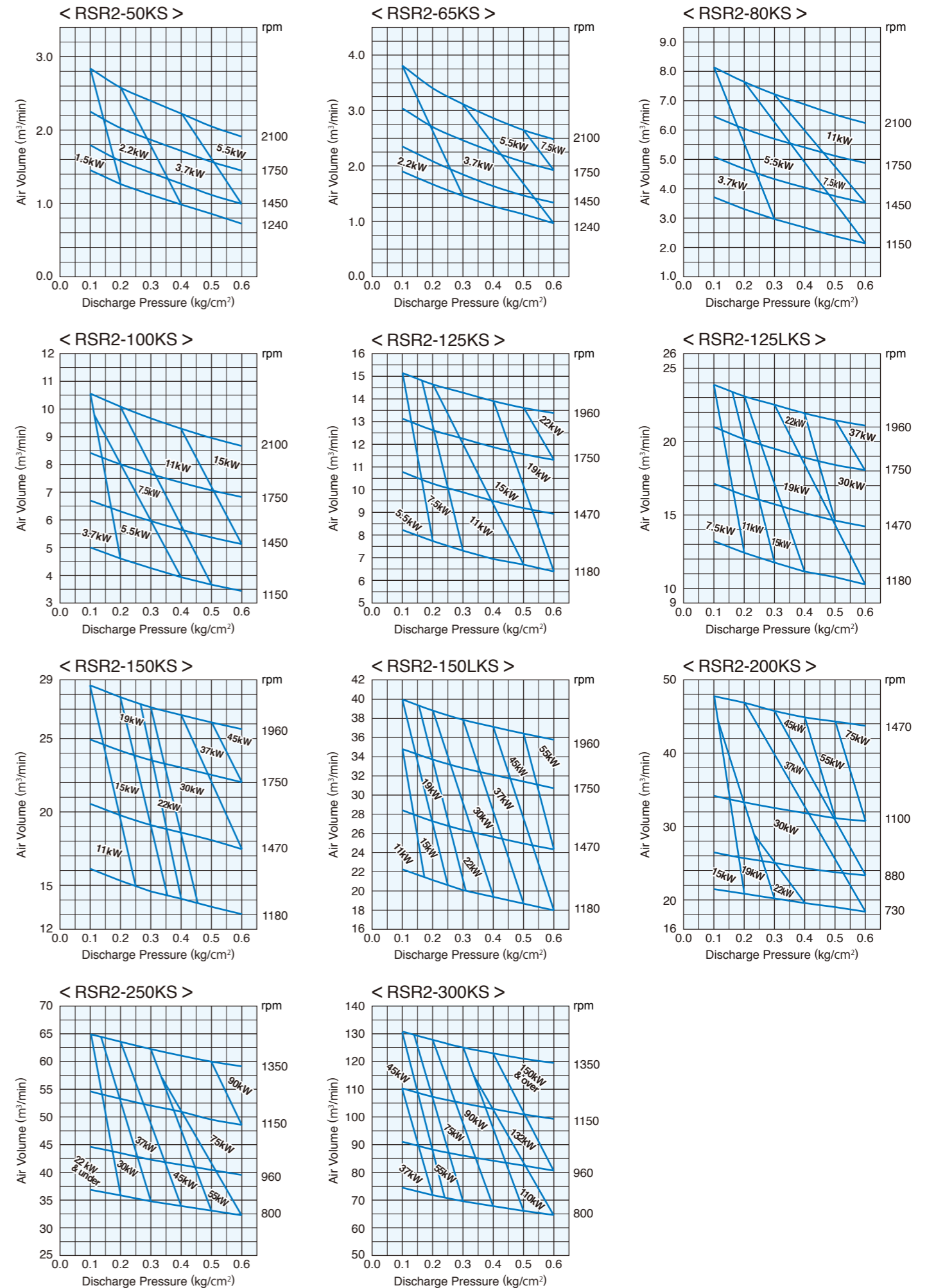

RSR-WKS -Water-Cooled Type-

Selection Chart (for reference)

Model (Discharge Bore in mm)	Speed (rpm)	Suction air volume at standard condition (Qs in m ³ /min) and required power (La in kW)										Cooling Water (L/min)
		0.4 kg/cm ² (39.2 kPa)		0.5 kg/cm ² (49.0 kPa)		0.6 kg/cm ² (58.8 kPa)		0.7 kg/cm ² (68.6 kPa)		0.8 kg/cm ² (78.5 kPa)		
		Qs	La	Qs	La	Qs	La	Qs	La	Qs	La	
RSR2-80WKS (80)	1150	2.67	3.70	2.39	4.31	2.16	4.89	1.94	5.44	1.76	6.08	6
	1300	3.35	4.33	3.06	5.13	2.82	5.85	2.62	6.66	2.44	7.50	
	1450	4.04	4.89	3.75	5.85	3.54	6.84	3.34	7.87	3.16	8.87	
	1500	4.21	5.02	3.91	6.02	3.68	7.04	3.49	8.12	3.31	9.15	
	1750	5.41	6.06	5.13	7.24	4.88	8.40	4.70	9.72	4.51	11.02	
RSR2-100WKS (100)	1150	3.94	5.14	3.67	6.22	3.43	7.29	3.22	8.38	3.03	9.60	8
	1450	5.65	6.49	5.37	7.84	5.12	9.23	4.90	10.65	4.70	12.03	
	1500	5.89	6.69	5.60	8.07	5.36	9.56	5.12	10.95	4.93	12.47	
	1750	7.33	7.76	7.00	9.40	6.72	11.05	6.44	12.73	6.17	14.39	
RSR2-125WKS (125)	1180	11.4	11.8	10.9	14.4	10.5	17.0	10.1	19.6	9.8	22.3	10
	1470	15.3	14.9	14.8	18.2	14.4	21.4	14.0	24.8	13.7	28.3	
	1750	19.1	17.5	18.6	21.4	18.2	25.2	17.8	29.1	17.5	33.1	
	1940	22.0	19.2	21.6	23.6	21.2	27.9	20.8	32.4	20.5	36.8	
RSR2-150WKS (150)	1180	19.8	19.0	19.1	23.4	18.4	27.6	17.9	32.1	17.3	36.3	13
	1470	25.8	23.5	25.2	28.9	24.5	34.0	23.9	39.3	23.3	44.4	
	1750	32.0	27.5	31.3	33.9	30.8	40.2	30.2	46.3	29.6	52.3	
	1940	36.8	30.3	36.1	37.2	35.5	44.1	34.9	51.0	34.4	57.7	
RSR2-200WKS (200)	880	37.3	34.1	36.3	41.7	35.5	49.6	34.6	57.4	33.8	65.6	16
	970	42.2	37.6	41.1	45.9	40.2	54.6	39.2	63.3	38.5	72.3	
	1100	49.1	42.5	48.1	52.3	47.1	62.0	46.1	71.9	45.1	81.6	
	1180	53.0	45.5	51.9	56.0	50.9	66.4	49.8	77.0	48.8	87.6	
	1470	67.2	56.5	66.0	69.9	64.8	83.1	63.7	96.3	62.6	109.5	
RSR2-200LWKS (200)	880	42.8	39.1	41.6	47.8	40.6	56.8	39.6	65.8	38.7	75.1	16
	970	48.3	43.0	47.1	52.6	46.1	62.6	45.0	72.5	44.1	82.8	
	1100	56.3	48.7	55.1	60.0	54.0	71.1	52.9	82.4	51.7	93.5	
	1180	60.7	52.1	59.5	64.2	58.3	76.0	57.1	88.2	55.9	100.4	
	1470	77.0	64.8	75.6	80.1	74.3	95.3	73.0	110.3	71.7	125.5	
RSR2-250WKS (250)	880	79.1	68.8	77.6	85.0	76.1	100.5	74.8	116.3	73.5	132.0	18
	980	89.9	76.7	88.3	94.7	86.8	112.0	85.4	129.5	84.1	147.0	
	1150	107.5	90.4	105.5	111.0	103.8	131.3	102.2	151.5	100.7	171.1	
	1280	122.2	100.8	120.3	123.7	118.4	146.0	116.4	167.8	114.7	189.1	
RSR2-300WKS (300)	730	94.8	82.8	92.9	102.7	91.2	122.6	89.5	141.9	87.8	161.4	20
	800	105.9	90.1	103.9	111.9	101.9	133.2	100.3	154.4	98.7	175.7	
	880	118.4	98.1	116.1	121.9	114.1	145.0	112.5	168.8	111.1	192.2	
	980	134.4	108.3	132.1	134.3	130.2	160.2	128.3	186.4	126.6	213.1	
	1150	161.9	127.2	159.4	157.3	157.2	187.1	155.1	216.2	153.5	246.4	
RSR2-350WKS (350)	580	162.6	141.0	159.3	173.4	156.0	205.9	153.2	237.1	150.5	269.2	25
	650	186.7	155.5	183.7	191.9	180.4	226.9	177.4	261.7	175.1	298.3	
	700	206.8	168.8	203.5	207.2	200.5	245.7	198.3	284.7	195.3	322.2	
	750	226.3	180.0	222.6	220.9	219.7	262.5	217.0	303.9	214.3	344.5	
	800	246.8	191.2	242.8	235.3	239.1	278.2	236.3	321.3	233.7	365.0	

Note

- The motor must be selected with 10 to 20% margin from the required power (La in kW).
- The standard condition is defined as a temperature of 20°C, absolute pressure of 101.3kPa, and relative humidity of 70%.
- For blowers with a discharge bore diameter of 80 to 250mm, the 3-lobe spur rotor can be exchanged with a helical rotor (option).
- In case of operating at 0.9kg/cm² (88.2kPa), if you need a larger model, contact your dealer or Tsurumi representative.

Performance Curves (for reference)

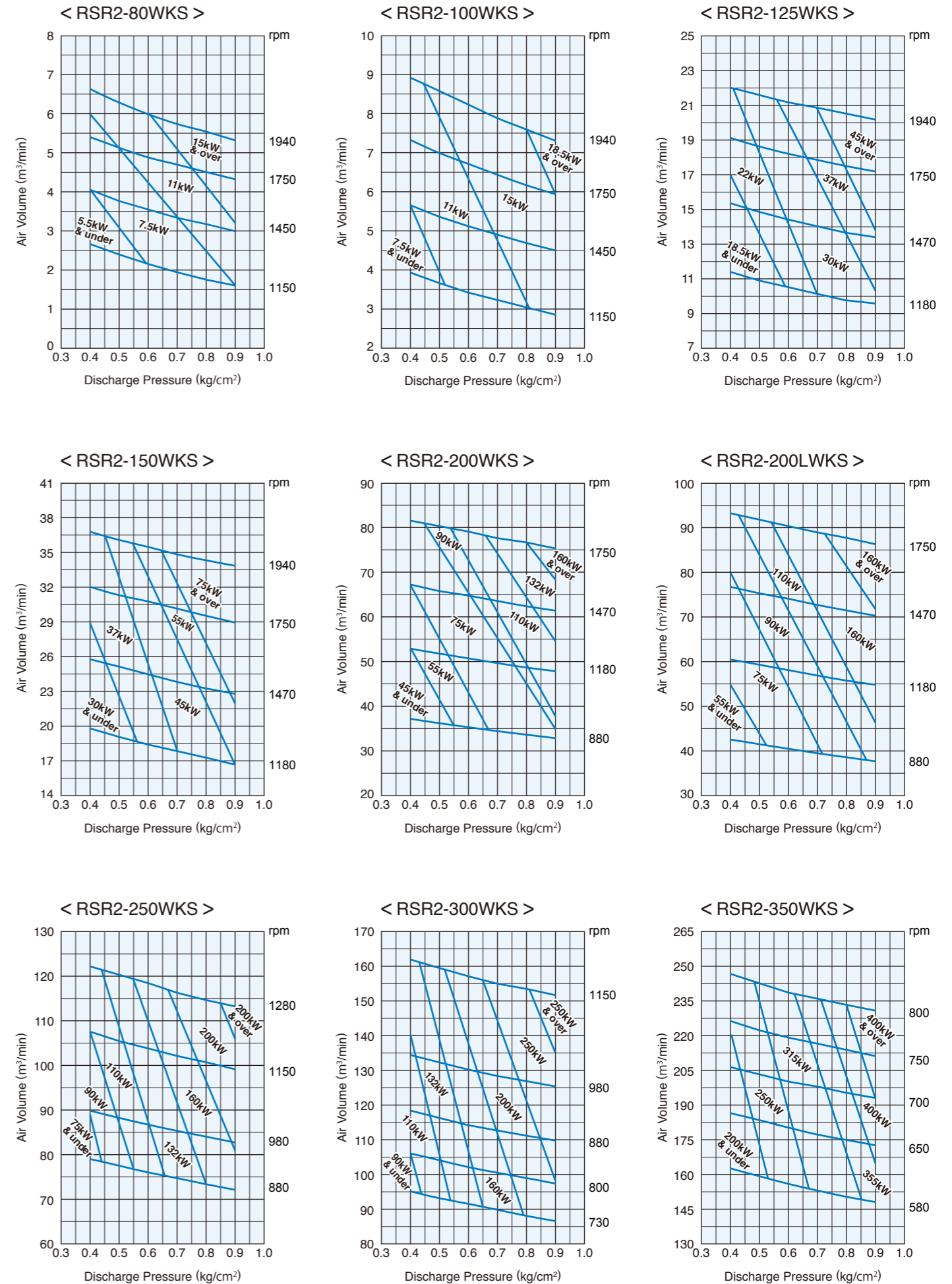

Dimensions

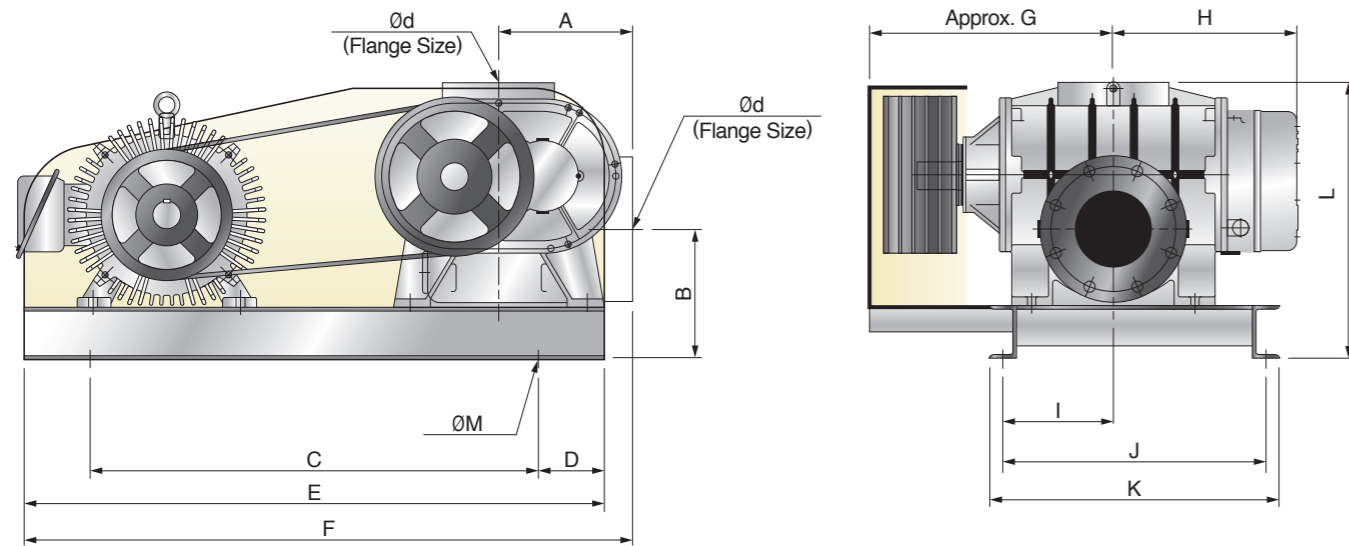

(unit: mm)

Model	Ød	A	B	C	D	E	F	G	H	I	J	K	L	ØM	Approx. Weight(kg)	
Air-Cooled Type	RSR2-50KS	50	135	160	450	100	650	680	210	160	120	260	300	290	14	54
	RSR2-65KS	65	135	160	450	100	650	680	230	180	145	260	300	290	14	57
	RSR2-80KS	80	175	190	550	100	750	775	245	215	125	280	320	380	18	109
	RSR2-100KS	100	175	190	600	100	800	825	280	230	120	400	440	380	18	119
	RSR2-125KS	125	205	235	650	100	850	900	350	260	120	370	420	434	18	201
	RSR2-125LKS	125	255	235	750	100	950	1005	360	275	135	430	480	505	18	263
	RSR2-150KS	150	255	250	750	100	950	1005	380	300	165	430	480	535	18	293
	RSR2-150LKS	150	255	250	850	125	1100	1155	465	350	210	500	550	535	18	324
	RSR2-200KS	200	310	300	950	125	1200	1235	505	370	245	500	560	650	23	486
	RSR2-250KS	250	350	360	1100	200	1500	1565	600	415	325	580	650	770	23	875
RSR2-300KS	300	460	415	1300	250	1800	1875	630	550	365	630	700	1005	23	1160	
Water-Cooled Type	RSR2-80WKS	80	190	200	600	150	900	920	350	240	135	360	400	430	18	158
	RSR2-100WKS	100	190	210	600	150	900	920	375	265	170	400	440	455	18	169
	RSR2-125WKS	125	255	255	800	200	1200	1255	430	325	195	440	490	575	18	316
	RSR2-150WKS	150	255	255	800	200	1200	1255	530	405	235	440	490	600	18	373
	RSR2-200WKS	200	355	300	1050	250	1550	1605	590	455	300	640	700	730	23	717
	RSR2-200LWKS	200	355	300	1050	250	1550	1605	650	490	330	640	700	730	23	920
	RSR2-250WKS	250	470	385	1400	200	1800	1920	800	570	405	730	800	990	23	1351
	RSR2-300WKS	300	520	480	1600	200	2000	2065	860	670	390	760	840	1145	23	1704
RSR2-350WKS	350	695	490	2200	200	2600	2730	820	790	450	920	1000	1280	23	3885	

*Weight excluding motor and silencer

Pumps and Water Treatment Equipment

Tsurumi can supply pumps and water treatment equipment as a total package.

Sewage & Wastewater Pump

B series

Discharge Bore : 50-800 mm
Motor Output : 0.4-110 kW



Jet Aerator

BER series

Air-inlet Bore : 25-50 mm
Motor Output : 0.75-5.5 kW



Aerator

TRN series

Air-inlet Bore : 32-150 mm
Motor Output : 0.75-40 kW



Mixer

MR series

Propeller Dia. : 145-400 mm
Motor Output : 0.25-4 kW



Floating Scum Skimmer

FSP series

Discharge Bore : 50 mm
Motor Output : 0.4-0.75 kW



Floating Decanter

FHP series

Discharge Bore : 40-80 mm
Motor Output : 0.25-1.5 kW



Bar Screen

KW series

Bar Spacing : 1-50 mm
Motor Output : 0.09 kW



Dehydrator

MDQ/MDC/JD series

Treating Capacity : 3-216 kgDS/h
Total Motor Output : 0.6-3.15 kW





We reserve the right to change the specifications and designs for improvement without prior notice.

**TSURUMI
MANUFACTURING CO., LTD.**

Your Dealer

[Chainaris Phuket Engineering Co., Ltd.](#)

63/13 Moo.2, T.Vichit, A.Muang Phuket 83000

Tel. 076-513100-3 Fax.076-513105

www.chainaris.co.th

