



# *Submersible Drainage Pumps*

## **KTV/KTVE KTZ/KRS**



## Compact, sturdy, and powerful submersible pumps Ideal for the most demanding construction jobs

Pumps must have solid structure, operate safe and easy, and offer high mobility. Now, you'll have to cap each of these attributes with the word "extra" when it comes to drainage pumps for construction work. Tsurumi has done it — not in word but in deed. Deliberately arranging on-the-job requirements in product design, Tsurumi has built a new series of extra powerful submersible pumps which ideally matches any demanding draining jobs. Each and every one of these products which represent Tsurumi's years of pump-making expertise has been hallmarked through daily work at many construction sites in the world.

### Built-in Oil Lifter (Patented)

This Oil Lifter was developed to improve quality and reliability of our submersible pump by enhancing sealing performance of the mechanical seal.

- \* The Oil Lifter is a lubrication device for the mechanical seal that is the heart of the submersible pump.
- \* The Oil Lifter stabilizes and enhances mechanical seal lubrication and cooling effect.
- \* Offers stable sealing performances even if the oil level drops. Facilitates periodic inspection.

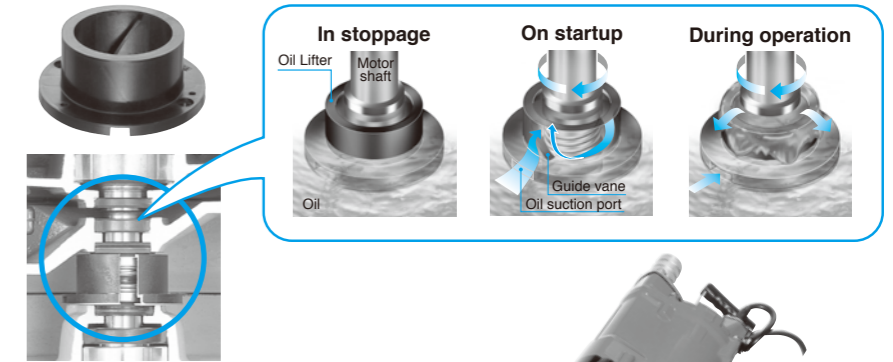

## KTV

### Submersible Semi-vortex Drainage Pumps

for General Construction Work 2-pole Motor Series

### Compact

The height has been reduced by a maximum of 181 mm (133 mm for KTV 2-15 and KTV 2-37) from Tsurumi's conventional equivalents by eliminating unnecessary room in the motor and the pump. These pumps are the smallest in this class in the industry.

### Lightweight

Pump materials have been changed in part to die-cast aluminum and specially treated synthetic rubber. This has reduced the weight of all models in this series by more than 10 kg compared with Tsurumi's conventional pumps of the same type. An ergonomically devised handle facilitates the relocation of the pump at a construction site.

### Rugged

The die-cast aluminum part is protected with the casing, wearing plate, and duct sleeve, all made of specially prepared synthetic rubber. This has resulted in amazingly increased resistance to wear and in the following additional virtues.

- Greatly reduced maintenance service intervals.
- A pump immune to calcium carbonate deposits or scale; if any, readily removed.
- No clogging, thanks to the semi-vortex flow construction.

### Low maintenance

The pump's lower part can be disassembled with a box wrench to facilitate maintenance services.

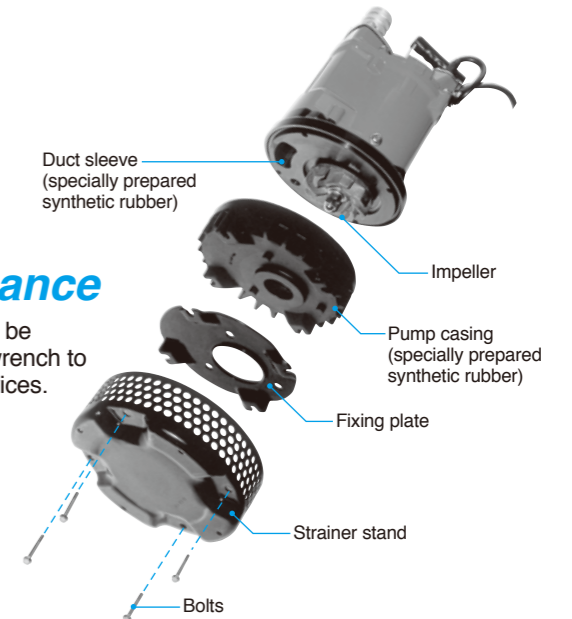

Lower part is disassembled with a box wrench for effortless maintenance without impeller removal.

## KTZ

### Submersible Drainage Pumps

for General Construction Work 2-pole Motor Series

### Rugged

The cast iron pump body presents a different way of top durability that can not be obtained by the aluminum body pumps. A choice is possible between high head version and high volume version in every motor size.



### Increased water-pressure resistance

A newly developed mechanical seal endures water pressure. This has made our KTZ submersible pumps usable at greater depth, such as in deep wells, to say nothing of use at general construction sites.

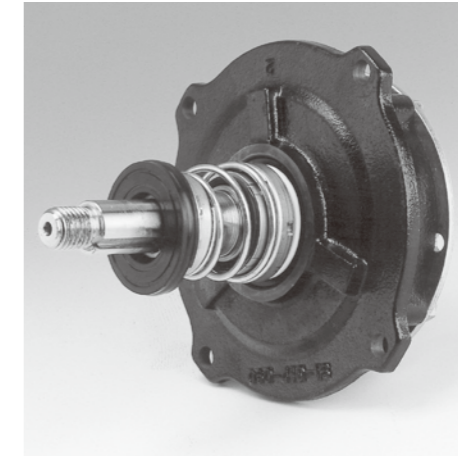

## KRS

### Submersible Drainage Pumps

for General Construction Work 4-pole Motor Series

### Rugged

KRS-series, another cast iron pumps with 4-pole motor, represent Tsurumi's multipurpose pumps for their simple construction, superb durability, and high efficiency. Tsurumi's years of expertise and innovative techniques are fully utilized in every component of these pumps which have own user's unparalleled credit and admiration.





Excellent durability secured by Tsurumi's long pump-making experience renders these pumps multipurpose ranging from construction work to installation in facilities.

### Major Standard Specifications

Item	Discharge bore (mm)		50	80
	Pumping fluid	Type of fluid	Rain water, Ground water, Sand carrying water	
Pump	Components	Liquid temperature	0 ~ 40°C	
		Impeller	Semi-vortex	
		Shaft seal	Double mechanical seal	
	Materials	Bearing	Shielded ball bearing	
		Impeller	Synthetic rubber(0.75kW) Ductile iron casting	
Motor	Casing	Synthetic rubber		
	Shaft seal (mechanical seal)	Silicon carbide		
	Type, Poles	Dry-type submersible induction motor, 2 poles		
Motor	Insulation	Class E		
	Phase / Voltage	Three-phase / 220V, 380V, 400V, 415V, 440V, 460V		
	Motor protector(Built-in)	Circle thermal protector		
	Lubricant	Turbine oil (ISO VG32)		
	Materials	Frame	Aluminum alloy casting	
Shaft		Stainless steel #420 / #403		
Cable		PVC Chloroprene rubber		
Discharge connection	Hose coupling			

### Standard Accessories

- Cabtyre cable ..... 1 pc
- Hose coupling ..... 1 pc
- Hose band (0.75kW only)..... 1 pc

### Optional Specifications

- Extended cable
- Special paint



### Performance Curves

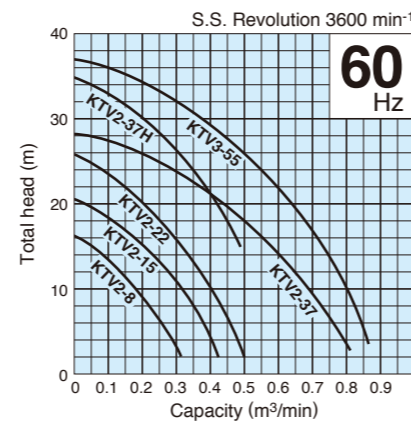
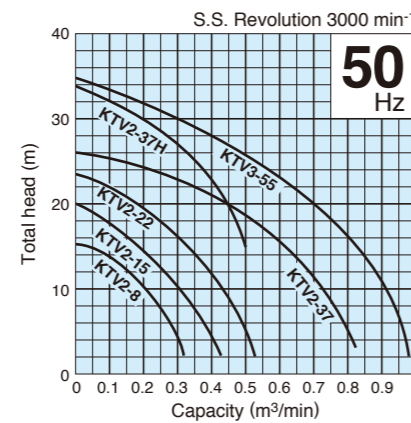

### Specifications 50/60Hz

Discharge Bore mm	Model	Motor Output kW	Phase	Total Head m	Capacity m³/min	Starting Method	Dry Weight kgs	Length of Cabtyre Cable m
50	KTV2-8	0.75	Three-phase	10	0.18	D.O.L.	11.5	5
50	KTV2-15	1.5	Three-phase	15	0.20	D.O.L.	20.5	8
50	KTV2-22	2.2	Three-phase	20	0.20	D.O.L.	23.0	8
50	KTV2-37H	3.7	Three-phase	30	0.20	D.O.L.	35.0	8
80	KTV2-37	3.7	Three-phase	18	0.50	D.O.L.	36.0	8
80	KTV3-55	5.5	Three-phase	22	0.60	D.O.L.	46.5	8

• Dry weight of the pump excluding cable.

### Dimensions Unit:mm

C.W.L.: Continuous Running Water Level

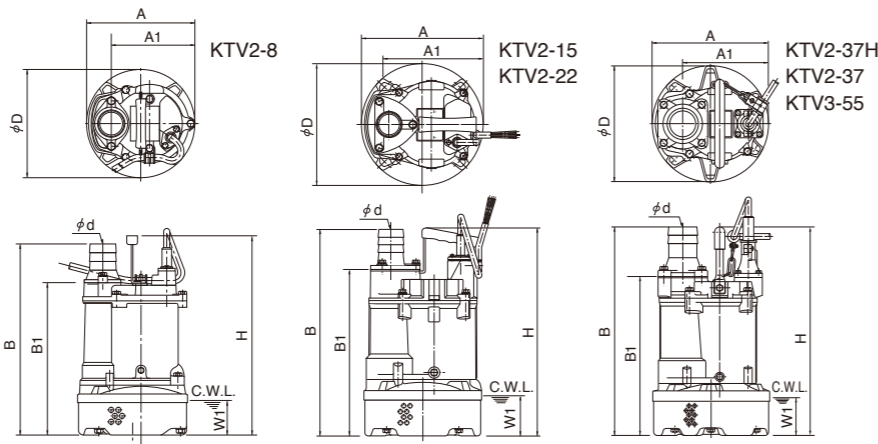

Model	d	A	A1	B	B1	D	H	W1
KTV2-8	50	200	155	353	281	200	369	65
KTV2-15	50	240	187	392	310	240	396	80
KTV2-22	50	240	187	412	330	240	416	80
KTV2-37H	50	285	211	510	387	285	510	90
KTV2-37	80	285	211	510	387	285	510	90
KTV3-55	80	300	229	545	422	300	545	90



### Probe type automatic pump (KTVE model)

Unit is turned on/off by probe-type water level sensor to prevent draught water flow when the water level drops.

Enhances durability of the pump itself by reducing radical part wear while saving energy.

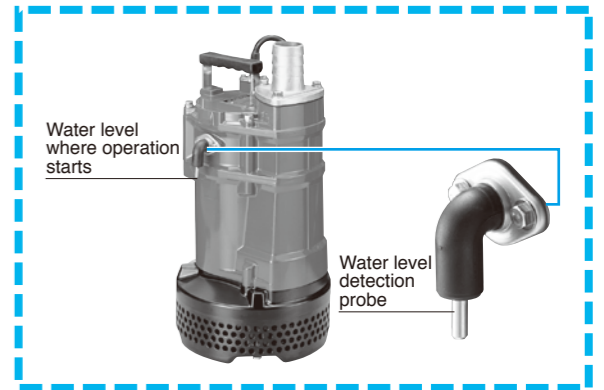

### Major Standard Specifications

Item	Discharge bore (mm)		50	80
	Pumping fluid	Type of fluid	Rain water, Ground water, Sand carrying water	
Pump	Components	Liquid temperature	0 ~ 40°C	
		Impeller	Semi-vortex	
		Shaft seal	Double mechanical seal	
	Materials	Bearing	Shielded ball bearing	
		Impeller	Synthetic rubber(0.75kW) Ductile iron casting	
Motor	Casing	Synthetic rubber		
	Shaft seal (mechanical seal)	Silicon carbide		
	Type, Poles	Dry-type submersible induction motor, 2 poles		
Motor	Insulation	Class E		
	Phase / Voltage	Three-phase / 220V, 380V, 400V, 415V, 440V, 460V		
	Motor protector(Built-in)	Circle thermal protector		
	Lubricant	Turbine oil (ISO VG32)		
	Materials	Frame	Aluminum alloy casting	
Shaft		Stainless steel #420 / #403		
Cable		PVC Chloroprene rubber		
Discharge connection	Hose coupling			

### Standard Accessories

- Cabtyre cable ..... 1 pc
- Hose coupling ..... 1 pc
- Hose band (0.75kW only)..... 1 pc

### Optional Specifications

- Extended cable
- Special paint

### Performance Curves

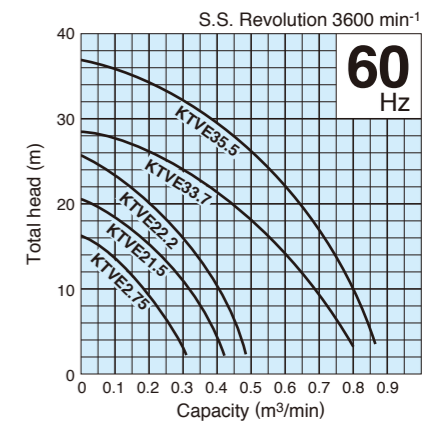
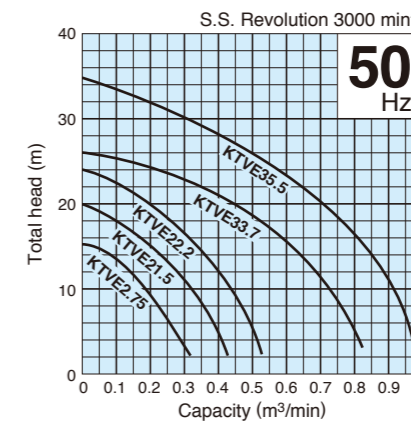

### Specifications 50/60Hz

Discharge Bore mm	Model	Motor Output kW	Phase	Total Head m	Capacity m³/min	Starting Method	Dry Weight kgs	Length of Cabtyre Cable m
50	KTVE2.75	0.75	Three-phase	10	0.18	D.O.L.	12.7	5
50	KTVE21.5	1.5	Three-phase	15	0.20	D.O.L.	21.5	8
50	KTVE22.2	2.2	Three-phase	20	0.20	D.O.L.	24.5	8
80	KTVE33.7	3.7	Three-phase	18	0.50	D.O.L.	39.5	8
80	KTVE35.5	5.5	Three-phase	22	0.60	D.O.L.	52.0	8

• Dry weight of the pump excluding cable.

### Dimensions Unit:mm

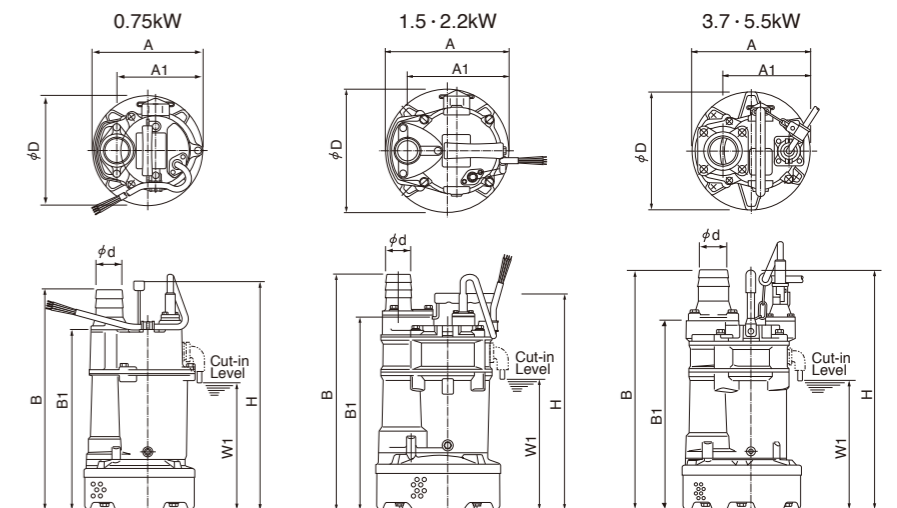

Model	d	A	A1	B	B1	D	H	W1
KTVE2.75	50	200	155	401	329	200	417	234
KTVE21.5	50	240	187	462	380	240	426	266
KTVE22.2	50	240	187	462	380	240	426	266
KTVE33.7	80	285	210	585	462	285	585	327
KTVE35.5	80	300	229	620	497	300	620	357

Efficient motor cooling by a side-flow channel ; Space economy by a top outlet.

### Performance Curves

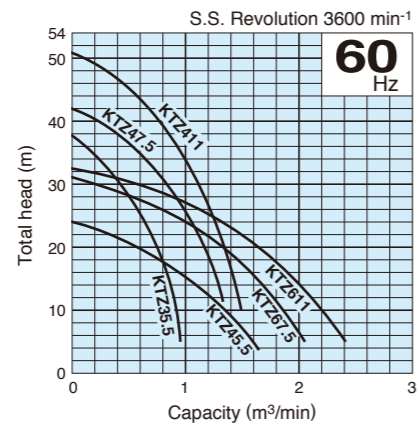
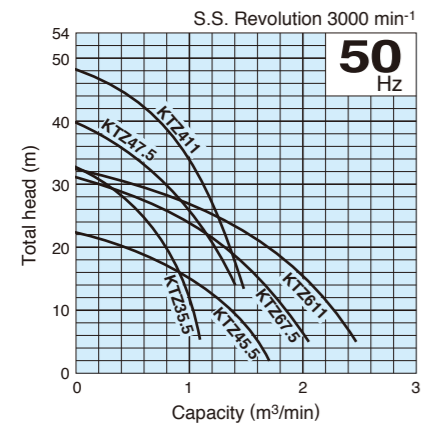
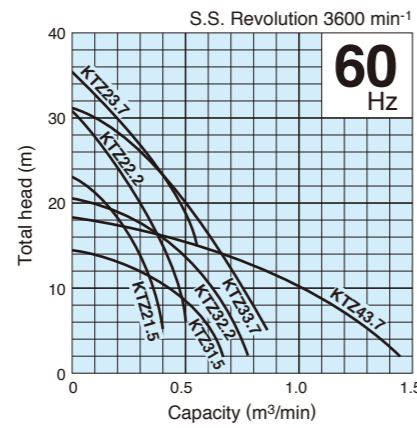
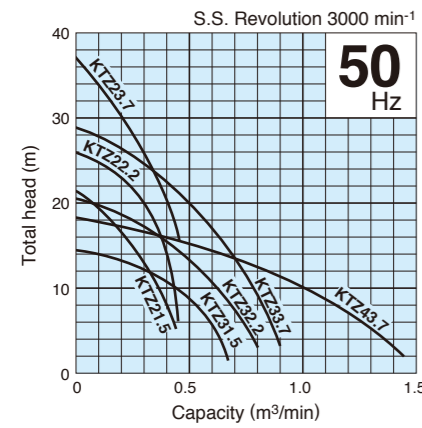

### Specifications 50/60Hz

Discharge Bore mm	Model	Motor Output kW	Phase	Total Head m	Capacity m³/min	Starting Method	Dry Weight kgs	Length of Cable m
50	KTZ21.5	1.5	Three-phase	15.0/16.5	0.25	D.O.L.	30	8
50	KTZ22.2	2.2	Three-phase	20.0	0.30	D.O.L.	34	8
50	KTZ23.7	3.7	Three-phase	30.0	0.20	D.O.L.	62.5	8
80	KTZ31.5	1.5	Three-phase	8.0	0.50	D.O.L.	30	8
80	KTZ32.2	2.2	Three-phase	10.0	0.60	D.O.L.	34	8
80	KTZ33.7	3.7	Three-phase	20.0	0.50	D.O.L.	62.5	8
100	KTZ43.7	3.7	Three-phase	10.0	1.00	D.O.L.	62.5	8
80	KTZ35.5	5.5	Three-phase	25.0	0.60	D.O.L.	82	8
100	KTZ45.5	5.5	Three-phase	15.0	1.00	D.O.L.	82	8
100	KTZ47.5	7.5	Three-phase	30.0	0.80	D.O.L.	105	8
100	KTZ41.1	11	Three-phase	35.0	1.00	D.O.L.	133	8
150	KTZ67.5	7.5	Three-phase	15.0	1.60	D.O.L.	107	8
150	KTZ61.1	11	Three-phase	20.0	1.70	D.O.L.	136	8

• Dry weight of the pump excluding cable.

### Dimensions Unit:mm

C.W.L.: Continuous Running Water Level

Model	d	A	A1	B	B1	D	H	W1
KTZ21.5	50	235	173	509	401	216	478	120
KTZ31.5	80	235	173	509	401	216	478	120
KTZ22.2	50	235	173	529	421	216	498	120
KTZ32.2	80	235	173	529	421	216	498	120
KTZ23.7	50	283	208	627	504	252	637	150
KTZ33.7	80	283	208	627	504	252	637	150
KTZ35.5	80	306	218	671	548	259	688	150
KTZ45.5	100	306	218	686	548	259	688	150
KTZ47.5	100	330	240	764	626	314	687	190
KTZ67.5	150	330	240	799	626	314	687	190
KTZ41.1	100	373	260	806	645	350	740	190
KTZ61.1	150	373	260	826	645	350	740	190

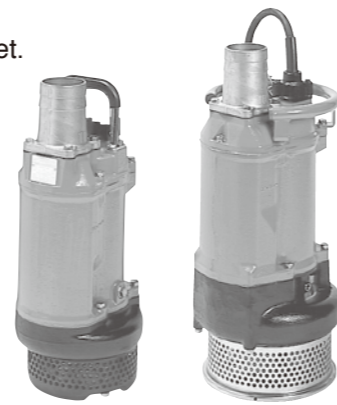

### Major Standard Specifications

Item	Discharge bore (mm)	50	80	100	150
Pumping fluid	Type of fluid	Spring water, Rain water, Ground water, Sand carrying water			
	Liquid temperature	0 ~ 40°C			
Pump	Components	Impeller: Semi-open type			
		Shaft seal: Double mechanical seal, Water pressure endurance			
		Bearing: Shielded ball bearing			
		Impeller: Chromium iron casting			
		Casing: Gray iron casting			
		Suction cover: Ductile iron casting			
Motor	Materials	Shaft seal (mechanical seal): Silicon carbide			
	Type, Poles	Dry-type submersible induction motor, 2 poles			
	Insulation	Class F			
	Phase / Voltage	Three-phase / 220V, 380V, 400V, 415V, 440V, 460V			
	Motor protector(Built-in)	Circle thermal protector			
	Lubricant	Turbine oil (ISO VG32)			
Materials	Frame	Gray iron casting			
	Shaft	Stainless steel #420			
	Cable	PVC Chloroprene rubber			
Discharge connection	Hose coupling				

### Standard Accessories

- Cabtyre cable ..... 1 pc
- Hose coupling ..... 1 pc

### Optional Specifications

- Extended cable
- Special paint

C.W.L.: Continuous Running Water Level

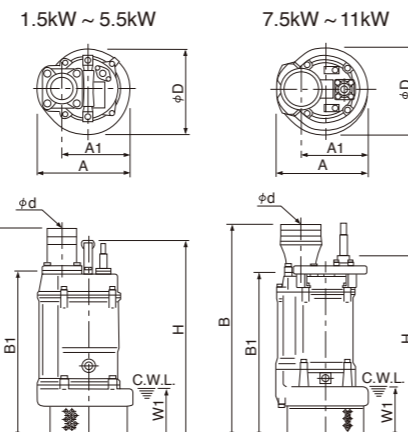

A wide variety of models offer the perfect freedom of choosing the most suitable one.



### Performance Curves

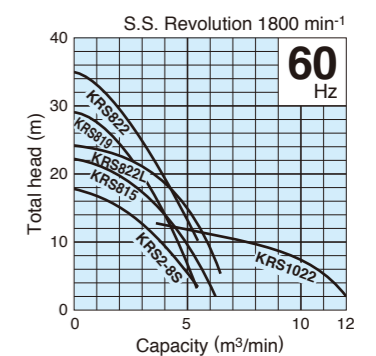
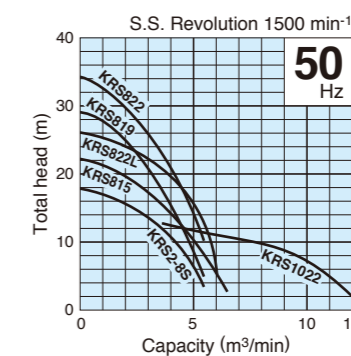
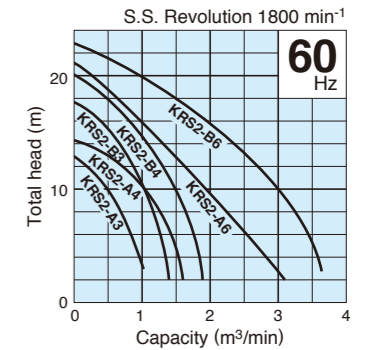
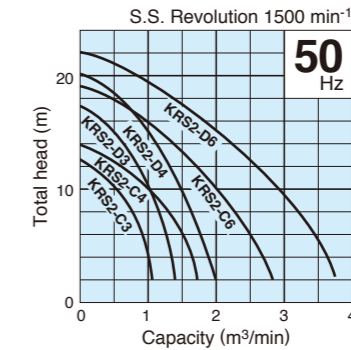

### Major Standard Specifications

Item	Discharge bore (mm)	80	100	150	200	250
Pumping fluid	Type of fluid	Rain water, Ground water, Sand carrying water				
	Liquid temperature	0 ~ 40°C				
Pump	Components	Impeller: Semi-open type, Closed type (KRS1022)				
		Shaft seal: Double mechanical seal				
		Bearing: Shielded ball bearing				
		Impeller: Ductile iron casting				
		Casing: Gray iron casting				
		Suction cover: Gray iron casting				
Motor	Materials	Shaft seal (mechanical seal): Silicon carbide				
	Type, Poles	Dry-type submersible induction motor, 4 poles				
	Insulation	Class E, B, F				
	Phase / Voltage	Three-phase / 220V, 380V, 400V, 415V, 440V, 460V				
	Motor protector(Built-in)	Circle thermal protector				
	Lubricant	Turbine oil (ISO VG32)				
Materials	Frame	Gray iron casting				
	Shaft	Stainless steel #420				
	Cable	Chloroprene rubber				
Discharge connection	Hose coupling					

### Standard Accessories

- Cabtyre cable ..... 1 pc
- Hose coupling ..... 1 pc

### Optional Specifications

- Extended cable
- Special paint

### Dimensions Unit:mm

C.W.L.: Continuous Running Water Level

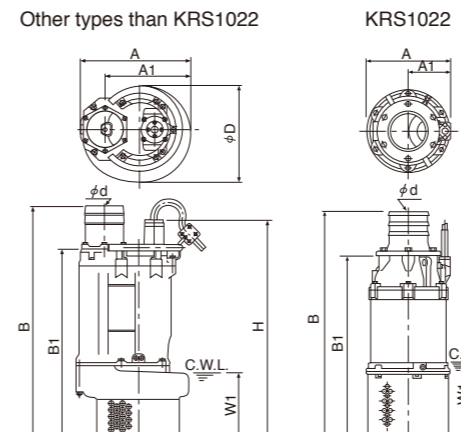

### Specifications 50/60Hz

Discharge Bore mm	Model	Motor Output kW	Phase	Total Head m	Capacity m³/min	Starting Method	Dry Weight kgs	Length of Cable m
80	KRS2-C3/A3	2.2	Three-phase	10	0.5	D.O.L.	72	8
80	KRS2-D3/B3	3.7	Three-phase	15	0.5	D.O.L.	91/89	8
100	KRS2-C4/A4	3.7	Three-phase	10	1.0	D.O.L.	88	8
100	KRS2-D4/B4	5.5	Three-phase	15	1.0	D.O.L.	98/95	8
150	KRS2-C6/A6	7.5	Three-phase	10	2.0	D.O.L.	130	8
150	KRS2-D6/B6	11	Three-phase	15	2.0	D.O.L.	158/150	8
200	KRS2-8S	11	Three-phase	10	4.0	D.O.L.	174	8
200	KRS815	15	Three-phase	15	4.0	D.O.L.	240	8
200	KRS819	18.5	Three-phase	20/15	3.0/4.0	D.O.L.	360	10
200	KRS822	22	Three-phase	30/20	2.0/4.0	D.O.L.	380	10
200	KRS822L	22	Three-phase	15	5.0	D.O.L.	380	10
250	KRS1022	22	Three-phase	10	8.0	D.O.L.	390	10

• Dry weight of the pump excluding cable.

Model	d	A	A1	B	B1	D	H	W1
KRS2-C3/A3	80	340	255	620	499	315	600	145
KRS2-D3	80	365	275	705	584	350	685	155
KRS2-B3	80	350	260	705	584	320	685	155
KRS2-C4/A4	100	350	260	720	584	320	685	155
KRS2-D4	100	365	275	710	574	350	675	155
KRS2-B4	100	350	260	710	574	320	675	155
KRS2-C6	150	415	305	767	585	373	685	175
KRS2-A6	150	415	305	767	585	373	685	175
KRS2-D6	150	434	324	813	632	407	744	180
KRS2-B6	150	415	305	812	630	373	742	175
KRS2-8S	200	472	356	933	701	403	814	300
KRS815	200	481	347	1069	837	440	949	275
KRS819	200	572	445	1238	1006	530	1156	345
KRS822	200	572	445	1238	1006	530	1156	345
KRS822L	200	572	445	1238	1006	530	1156	345
KRS1022	250	520	250	1439	1156	—	—	450

The low head version is equipped with a specially developed motor to minimize unnecessary power consumption for maximal cost economy.

### Performance Curves

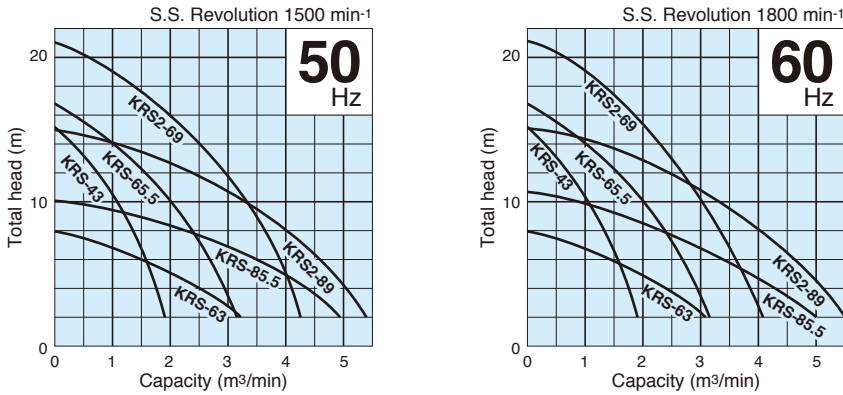

### Specifications 50/60Hz

Discharge Bore mm	Model	Motor Output kW	Phase	Total Head m	Capacity m³/min	Starting Method	Dry Weight kgs	Length of Cabtyre Cable m
100	KRS-43	3.0	Three-phase	10	1.0	D.O.L.	95	8
150	KRS-63	3.0	Three-phase	5	2.0	D.O.L.	95	8
150	KRS-65.5	5.5	Three-phase	10	2.0	D.O.L.	115	8
150	KRS2-69	9.0	Three-phase	16	2.0	D.O.L.	155	8
200	KRS-85.5	5.5	Three-phase	5	3.8	D.O.L.	125	8
200	KRS2-89	9.0	Three-phase	8	4.0	D.O.L.	175	8

• Dry weight of the pump excluding cable.

### Dimensions Unit:mm

C.W.L.: Continuous Running Water Level

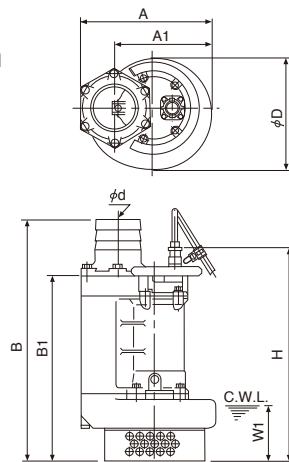

Model	d	A	A1	B	B1	D	H	W1
KRS-43	100	378	288	723	561	347	622	170
KRS-63	150	384	294	866	686	365	747	300
KRS-65.5	150	425	305	790	608	370	669	190
KRS2-69	150	490	372	812	630	424	742	200
KRS-85.5	200	446	326	941	710	413	771	295
KRS2-89	200	473	355	933	701	408	813	300

### Major Standard Specifications

Item	Discharge bore (mm)		
	100	150	200
Pumping fluid	Type of fluid	Rain water, Ground water, Sand carrying water	
	Liquid temperature	0 ~ 40°C	
Pump	Components	Impeller	Semi-open type, Closed type (KRS-63~85.5)
		Shaft seal	Double mechanical seal
		Bearing	Shielded ball bearing
	Materials	Impeller	Ductile iron casting
		Casing	Gray iron casting
Shaft seal (mechanical seal)	Silicon carbide		
Motor	Type, Poles	Dry-type submersible induction motor, 4 poles	
	Insulation	Class E, B	
	Phase / Voltage	Three-phase / 220V, 380V, 400V, 415V, 440V, 460V	
	Motor protector(Built-in)	Circle thermal protector	
	Lubricant	Turbine oil (ISO VG32)	
Materials	Frame	Gray iron casting	
	Shaft	Stainless steel #420	
	Cable	Chloroprene rubber	
Discharge connection	Hose coupling		

### Standard Accessories

- Cabtyre cable .....1 pc
- Hose coupling .....1 pc

### Optional Specifications

- Extended cable
- Special paint

We reserve the right to change the specifications and designs for improvement without prior notice.

**TSURUMI**  
MANUFACTURING CO., LTD.

Your Dealer



Chainaris Phuket Engineering Co., Ltd.  
63/13 Moo.2, T.Vichit, A.Muang Phuket 83000  
Tel. 076-513100-3 Fax. 076-513105  
www.chainaris.co.th