

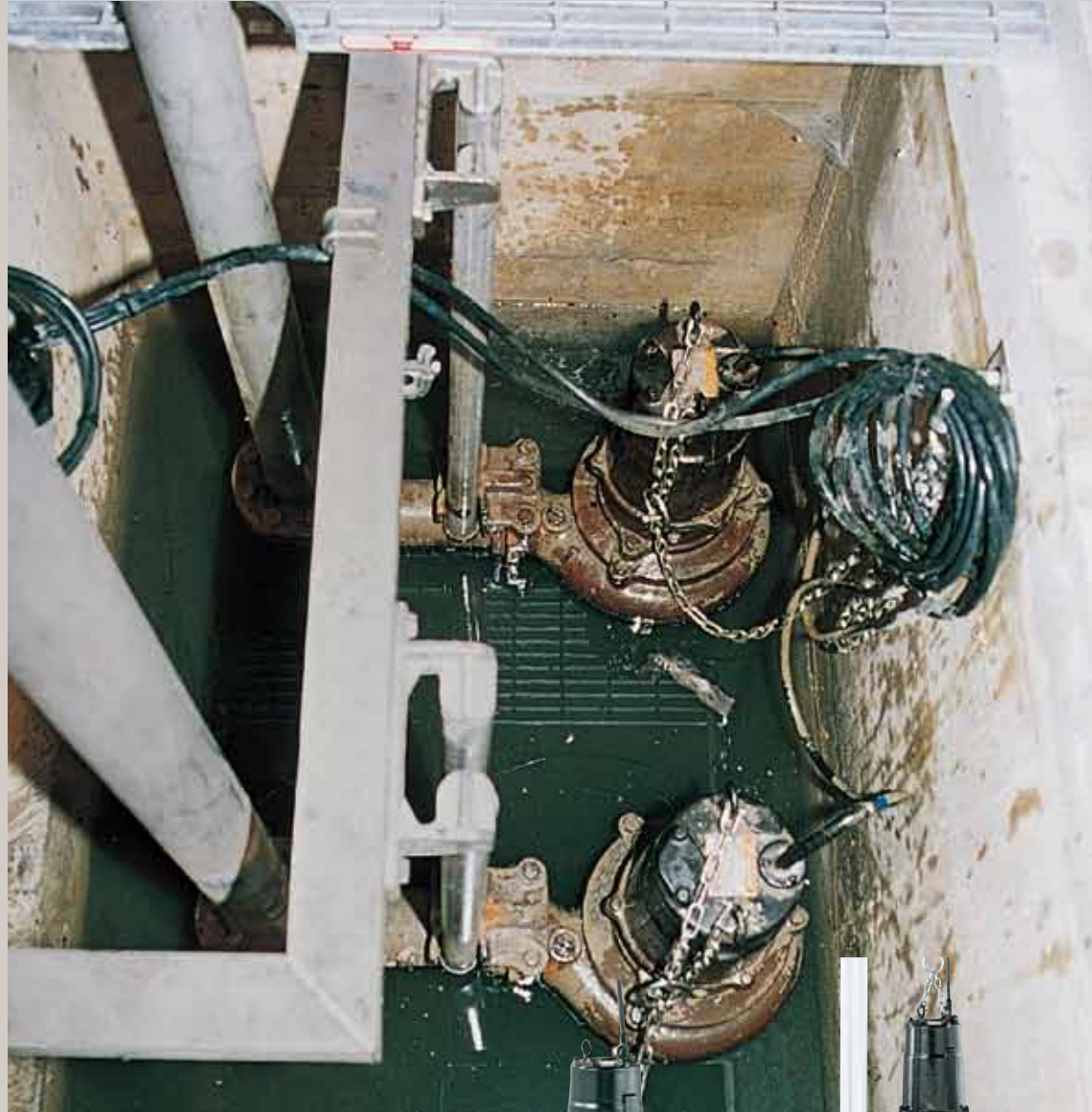

Submersible Sewage Pumps

Channel Impeller

BZ



A specially designed single channel impeller makes the BZ pump possible to pass 80mm diameter solids.

Cable Entry

Every cable has an anti-wicking block at the cable entry section of the pump. This mechanism is such that a part of each conductor is stripped back and the part is sealed by molded rubber or epoxy potting which has flowed in between each strand of the conductor. This unique feature prevents wicking along the strand of the conductor itself.

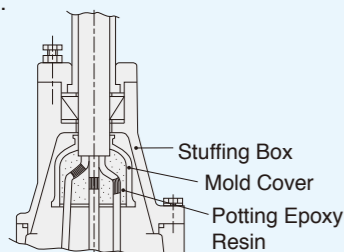

Motor Protector

A Miniature Thermal Protector (MTP) is embedded in each winding of the motor. These MTPs are connected in series, and their wires are led out of the motor. Should the winding temperature rise to the actuating temperature, the bimetal strip opens to cause the control panel to shut the power supply.

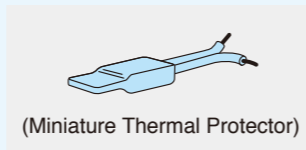

Mechanical Seal

The mechanical seal with two seal faces containing silicon carbide (SiC) is equipped with the oil chamber. The advantages of the seal are two-fold, it eliminates spring failure caused by corrosion, abrasion or fouling which prevents the seal faces from closing properly, and prevents loss of cooling to the lower seal faces during run-dry conditions which causes the lower seal faces to fail.

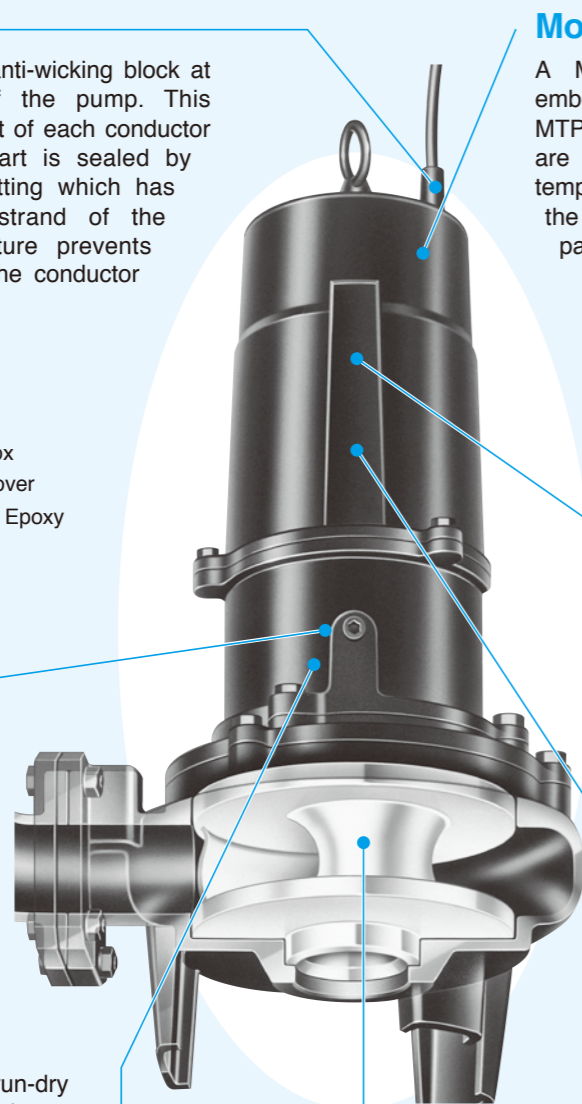

Motor

The motor is dry-type, squirrel-cage induction motor, housed in a cast iron watertight casing, and conforms to insulation class of F. All standard pumps can be used under the maximum ambient temperature of 40°C.

Shaft

The high-tensile stainless steel shaft used on all pumps is designed to have adequate strength for the transmission of the full load. It is supported by C3 type, high-quality, deep-groove ball bearings.

Impeller

The BZ pump is equipped with a specially designed single channel impeller. It is designed to have a wide passage from the inlet to outlet and enables it to pass solids with 80mm in diameter. This ensures waste water and sewage are transferred without clogging.



Back Pullout Design

Unfastening the bolts between the oil casing and the pump casing allows the body to be separated into the pump section and the motor section with the impeller left in position. This facilitates inspections of the main portions. (Applied to pumps up to 3.7kW)



Oil Lifter (Patented)

The Oil Lifter was developed as a lubricating device for the mechanical seal. Utilizing the centrifugal force of the shaft seal, the Oil Lifter forcibly supplies lubricating oil to the mechanical seal and continues to supply the oil to the upper seal faces even if lubricant falls below the rated volume. This amazingly simple device is not only reliably lubricates and cools down, but also retains the stable shaft seal effect and extends the inspection term.

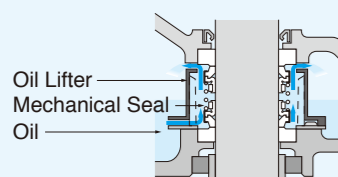

MODEL NUMBER DESIGNATION

100	BZ	4	11	H
Discharge bore in millimeters		Sub code for the pumping head		
Name of the series		H : High head Blank : Standard		
Number of motor poles		Rated motor output in kilowatts		

Performance Curves

DISCHARGE BORE 80mm·100mm

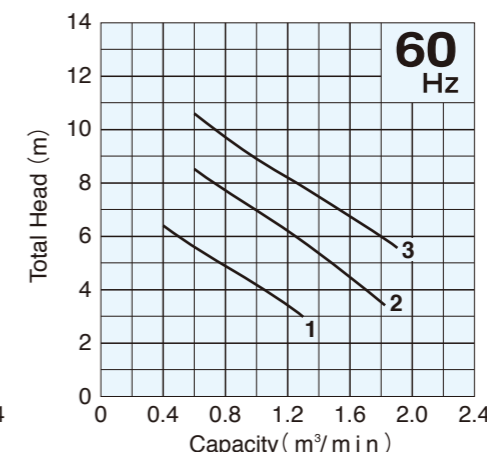
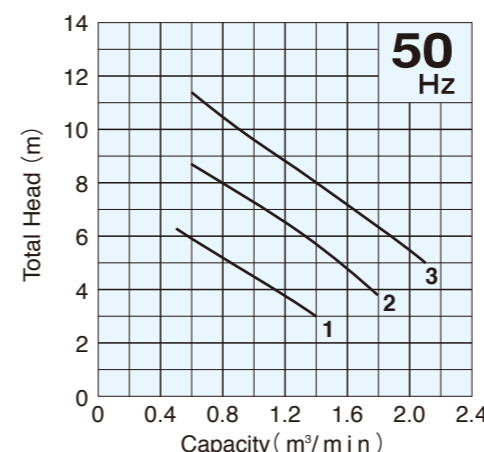

DISCHARGE BORE 100mm

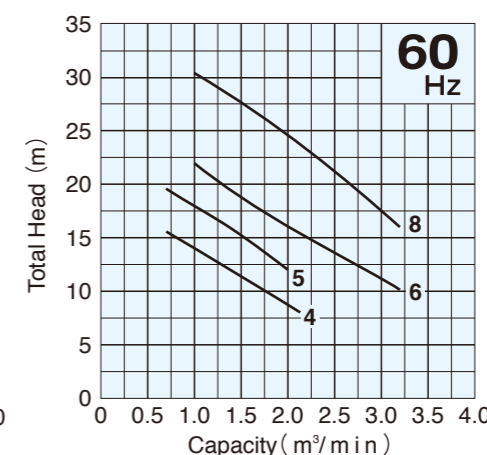
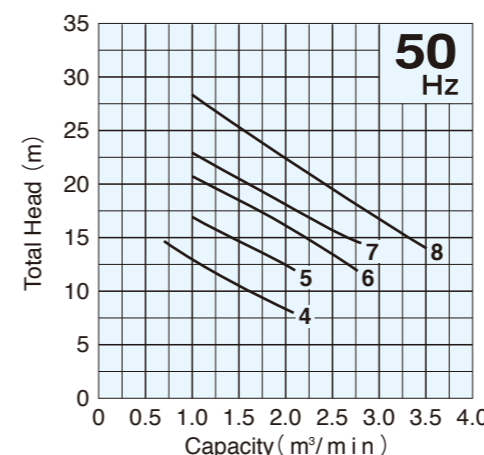

Dimensions

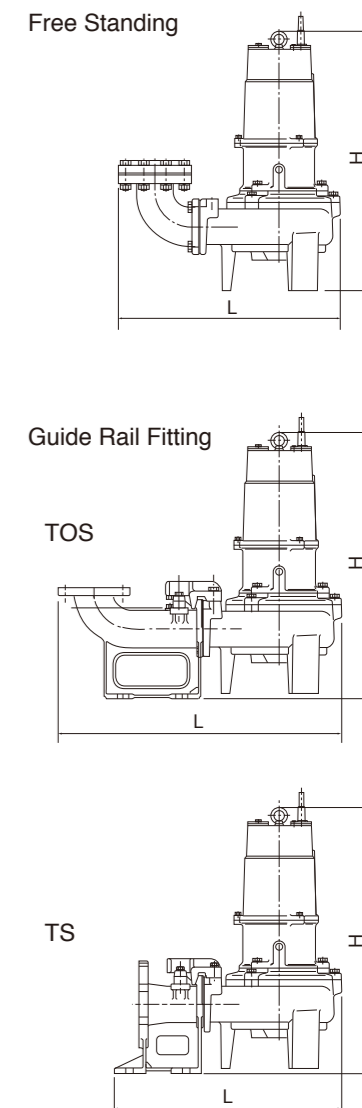

Model Selection

Curve No.	Discharge Bore mm	Model			Motor Output kW	Speed (S.S.) 50Hz/60Hz min ⁻¹	Starting Method	Solids Passage mm	Cable Length m	Cable Code	Dimensions 50Hz/60Hz L×H mm			Dry Weight* ³ kg	
		Free Standing	Guide Rail Fitting								Free Standing	Guide Rail Fitting	Free	Fitting	
			TOS	TS											Standing
1	80	80BZ41.5	TOS80BZ41.5	TS80BZ41.5	1.5	1500/1800	D.O.L.	80	10	B	523×631	697×646	544×646	78	74
2	100	100BZ42.2	TOS100BZ42.2	TS100BZ42.2	2.2	1500/1800	D.O.L.	80	10	B(D* ²)	551×631	709×646	554×646	78	74
3	100	100BZ43.7	TOS100BZ43.7	TS100BZ43.7	3.7	1500/1800	D.O.L.	80	10	D(E* ²)	584×681	743×696	588×696	98	94
4	100	100BZ45.5	TOS100BZ45.5	TS100BZ45.5	5.5	1500/1800	D.O.L.	80	10	G	716×925	935×914	740×914	149	144
5	100	100BZ47.5	TOS100BZ47.5	TS100BZ47.5	7.5	1500/1800	D.O.L.	80	10	W	716×946	935×935	740×935	165	160
6	100	100BZ411	TOS100BZ411	TS100BZ411	11	1500/1800	Star-Delta	80	10	L	727×1023	946×1016	751×1016	222	217
7* ¹	100	100BZ411H	TOS100BZ411H	TS100BZ411H	11	1500/—	Star-Delta	80	10	L	727×1023	946×1016	751×1016	222	217
8	100	100BZ415	TOS100BZ415	—	15	1500/1800	Star-Delta	80	10	M	845×1160/ 770×1088	1044×1174/ 989×1076	—	295	290

Note : Every model operates on a three phase supply.

*¹ 50Hz only

*² 200~240V

*³ All weights excluding cable

Weights of guide rail fitting model excluding duckfoot bend

CABTYRE CABLE CODE REFERENCE

Code	Pieces per Unit	Cores×mm ²	Dia. mm	Material
B	2	4×1.25 4×1.25	11.1 11.1	PVC
D	2	4×2 4×1.25	11.8 11.1	
E	2	4×3.5 4×1.25	13.9 11.1	

Code	Pieces per Unit	Cores×mm ²	Dia. mm	Material
G	2	4×3.5 2×1.25	14.1 9.8	Chloroprene Rubber
L	3	4×3.5 3×3.5 2×1.25	14.1 12.9 9.8	
M	3	4×5.5 3×5.5 2×1.25	16.8 15.2 9.8	
W	2	4×5.5 2×1.25	16.8 9.8	

GUIDE RAIL FITTING SYSTEM

TOS

TOS is the Tsurumi standard guide rail fitting system. This system connects the pump to and from the piping easily just by lowering and hoisting the pump, allowing easy maintenance and inspection without the need to enter the sump.

TS

This compact guide rail fitting system is ideal for installing in prefabricated lift stations. Its discharge flange is compatible with major flange standards including ANSI 150lb, BS PN10, and DIN PN10.



TSURUMI OPTIONS

SPECIAL VERSION WITH GALVANIC CORROSION PROTECTION

In seawater, the effect of galvanic corrosion is more serious than that of ordinary corrosion. When two kinds of metals are dipped into an electrolytic liquid, a battery phenomenon occurs due to the difference in the electric potential of the two materials. In this case, the metal having higher potential corrodes first. As an option, Tsurumi can supply the pumps as an option, with parts made of higher electric potential metal as sacrificial anodes.

SPECIAL VERSION FOR HIGHER TEMPERATURE LIQUID

Standard pumps are designed for continuous running at a maximum ambient temperature of 40°C. In addition to these, Tsurumi can provide pumps for operation at higher liquid temperature upon request. Refitting for operation at higher temperature involves modification of not only the insulation of motor windings but also several components. The high-temperature operation models are available for the RANK 60 version, for the operation in liquids up to 60°C. Consult your dealer for more details. (These special versions are not available for some pump models.)

DRY PIT VERSION

The advantage of the dry pit type pump is that a flooding of water will not damage it, as it is constructed by a submersible pump. Tsurumi can provide the dry pit type pumps as an option for the whole range of BZ-series pumps. Durable motor with effective water-cooling jacket assures the pump continuous running without overheating.

SPECIAL VERSION WITH NON-STANDARD MATERIALS

Tsurumi can also provide you with pumps with essential components such as the impeller, pump casing, and the suction cover made of non-standard materials. Select from stainless steel, chromium iron, and bronze to suit your specific requirements. Consult your dealer for more details.

We reserve the right to change the specifications and designs for improvement without prior notice.

TSURUMI
MANUFACTURING CO., LTD.

Your Dealer

Chainaris Phuket Engineering Co., Ltd.
63/13 Moo.2, T.Vichit, A.Muang Phuket 83000
Tel. 076-513100-3 Fax. 076-513105
www.chainaris.co.th

