



# Quick Guide

## VLT<sup>®</sup> AutomationDrive FC 360





## Contents

<b>1 Introduction</b>	<b>3</b>
1.1 Purpose of the Manual	3
1.2 Additional Resources	3
1.3 Document and Software Version	3
1.4 Approvals and Certifications	3
1.5 Disposal	3
1.6 Product Overview	3
<b>2 Safety</b>	<b>7</b>
2.1 Safety Symbols	7
2.2 Qualified Personnel	7
2.3 Safety Precautions	7
<b>3 Quick Start</b>	<b>9</b>
3.1 Identification and Variants	9
3.2 Hand On/Auto On Mode	10
3.3 Application Selections	10
3.4 Jumper Terminal 12 and 27	14
3.5 Automatic Motor Adaptation (AMA)	14
<b>4 Installation</b>	<b>15</b>
4.1 Mechanical Installation	15
4.2 Electrical Installation	16
4.3 Serial Communication	22
<b>5 Local Control Panel and Programming</b>	<b>23</b>
5.1 Local Control Panel (LCP) Operations	23
5.2 Main Menu	25
5.3 Quick Menu	27
5.4 PM Motor Set-up	29
5.5 PROFIBUS	31
5.6 PROFINET	32
5.7 Parameter List	33
<b>6 Application Examples</b>	<b>39</b>
<b>7 Diagnostics and Troubleshooting</b>	<b>43</b>
7.1 Warning and Alarm Types	43
7.2 Warning and Alarm Displays	43
7.3 Warning and Alarm Code List	44
7.4 Error Code List	46

---

7.5 Troubleshooting	46
<b>8 Specifications</b>	<b>48</b>
8.1 Mains Supply 3x380–480 V AC	48
8.2 General Technical Data	51
8.3 Fuses	55
8.4 Connection Tightening Torques	56
<b>Index</b>	<b>57</b>

# 1 Introduction

## 1.1 Purpose of the Manual

The quick guide provides information for safe installation and commissioning of the frequency converter.

The quick guide is intended for use by qualified personnel. Read and follow the quick guide to use the frequency converter safely and professionally, and pay particular attention to the safety instructions and general warnings. Always keep this quick guide available with the frequency converter.

VLT® is a registered trademark.

## 1.2 Additional Resources

Other resources are available to understand advanced frequency converter functions and programming.

- The *programming guide* provides greater detail on working with parameters.
- The *design guide* provides detailed capabilities and functionality to design motor control systems.
- Optional equipment is available that may change some of the procedures described. Be sure to see the instructions supplied with those options for specific requirements.

Contact the local Danfoss supplier for technical documents.

## 1.3 Document and Software Version

The quick guide is regularly reviewed and updated. All suggestions for improvement are welcome.

Edition	Remarks	Software version
MG06A6xx	Replaces MG06A5xx	1.5x

## 1.4 Approvals and Certifications



Illustration 1.1 Approval

## 1.5 Disposal

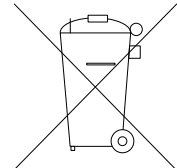

Do not dispose of equipment containing electrical components together with domestic waste. Collect it separately in accordance with local and currently valid legislation.

## 1.6 Product Overview

A frequency converter is an electronic motor controller that converts AC mains input into a variable AC waveform output. The frequency and voltage of the output are regulated to control the motor speed or torque. The frequency converter can vary the speed of the motor in response to system feedback, such as changing temperature or pressure for controlling fan, compressor, or pump motors. The frequency converter can also regulate the motor by responding to remote commands from external controllers.

In addition, the frequency converter monitors the system and motor status, issues warnings or alarms for fault conditions, starts and stops the motor, optimises energy efficiency, and offers many more control, monitoring, and efficiency functions. Operation and monitoring functions are available as status indications to an outside control system or serial communication network.

1.6.1 Enclosure Types and Power Ratings

Enclosure size 380–480 V	J1	J2	J3	J4	J5	J6	J7
Power size [kW]	0.37–2.2	3.0–5.5	7.5	11–15	18.5–22	30–45	55–75
Dimensions [mm]							
Height A	210	272.5	272.5	317.5	410	515	550
Width B	75	90	115	133	150	233	308
Depth C (with option B)	168 (173)	168 (173)	168 (173)	245 (250)	245 (250)	241	323
<b>Mounting holes</b>							
a	198	260	260	297.5	390	495	521
b	60	70	90	105	120	200	270
Mounting screw	M4	M5	M5	M6	M6	M8	M8

Table 1.1 Enclosure Sizes, Power Ratings, and Dimensions

1.6.2 Exploded Views

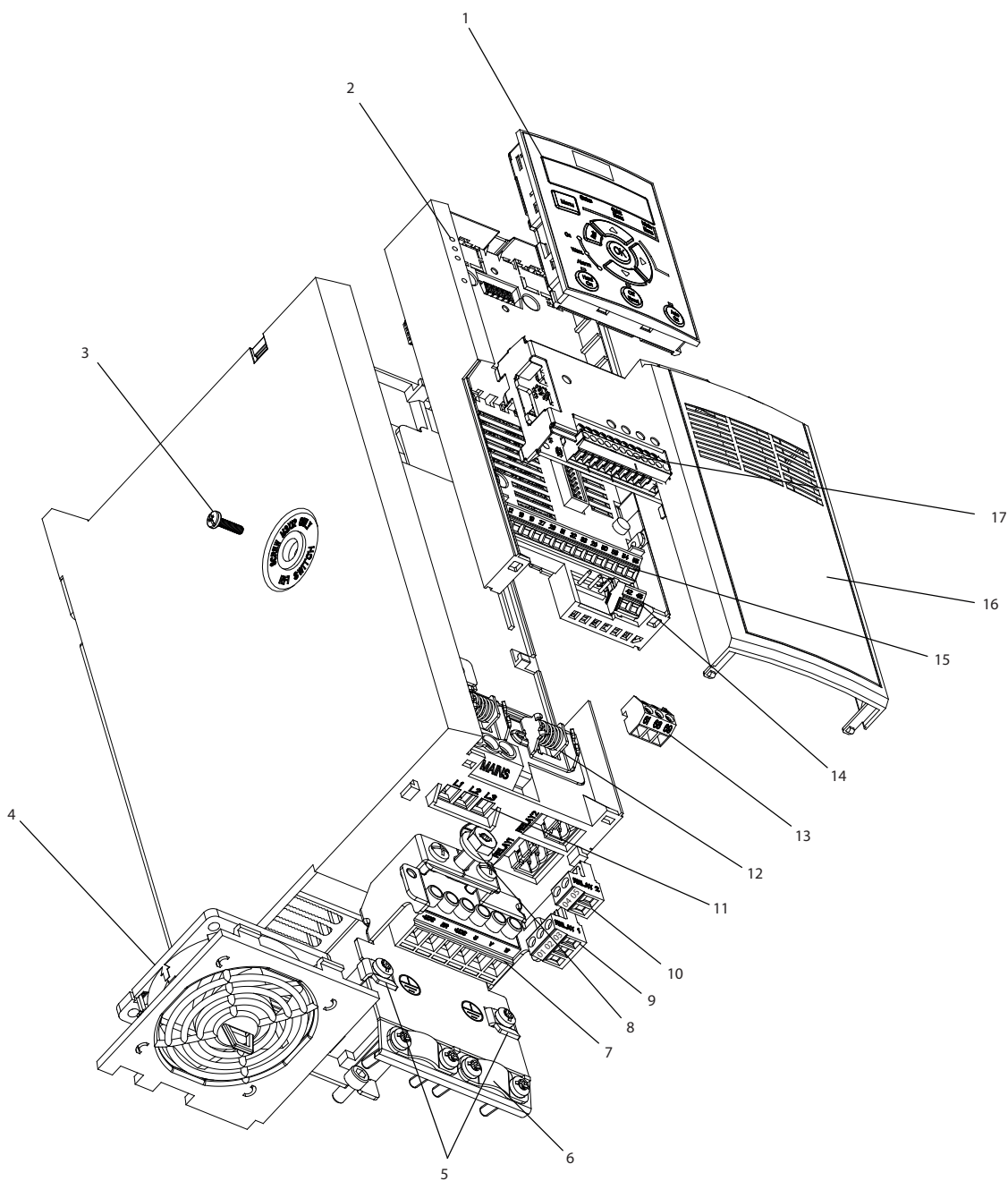

130BC439.10

1	NLCP (accessory)	10	2-pole relay 2 (0.37–7.5 kW), pluggable 3-pole relay 2 (11–22 kW), pluggable
2	Control cassette	11	Mains terminals
3	RFI switch (screw M3x12 only)	12	Cable strain relief (accessory for 0.37–2.2 kW units)
4	Removable fan assembly	13	Pluggable RS485 terminal
5	Grounding clamp (accessory)	14	Fixed I/O terminals
6	Screened cable grounding clamp and strain relief (accessory)	15	Fixed I/O terminals
7	Motor terminals (U, V, W), and brake and load sharing terminals	16	Terminal cover
8	PE ground	17	B options (MCB 102/MCB 103 accessories)
9	3-pole relay 1		

Illustration 1.2 Exploded View, J1–J5 (0.37–22 kW), IP20

1

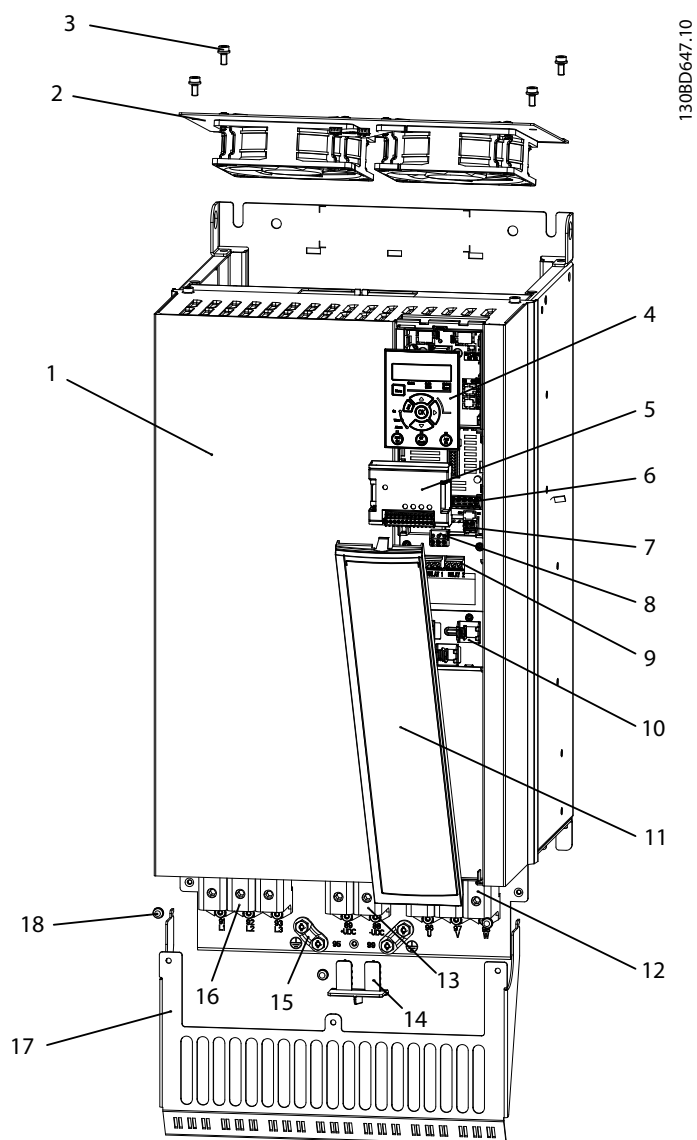

1	J7 frequency converter	10	I/O cable clamps
2	Removable fan assembly	11	Terminal cover
3	M5 screw X4 (for fan assembly)	12	Motor terminals
4	NLCP (accessory)	13	Load sharing terminals
5	B options (MCB 102/MCB 103 accessories)	14	Removable plugger (for load sharing terminal)
6	I/O terminals	15	Screened cable grounding clamps
7	I/O terminals	16	Mains terminals
8	Pluggable RS485 terminals	17	Decoupling plate (accessory)
9	Relay terminal 1&2, fixed	18	M4 screw X3 (for decoupling plate)

Illustration 1.3 Exploded View, J7 (55 kW, 75 kW), IP20



## 2 Safety

### 2.1 Safety Symbols

The following symbols are used in this document:



Indicates a potentially hazardous situation that could result in death or serious injury.



Indicates a potentially hazardous situation that could result in minor or moderate injury. It can also be used to alert against unsafe practices.

#### NOTICE

Indicates important information, including situations that can result in damage to equipment or property.

### 2.2 Qualified Personnel

Correct and reliable transport, storage, installation, operation, and maintenance are required for the trouble-free and safe operation of the frequency converter. Only qualified personnel are allowed to install or operate this equipment.

Qualified personnel are defined as trained staff, who are authorised to install, commission, and maintain equipment, systems, and circuits in accordance with pertinent laws and regulations. Additionally, the personnel must be familiar with the instructions and safety measures described in this manual.

### 2.3 Safety Precautions



#### HIGH VOLTAGE

Frequency converters contain high voltage when connected to AC mains input, DC supply, or load sharing. Failure to perform installation, start-up, and maintenance by qualified personnel can result in death or serious injury.

- Only qualified personnel must perform installation, start-up, and maintenance.



#### UNINTENDED START

When the frequency converter is connected to AC mains, DC supply, or load sharing, the motor may start at any time. Unintended start during programming, service, or repair work can result in death, serious injury, or property damage. Start the motor with an external switch, a fieldbus command, an input reference signal from the local control panel (LCP), via remote operation using MCT 10 software, or after a cleared fault condition. To prevent unintended motor start:

- Disconnect the frequency converter from the mains.
- Press [Off/Reset] on the LCP before programming parameters.
- Ensure that the frequency converter is fully wired and assembled when it is connected to AC mains, DC supply, or load sharing.



#### DISCHARGE TIME

The frequency converter contains DC-link capacitors, which can remain charged even when the frequency converter is not powered. Failure to wait the specified time after power has been removed before performing service or repair work, could result in death or serious injury.

1. Stop the motor.
2. Disconnect AC mains, permanent magnet type motors, and remote DC-link power supplies, including battery back-ups, UPS, and DC-link connections to other frequency converters.
3. Wait for the capacitors to discharge fully, before performing any service or repair work. The duration of waiting time is specified in *Table 2.1*.

Voltage [V]	Minimum waiting time (minutes)	
	4	15
380–480	0.37–7.5 kW	11–75 kW
High voltage may be present even when the warning LEDs are off.		

Table 2.1 Discharge Time

**⚠ WARNING****LEAKAGE CURRENT HAZARD**

Leakage currents exceed 3.5 mA. Failure to ground the frequency converter properly can result in death or serious injury.

- Ensure the correct grounding of the equipment by a certified electrical installer.

**⚠ WARNING****EQUIPMENT HAZARD**

Contact with rotating shafts and electrical equipment can result in death or serious injury.

- Ensure that only trained and qualified personnel perform installation, start-up, and maintenance.
- Ensure that electrical work conforms to national and local electrical codes.
- Follow the procedures in this manual.

**NOTICE****HIGH ALTITUDES**

For installation at altitudes above 2000 m, contact Danfoss regarding PELV.

**⚠ CAUTION****INTERNAL FAILURE HAZARD**

An internal failure in the frequency converter can result in serious injury, when the frequency converter is not properly closed.

- Ensure that all safety covers are in place and securely fastened before applying power.

**NOTICE****Use on Isolated Mains**

For details about the use of the frequency converter on isolated mains, refer to section *RFI Switch* in the *design guide*.

Follow the recommendations regarding the installation on IT-mains. Use relevant monitoring devices for IT-mains to avoid damage.

### 3 Quick Start

#### **⚠️ WARNING**

Improper use could result in death, serious injury, equipment, or property damage. Before installing or using the equipment, carefully read *chapter 2 Safety* and *chapter 4 Installation*.

#### 3.1 Identification and Variants

Confirm that the equipment matches the requirements and ordering information by checking power size, voltage data, and overload data on the nameplate of the frequency converter.

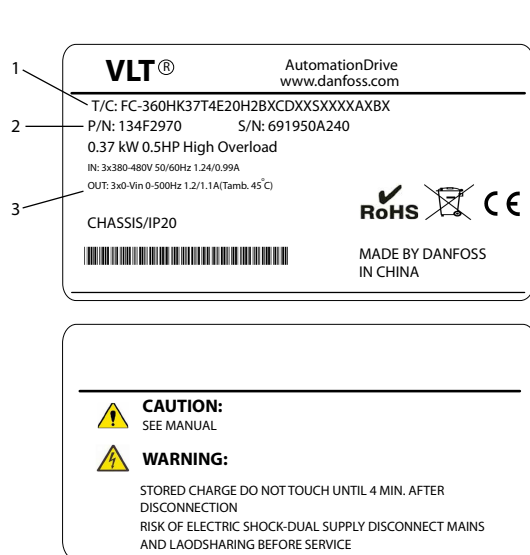

1	Type code
2	Ordering number
3	Specifications

Illustration 3.1 Nameplate 1 and 2

1–6: Product Name	
7: Overload	H: Heavy duty Q: Normal duty <sup>1)</sup>
8–10: Power size	0.37–75 kW. For example: K37: 0.37 kW <sup>2)</sup> 1K1: 1.1 kW 11K: 11 kW
11–12: Voltage class	T4: 380–480 V 3-phases
13–15: IP class	E20: IP20
16–17: RFI	H2: C3 Class
18: Brake chopper	X: No B: Built-in <sup>3)</sup>
19: LCP	X: No
20: PCB coating	C: 3C3
21: Mains terminals	D: Load sharing
29–30: Embedded fieldbus	AX: No A0: PROFIBUS AL: PROFINET

Table 3.1 Type Code: Selection of Different Features and Options

For options and accessories, refer to the section *Options and Accessories in the FC 360 Design Guide*.

1) Only 11–75 kW for normal duty variants. PROFIBUS and PROFINET unavailable for normal duty.

2) For all power sizes, see chapter 8.1.1 *Mains Supply 3x380–480 V AC*.

3) 0.37–22 kW with built-in brake chopper. 30–75 kW with external brake chopper only.

1	2	3	4	5	6	7	8	9	10	11	12	13	14	15	16	17	18	19	20	21	22	23	24	25	26	27	28	29	30	31	32
F	C	-	3	6	0	H				T	4	E	2	0	H	2	X	X	C	D	X	X	S	X	X	X	X	A	X	B	X
						Q											B											A	0		
																												A	L		

Illustration 3.2 Type Code String

3

### 3.2 Hand On/Auto On Mode

After installation (see *chapter 4 Installation*), there are 2 simple ways to start up the frequency converter: Hand On and Auto On mode. At the first power-up, it is in Auto On mode.

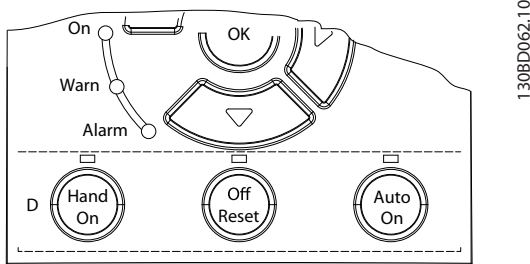

Illustration 3.3 Location of Hand On, Off/Reset and Auto On Keys on the NLCP

- Press [Hand On] to provide a local start command to the frequency converter. Press [▲] and [▼] to increase and decrease speed.
- Press [Off/Reset] to stop the frequency converter.
- Press [Auto On] to control the frequency converter either via control terminals or serial communication.

### CAUTION

Since the frequency converter is in Auto On mode at first power-up, the frequency converter may start the motor directly.

### NOTICE

Parameter 5-12 Terminal 27 Digital Input has coast inverse as default setting. Connect terminals 12 and 27 to test Hand On/Auto On running.

For LCP operation, see *chapter 5 Local Control Panel and Programming*.

### 3.3 Application Selections

Use the selections for quick application set-up of the most common applications by setting *parameter 0-16 Application Selection*. When necessary, the selections can be modified for individual needs. All selections are for Auto On mode.

### NOTICE

When an application is selected, relevant parameters are automatically set. Customer-specific configuration of all parameters based on specific requirements is still possible.

### NOTICE

If any of the applications are selected, relay 1 is set to [Running] and relay 2 is set to [Alarm]

<b>Application</b>																																													
Pumps, fans, compressors																																													
<b>Description</b>																																													
For applications where a value (for example, pressure, temperature) must be kept at a desired level by sensor feedback																																													
<table border="1"> <tr><td>FC 360</td><td></td></tr> <tr><td>+24V</td><td>12</td></tr> <tr><td>DI1</td><td>18</td></tr> <tr><td>DI2</td><td>19</td></tr> <tr><td>DI3</td><td>27</td></tr> <tr><td>DI4</td><td>29</td></tr> <tr><td>DI5</td><td>32</td></tr> <tr><td>DI6</td><td>33</td></tr> <tr><td>DI7</td><td>31</td></tr> <tr><td>COM</td><td>20</td></tr> <tr><td>+10V</td><td>50</td></tr> <tr><td>AI1</td><td>53</td></tr> <tr><td>AI2</td><td>54</td></tr> <tr><td>COM</td><td>55</td></tr> <tr><td>AO1</td><td>45</td></tr> <tr><td>AO2</td><td>42</td></tr> <tr><td></td><td>1</td></tr> <tr><td>R1</td><td>2</td></tr> <tr><td></td><td>3</td></tr> <tr><td></td><td>4</td></tr> <tr><td>R2</td><td>5</td></tr> <tr><td></td><td>6</td></tr> </table>	FC 360		+24V	12	DI1	18	DI2	19	DI3	27	DI4	29	DI5	32	DI6	33	DI7	31	COM	20	+10V	50	AI1	53	AI2	54	COM	55	AO1	45	AO2	42		1	R1	2		3		4	R2	5		6	
FC 360																																													
+24V	12																																												
DI1	18																																												
DI2	19																																												
DI3	27																																												
DI4	29																																												
DI5	32																																												
DI6	33																																												
DI7	31																																												
COM	20																																												
+10V	50																																												
AI1	53																																												
AI2	54																																												
COM	55																																												
AO1	45																																												
AO2	42																																												
	1																																												
R1	2																																												
	3																																												
	4																																												
R2	5																																												
	6																																												
<b>Parameter settings</b>																																													
<b>Parameter</b>	<b>Option/value</b>																																												
Parameter 1-00 Configuration Mode	[3] Process Closed Loop																																												
Parameter 1-03 Torque Characteristics	[1] Variable Torque																																												
Parameter 3-00 Reference Range	[0] Min- Max																																												
Parameter 3-15 Reference 1 Source	[0] No Function																																												
Parameter 4-12 Motor Speed Low Limit [Hz]	30.0 Hz																																												
Parameter 4-14 Motor Speed High Limit [Hz]	50.0 Hz																																												
Parameter 5-10 Terminal 18 Digital Input	[8] Start																																												
Parameter 5-12 Terminal 27 Digital Input	[2] Coast Inverse																																												
Parameter 5-14 Terminal 32 Digital Input	[14] Jog																																												
Parameter 5-40 Function Relay (Relay 1 Selection)	[5] Running																																												
Parameter 5-40 Function Relay (Relay 2 Selection)	[9] Alarm																																												
Parameter 6-22 Terminal 54 Low Current	4.0 mA																																												
Parameter 6-23 Terminal 54 High Current	20.0 mA																																												
Parameter 6-29 Terminal 54 mode	[0] Current Mode																																												
Parameter 6-70 Terminal 45 Mode	[0] 0-20 mA																																												

Parameter 6-71 Terminal 45 Analog Output	[100] Output frequency
Parameter 6-90 Terminal 42 Mode	[0] 0–20 mA
Parameter 6-91 Terminal 42 Analog Output	[103] Motor Current
Parameter 7-20 Process CL Feedback 1 Resource	[2] Analog input 54

Table 3.2 Process Closed Loop

<b>Application</b>		
Local/remote		
<b>Description</b>		
For applications where the speed reference can be switched between local potentiometer and remote current signal		
<b>Parameter settings</b>	<b>Set-up 1</b>	<b>Set-up 2</b>
Parameter 0-10 Active Set-up	[9] Multi Set-up	[9] Multi Set-up
Parameter 0-12 Link Setups	[20] Linked	[20] Linked
Parameter 1-00 Configuration Mode	[0] Speed Open Loop	[0] Speed Open Loop
Parameter 3-00 Reference Range	[0] Min–Max	[0] Min–Max
Parameter 3-15 Reference 1 Source	[1] AI 53	[2] AI 54
Parameter 3-16 Reference 2 Source		
Parameter 4-12 Motor Speed Low Limit [Hz]	25.0 Hz	25.0 Hz
Parameter 4-14 Motor Speed High Limit [Hz]	50.0 Hz	50.0 Hz
Parameter 5-10 Terminal 18 Digital Input	[8] Start	[8] Start

Parameter 5-12 Terminal 27 Digital Input	[2] Coast Inverse	[2] Coast Inverse
Parameter 5-14 Terminal 32 Digital Input	[23] Set-up select	[23] Set-up select
Parameter 5-40 Function Relay (Relay 1 Selection)	[5] Running	[5] Running
Parameter 5-40 Function Relay (Relay 2 Selection)	[9] Alarm	[9] Alarm
Parameter 6-10 Terminal 53 Low Voltage	0.07 V	
Parameter 6-11 Terminal 53 High Voltage	10 V	
Parameter 6-19 Terminal 53 mode	[1] Voltage Mode	
Parameter 6-22 Terminal 54 Low Current		4.0 mA
Parameter 6-23 Terminal 54 High Current		20.0 mA
Parameter 6-29 Terminal 54 mode		[0] Current Mode
Parameter 6-70 Terminal 45 Mode	[0] 0–20 mA	[0] 0–20 mA
Parameter 6-71 Terminal 45 Analog Output	[100] Output frequency	[100] Output frequency
Parameter 6-90 Terminal 42 Mode	[0] 0–20 mA	[0] 0–20 mA
Parameter 6-91 Terminal 42 Analog Output	[103] Motor Current	[103] Motor Current

Table 3.3 Local/Remote

Application	
Conveyors, extruders	
Description	
For running at a stable speed by a voltage reference signal.	
Parameter settings	
Parameter	Option/value
Parameter 1-00 Configuration Mode	[0] Speed Open Loop
Parameter 3-00 Reference Range	[0] Min–Max
Parameter 3-15 Reference 1 Source	[1] AI 53
Parameter 4-12 Motor Speed Low Limit [Hz]	25.0 Hz
Parameter 4-14 Motor Speed High Limit [Hz]	50.0 Hz
Parameter 5-10 Terminal 18 Digital Input	[8] Start
Parameter 5-12 Terminal 27 Digital Input	[2] Coast Inverse
Parameter 5-40 Function Relay (Relay 1 Selection)	[5] Running
Parameter 5-40 Function Relay (Relay 2 Selection)	[9] Alarm
Parameter 6-10 Terminal 53 Low Voltage	0.07 V
Parameter 6-11 Terminal 53 High Voltage	10 V
Parameter 6-19 Terminal 53 mode	[1] Voltage Mode
Parameter 6-70 Terminal 45 Mode	[0] 0–20 mA
Parameter 6-71 Terminal 45 Analog Output	[100] Output frequency
Parameter 6-90 Terminal 42 Mode	[0] 0–20 mA
Parameter 6-91 Terminal 42 Analog Output	[103] Motor Current

Table 3.4 Speed Open Loop

Application	
Machine tools, texturizers	
Description	
For precise speed applications with 24 V encoder feedback	
Parameter settings	
Parameter	Option/value
Parameter 1-00 Configuration Mode	[1] Speed Close Loop
Parameter 3-00 Reference Range	[0] Min–Max
Parameter 3-15 Reference 1 Source	[1] AI 53
Parameter 3-16 Reference 2 Source	[11] Local Bus Ref
Parameter 4-12 Motor Speed Low Limit [Hz]	20.0 Hz
Parameter 4-14 Motor Speed High Limit [Hz]	50.0 Hz
Parameter 5-10 Terminal 18 Digital Input	[8] Start
Parameter 5-12 Terminal 27 Digital Input	[2] Coast Inverse
Parameter 5-14 Terminal 32 Digital Input	[82] Encoder input B
Parameter 5-15 Terminal 33 Digital Input	[81] Encoder input A
Parameter 5-40 Function Relay (Relay 1 Selection)	[5] Running
Parameter 5-40 Function Relay (Relay 2 Selection)	[9] Alarm
Parameter 6-10 Terminal 53 Low Voltage	0.07 V
Parameter 6-11 Terminal 53 High Voltage	10 V
Parameter 6-19 Terminal 53 mode	[1] Voltage Mode
Parameter 6-70 Terminal 45 Mode	[0] 0–20 mA
Parameter 6-71 Terminal 45 Analog Output	[100] Output frequency
Parameter 6-90 Terminal 42 Mode	[0] 0–20 mA
Parameter 6-91 Terminal 42 Analog Output	[103] Motor Current

Parameter 7-00 Speed PID Feedback Source	[1] 24 V encoder
--	------------------

Table 3.5 Speed Close Loop

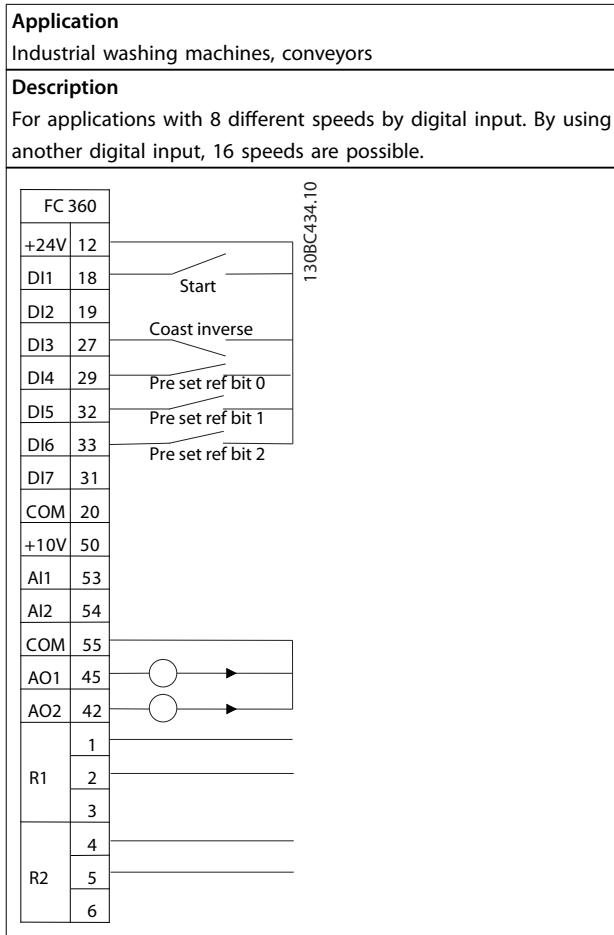

**Parameter settings**

Parameter	Option/value
Parameter 1-00 Configuration Mode	[0] Speed Open Loop
Parameter 3-00 Reference Range	[0] Min–Max
Parameter 3-15 Reference 1 Source	[0] No Function
Parameter 4-14 Motor Speed High Limit [Hz]	50.0 Hz
Parameter 5-10 Terminal 18 Digital Input	[8] Start
Parameter 5-12 Terminal 27 Digital Input	[2] Coast Inverse
Parameter 5-13 Terminal 29 Digital Input	[16] Preset ref bit 0
Parameter 5-14 Terminal 32 Digital Input	[17] Preset ref bit 1
Parameter 5-15 Terminal 33 Digital Input	[18] Preset ref bit 2
Parameter 6-70 Terminal 45 Mode	[0] 0–20 mA
Parameter 6-71 Terminal 45 Analog Output	[100] Output frequency
Parameter 6-90 Terminal 42 Mode	[0] 0–20 mA
Parameter 6-91 Terminal 42 Analog Output	[103] Motor Current

Table 3.6 Multi-speed

**Application**  
One Gear Drive (OGD)

**Description**  
For applications that use OGD. For example, conveyors in food and beverage industries.

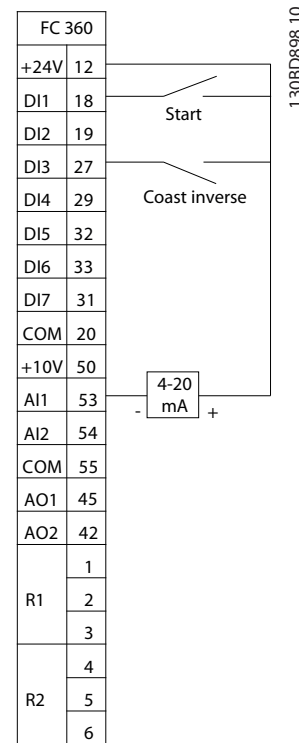

**Parameter settings**

Parameter	Option/value
Parameter 1-00 Configuration Mode	[0] Open Loop
Parameter 1-01 Motor Control Principle	[1] VVC+
Parameter 1-08 Motor Control Bandwidth	high
Parameter 1-10 Motor Construction	[1] PM, non-salient SPM
Parameter 1-14 Damping Gain	120
Parameter 1-15 Low Speed Filter Time Const.	0.175
Parameter 1-16 High Speed Filter Time Const.	0.175
Parameter 1-17 Voltage filter time const.	0.035
Parameter 1-24 Motor Current	7.2
Parameter 1-25 Motor Nominal Speed	3000
Parameter 1-26 Motor Cont. Rated Torque	12.6
Parameter 1-29 Automatic Motor Adaptation (AMA)	[0] Off
Parameter 1-30 Stator Resistance (Rs)	0.5
Parameter 1-37 d-axis Inductance (Ld)	5
Parameter 1-39 Motor Poles	10
Parameter 1-40 Back EMF at 1000 RPM	120
Parameter 1-42 Motor Cable Length	50 m
Parameter 1-66 Min. Current at Low Speed	50
Parameter 1-73 Flying Start	[2] Enable always
Parameter 2-06 Parking Current	80
Parameter 2-07 Parking Time	0.5

Parameter 2-10 Brake Function	[0] Off
Parameter 3-03 Maximum Reference	250 Hz
Parameter 4-14 Motor Speed High Limit [Hz]	250 Hz
Parameter 4-16 Torque Limit Motor Mode	160
Parameter 4-18 Current Limit	160
Parameter 5-10 Terminal 18 Digital Input	[8] Start
Parameter 5-11 Terminal 19 Digital Input	[0] No operation
Parameter 5-12 Terminal 27 Digital Input	[2] Coast inverse
Parameter 5-13 Terminal 29 Digital Input	[0] No operation
Parameter 5-14 Terminal 32 Digital Input	[0] No operation
Parameter 5-15 Terminal 33 Digital Input	[0] No operation
Parameter 5-16 Terminal 31 Digital Input	[0] No operation
Parameter 6-10 Terminal 53 Low Voltage	4.0 mA
Parameter 6-11 Terminal 53 High Voltage	20.0 mA
Parameter 6-14 Terminal 53 Low Ref./ Feedb. Value	0
Parameter 6-15 Terminal 53 High Ref./ Feedb. Value	250
Parameter 6-19 Terminal 53 mode	[0] Current Mode
Parameter 14-01 Switching Frequency	10.0 kHz
Parameter 14-07 Dead Time Compensation Level	65
Parameter 14-64 Dead Time Compensation Zero Current Level	[0] Disabled
Parameter 14-65 Speed Derate Dead Time Compensation	250
Parameter 14-51 DC-Link Voltage Compensation	[0] Off
Parameter 30-20 High Starting Torque Time [s]	0
Parameter 30-21 High Starting Torque Current [%]	100
Parameter 30-22 Locked Rotor Protection	[0] Off
Parameter 30-23 Locked Rotor Detection Time [s]	1

Table 3.7 One Gear Drive (OGD)

For further examples, refer to *chapter 6 Application Examples*.

### 3.4 Jumper Terminal 12 and 27

When the factory default programming values are used, connect a jumper wire between terminal 12 and terminal 27 for the frequency converter to operate.

- Digital input terminal 27 is designed to receive a 24 V DC external interlock command. In many applications, wire an external interlock device to terminal 27.
- When no interlock device is used, wire a jumper between control terminal 12 and terminal 27. This provides internal 24 V signal on terminal 27.

- No signal present prevents the unit from operating.

### 3.5 Automatic Motor Adaptation (AMA)

#### Automatic motor adaptation (AMA)

It is highly recommended to run AMA because it measures the electrical characteristics of the motor to optimise compatibility between the frequency converter and the motor under VVC+ mode.

- The frequency converter builds a mathematical model of the motor for regulating output motor current, thus enhancing motor performance.
- Some motors are unable to run the complete version of the test. In that case, select *Enable reduced AMA*.
- If warnings or alarms occur, see *chapter 7.3 Warning and Alarm Code List*.
- Run this procedure on a cold motor for best results.

#### To run AMA using the numeric LCP

1. By default parameter setting, connect terminals 12 and 27 before running AMA.
2. Enter the *Main Menu*.
3. Go to parameter group 1-\*\* *Load and Motor*.
4. Press [OK].
5. Set motor parameters using nameplate data for parameter group 1-2\* *Motor Data*.
6. Set motor cable length in *parameter 1-42 Motor Cable Length*
7. Go to *parameter 1-29 Automatic Motor Adaptation (AMA)*.
8. Press [OK].
9. Select [1] *Enable complete AMA*.
10. Press [OK].
11. The test runs automatically and indicates when it is complete.

Depending on the power size, the AMA takes 3–10 minutes to complete.

#### **NOTICE**

The AMA function in FC 360 does not cause the motor to run, and it does not harm the motor.



## 4 Installation

### 4.1 Mechanical Installation

**Select the best possible operation site by considering:**

- Ambient operating temperature.
- Installation method.
- Cooling.
- Position of the frequency converter.
- Cable routing.
- Power source supplying correct voltage and necessary current.
- Motor current rating within the maximum current from the frequency converter.
- Correct rating of external fuses and circuit breakers.

**Cooling and Mounting:**

- Provide top and bottom clearance for air cooling, see *Table 4.1* for clearance requirements.
- Consider derating for temperatures starting from 45 °C and elevation 1000 m above sea level. See the *design guide* for details on derating.

Enclosure size	J1–J5	J6 and J7
Clearance above and below the unit [mm]	100	200

**Table 4.1 Minimum Airflow Clearance Requirements**

- Mount the unit vertically.
- IP20 units allow side-by-side installation.
- Improper mounting can result in overheating and reduced performance.
- Use the slotted mounting holes on the unit for wall mounting, when provided.
- See *chapter 8.4 Connection Tightening Torques* for proper tightening specifications.

## 4.2 Electrical Installation

This section describes how to wire the frequency converter.

4

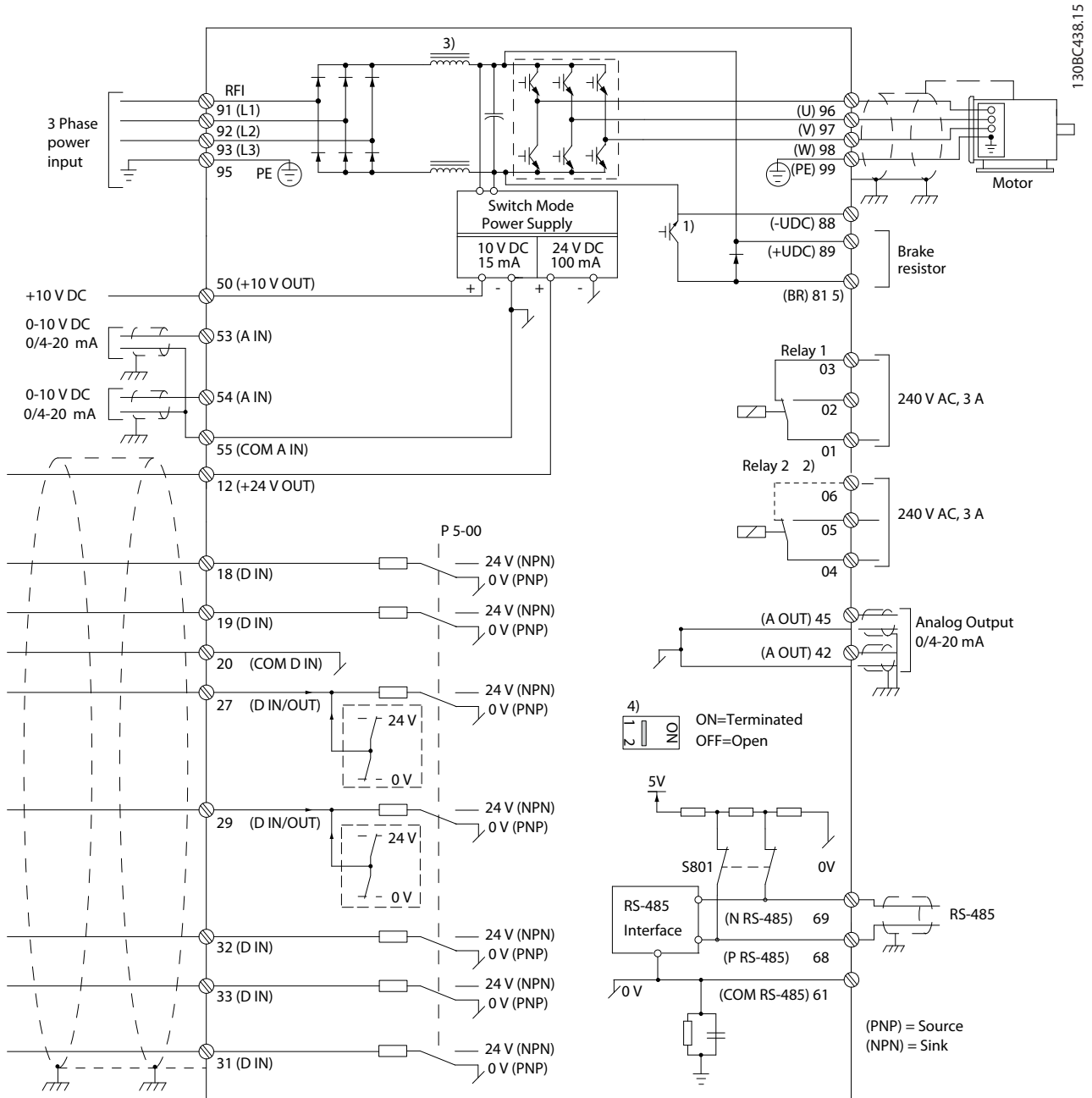

Illustration 4.1 Basic Wiring Schematic Drawing

A=Analog, D=Digital

1) Built-in brake chopper available from 0.37–22 kW.

2) Relay 2 is 2-pole for J1–J3 and 3-pole for J4–J7. Relay 2 of J4–J7 with terminals 4, 5, and 6 has the same NO/NC logic as relay 1. Relays are pluggable in J1–J5, and fixed in J6–J7.

3) Single DC choke in 0.37–22 kW (J1–J5); Dual DC choke in 30–75 kW (J6–J7).

4) Switch S801 (bus terminal) can be used to enable termination on the RS485 port (terminals 68 and 69).

5) No BR for 30–75 kW (J6–J7).

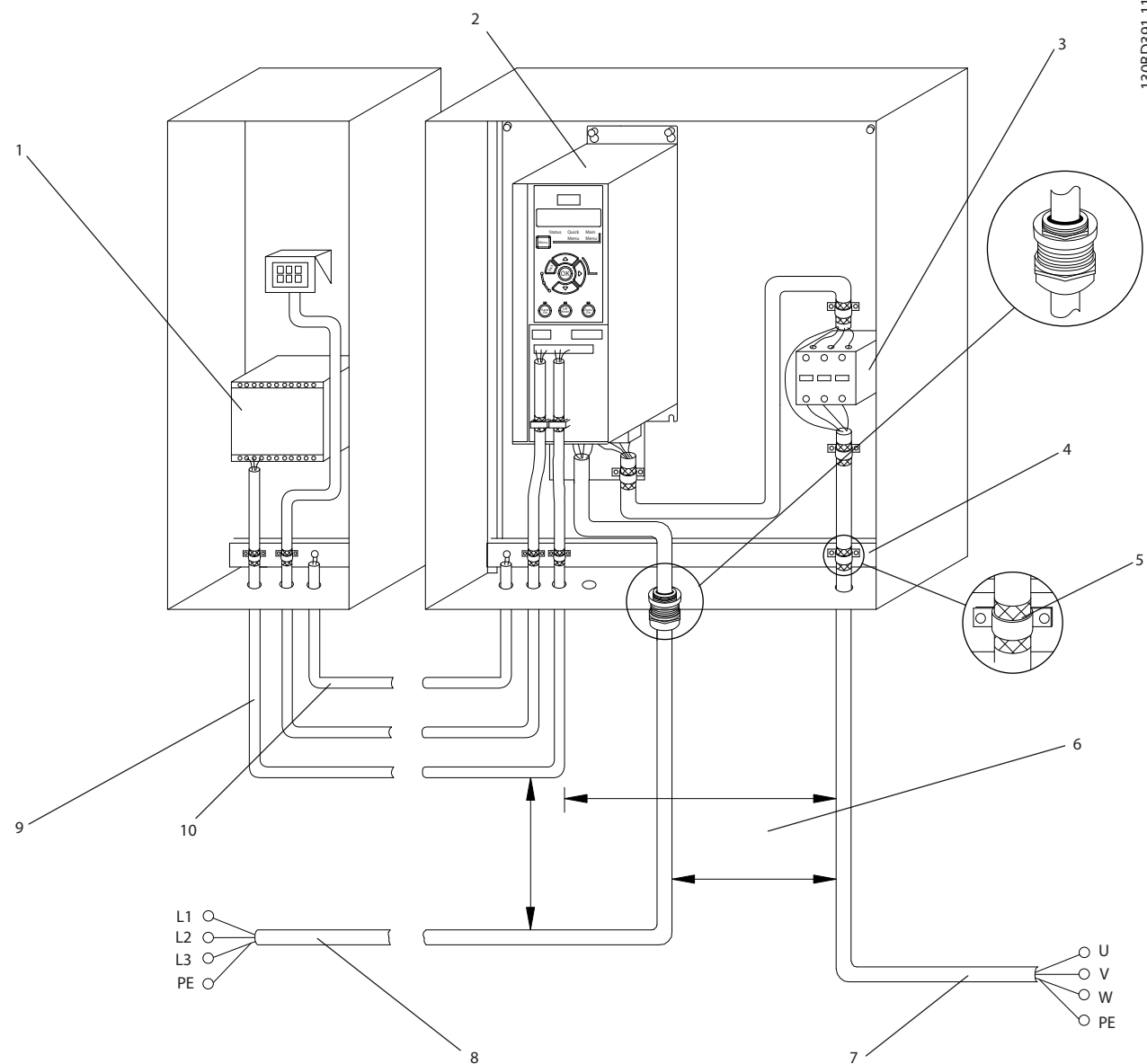

1	PLC	6	Minimum 200 mm (7.9 inch) between control cables, motor, and mains
2	Frequency converter	7	Motor, 3-phase and PE
3	Output contactor (not recommended)	8	Mains, 3-phase and reinforced PE
4	Grounding rail (PE)	9	Control wiring
5	Cable shielding (stripped)	10	Equalising minimum 16 mm <sup>2</sup> (6 AWG)

Illustration 4.2 Typical Electrical Connection

### 4.2.1 General Requirements

#### **⚠ WARNING**

##### **EQUIPMENT HAZARD!**

Rotating shafts and electrical equipment can be hazardous. It is important to protect against electrical hazards when applying power to the unit. All electrical work must conform to national and local electrical codes. Installation, start up, and maintenance must be performed only by trained and qualified personnel. Failure to follow these guidelines could result in death or serious injury.

#### **⚠ CAUTION**

##### **WIRING ISOLATION!**

Run input power, motor wiring, and control wiring in 3 separate metallic conduits or use separated screened cable for high frequency noise isolation. Failure to isolate power, motor, and control wiring could result in less than optimum frequency converter and associated equipment performance.

Run motor cables from multiple frequency converters separately. Induced voltage from output motor cables run together can charge equipment capacitors even with the equipment turned off and locked out.

- An electronically activated function within the frequency converter provides overload protection for the motor. The overload provides Class 20 motor overload protection.

##### **Wire type and ratings**

- All wiring must comply with local and national regulations regarding cross-section and ambient temperature requirements.
- Danfoss recommends that all power connections be made with a minimum 75 °C rated copper wire.
- See *chapter 8 Specifications* for recommended wire sizes.

### 4.2.2 Grounding Requirements

#### **⚠ WARNING**

##### **GROUNDING HAZARD!**

For operator safety, a certified electrical installer should ground the frequency converter in accordance with national and local electrical codes as well as instructions contained within this manual. Ground currents are higher than 3.5 mA. Failure to ground the frequency converter properly could result in death or serious injury.

- Establish proper protective grounding for equipment with ground currents higher than 3.5 mA must be established.
- A dedicated ground wire is required for input power, motor power, and control wiring.
- Use the clamps provided with the equipment for proper ground connections.
- Do not ground 1 frequency converter to another in a daisy chain fashion (see *Illustration 4.3*).
- Keep the ground wire connections as short as possible.
- Use high-strand wire to reduce electrical noise.
- Follow motor manufacturer wiring requirements.

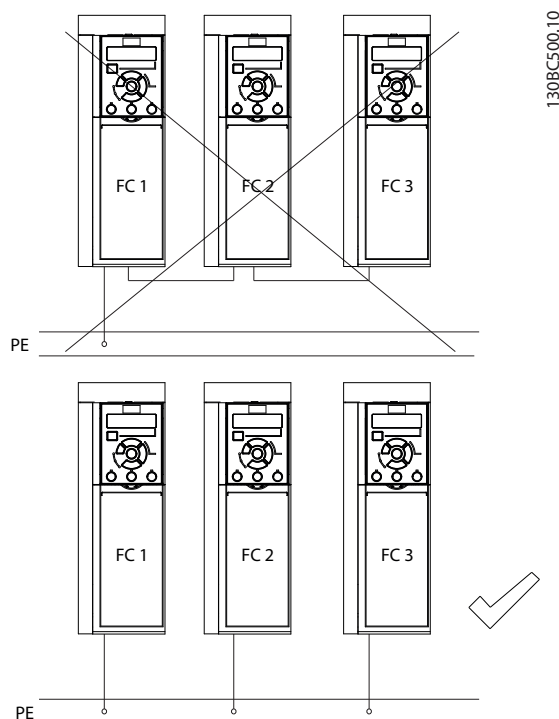

Illustration 4.3 Grounding Principle

### 4.2.3 Mains, Motor, and Ground Connections

#### **⚠ WARNING**

##### **INDUCED VOLTAGE!**

Run output motor cables from multiple frequency converters separately. Induced voltage from output motor cables run together can charge equipment capacitors even when the equipment is turned off and locked out. Failure to run output motor cables separately could result in death or serious injury.

Grounding clamps are provided for motor wiring (see *Illustration 4.4*).

- Do not install power factor correction capacitors between the frequency converter and the motor.
- Do not wire a starting or pole-changing device between the frequency converter and the motor.
- Follow motor manufacturer wiring requirements.
- All frequency converters must be used with an isolated input source as well as with ground reference power lines. When supplied from an isolated mains source (IT mains or floating delta) or TT/TN-S mains with a grounded leg (grounded delta), set *parameter 14-50 RFI Filter* to OFF (enclosure sizes J6–J7) or remove the RFI screw (enclosure sizes J1–J5). When off, the internal RFI filter capacitors between the chassis and the intermediate circuit are isolated to avoid damage to the intermediate circuit and reduce ground capacity currents in accordance with IEC 61800-3.
- Do not install a switch between the frequency converter and the motor in IT mains.

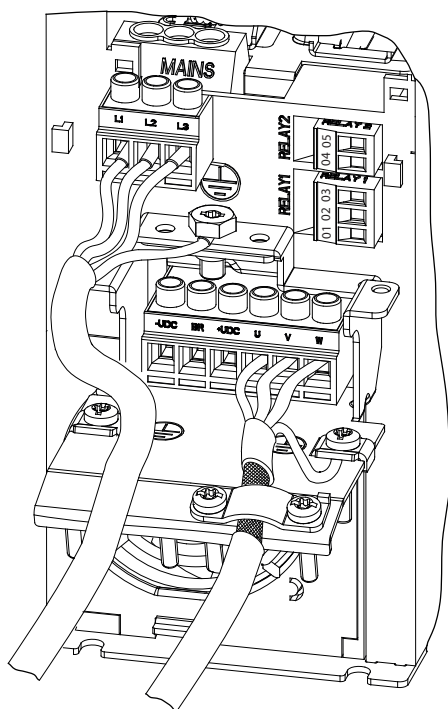

Illustration 4.4 Mains, Motor, and Ground Connections for Enclosure Sizes J1–J5

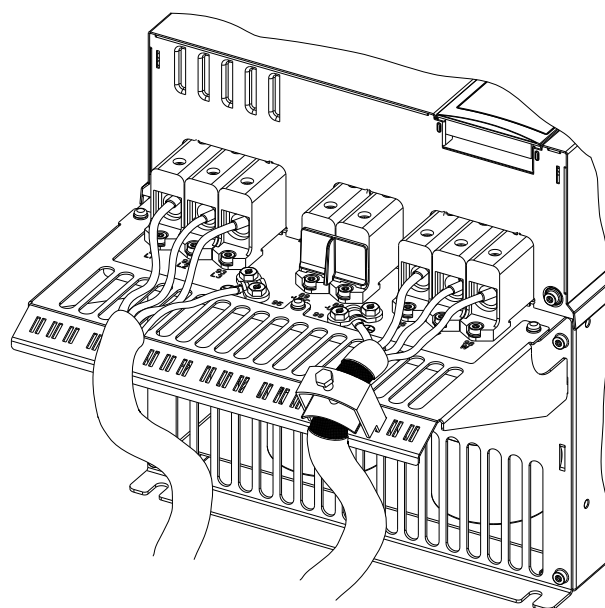

Illustration 4.5 Mains, Motor, and Ground Connections for Enclosure Size J7

Illustration 4.4 shows mains input, motor, and grounding for enclosure sizes J1–J5. Illustration 4.5 shows mains input, motor, and grounding for enclosure size J7. Actual configurations vary with unit types and optional equipment.

#### 4.2.4 Control Wiring

##### Access

- Remove the cover plate with a screwdriver. See Illustration 4.6.

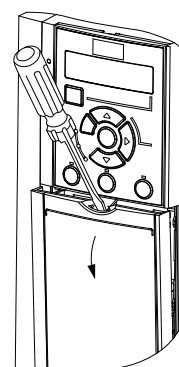

Illustration 4.6 Control Wiring Access for Enclosure Sizes J1–J7

**Control Terminal Types**

Illustration 4.7 shows the frequency converter control terminals. Terminal functions and default settings are summarised in Table 4.2.

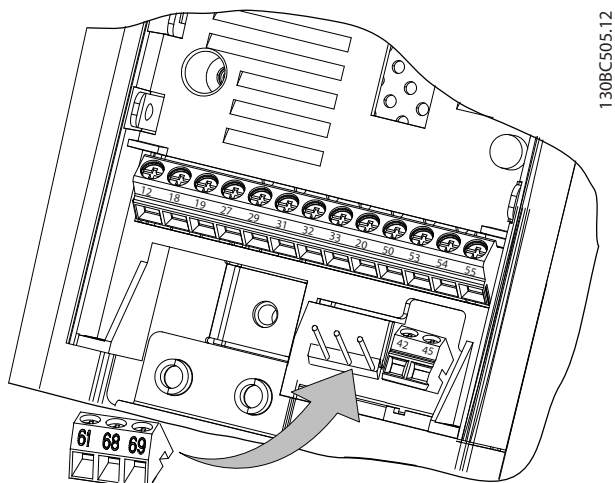

Illustration 4.7 Control Terminal Locations

See chapter 8.2 General Technical Data for terminal ratings details.

Terminal	Parameter	Default setting	Description
<b>Digital I/O, pulse I/O, encoder</b>			
12	-	+24 V DC	24 V DC supply voltage. Maximum output current is 100 mA for all 24 V loads.
18	Parameter 5-10 Terminal 18 Digital Input	[8] Start	Digital inputs.
19	Parameter 5-11 Terminal 19 Digital Input	[10] Reversing	
31	Parameter 5-16 Terminal 31 Digital Input	[0] No operation	
32	parameter 5-14 Terminal 32 Digital Input	[0] No operation	Digital input, 24 V encoder. Terminal 33 can be used for pulse input.
33	Parameter 5-15 Terminal 33 Digital Input	[0] No operation	

Terminal	Parameter	Default setting	Description
27	Parameter 5-12 Terminal 27 Digital Input parameter 5-30 Terminal 27 Digital Output	DI [2] Coast inverse DO [0] No operation	Selectable for either digital input, digital output, or pulse output. Default setting is digital input.
29	Parameter 5-13 Terminal 29 Digital Input parameter 5-31 Terminal 29 Digital Output	DI [14] Jog DO [0] No operation	Terminal 29 can be used for pulse input.
20	-		Common for digital inputs and 0 V potential for 24 V supply.
<b>Analog inputs/outputs</b>			
42	Parameter 6-91 Terminal 42 Analog Output	[0] No operation	Programmable analog output. The analog signal is 0–20 mA or 4–20 mA at a maximum of 500 Ω. Can also be configured as digital outputs
45	Parameter 6-71 Terminal 45 Analog Output	[0] No operation	
50	-	+10 V DC	10 V DC analog supply voltage. 15 mA maximum commonly used for potentiometer or thermistor.
53	6-1* parameter group	Reference	Analog input. Selectable for voltage or current.
54	6-2* parameter group	Feedback	
55	-		
<b>Serial communication</b>			
61	-		Integrated RC-filter for cable screen. ONLY for connecting the screen when experiencing EMC problems.

Terminal	Parameter	Default setting	Description
68 (+)	8-3* parameter group		RS485 interface. A control card switch is provided for termination resistance.
69 (-)	8-3* parameter group		
<b>Relays</b>			
01, 02, 03	5-40 [0]	[0] No operation	Form C relay output. These relays are in various locations depending upon the frequency converter configuration and size.
04, 05, 06	5-40 [1]	[0] No operation	Usable for AC or DC voltage and resistive or inductive loads. RO2 in J1-J3 enclosure is 2-pole, only terminals 04 and 05 are available

Table 4.2 Terminal Descriptions

**Control terminal functions**

Frequency converter functions are commanded by receiving control input signals.

- Programme each terminal for the function it supports in the parameters associated with that terminal.
- Confirm that the control terminal is programmed for the correct function. See *chapter 5 Local Control Panel and Programming* for details on accessing parameters and programming.
- The default terminal programming initiates frequency converter functioning in a typical operational mode.

**Using screened control cables**

The preferred method in most cases is to secure control and serial communication cables with screening clamps provided at both ends to ensure the best possible high frequency cable contact.

If the ground potential between the frequency converter and the PLC is different, electric noise could disturb the entire system. Solve this problem by fitting an equalising cable as close as possible to the control cable. Minimum cable cross-section: 16 mm<sup>2</sup> (6 AWG).

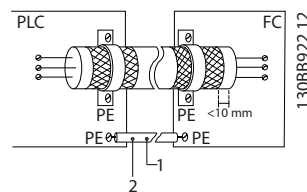

1	Minimum 16 mm <sup>2</sup> (6 AWG)
2	Equalising cable

Illustration 4.8 Screening Clamps at Both Ends

**50/60 Hz ground loops**

With long control cables, ground loops could occur. To eliminate ground loops, connect 1 end of the screen-to-ground with a 100 nF capacitor (keeping leads short).

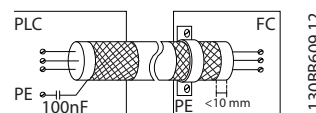
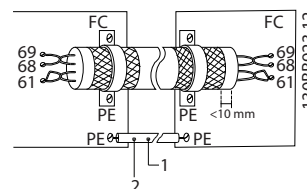

Illustration 4.9 Connection with a 100 nF Capacitor

**Avoid EMC noise on serial communication**

This terminal is connected to ground via an internal RC link. Use twisted-pair cables to reduce interference between conductors. The recommended method is shown in *Illustration 4.10*.



1	Minimum 16 mm <sup>2</sup> (6 AWG)
2	Equalising cable

Illustration 4.10 Twisted-pair Cables

Alternatively, the connection to terminal 61 can be omitted.

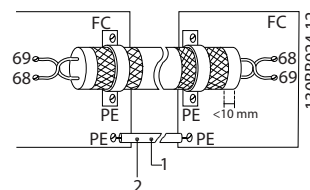

1	Minimum 16 mm <sup>2</sup> (6 AWG)
2	Equalising cable

Illustration 4.11 Twisted-pair Cables without Terminal 61

### 4.3 Serial Communication

Connect RS485 serial communication wiring to terminals (+)68 and (-)69.

- Screened serial communication cable is recommended.
- See *chapter 4.2.2 Grounding Requirements* for proper grounding.

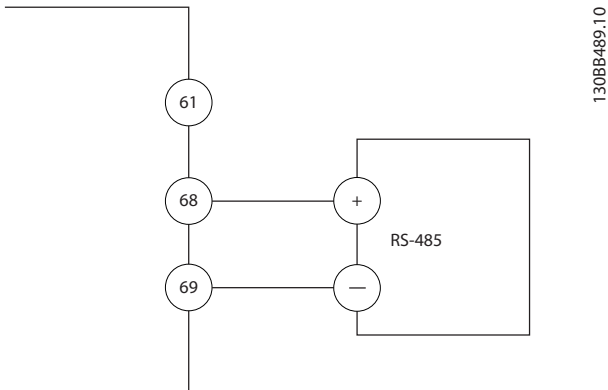

Illustration 4.12 Serial Communication Wiring Diagram

For basic serial communication set-up, select the following:

1. Protocol type in *parameter 8-30 Protocol*.
  2. Frequency converter address in *parameter 8-31 Address*.
  3. Baud rate in *parameter 8-32 Baud Rate*.
- Two communication protocols are internal to the frequency converter. Follow motor manufacturer wiring requirements.
    - Danfoss FC
    - Modbus RTU
  - Functions can be programmed remotely using the protocol software and RS485 connection, or in parameter group 8-\*\* *Communications and Options* .
  - Selecting a specific communication protocol changes various default parameter settings to match the specifications of the protocol, and makes extra protocol-specific parameters available.



## 5 Local Control Panel and Programming

### 5.1 Local Control Panel (LCP) Operations

FC 360 supports numerical local control panel (LCP 21), graphic local control panel (LCP 102), and blind cover. This chapter describes the operations with LCP 21 and LCP 102, as well as how to program with LCP 21.

#### NOTICE

The frequency converter can also be programmed from the MCT-10 Set-up Software on PC via RS485 com-port. This software can be ordered using code number 130B1000 or downloaded from the Danfoss website: [www.danfoss.com/BusinessAreas/DrivesSolutions/software-download](http://www.danfoss.com/BusinessAreas/DrivesSolutions/software-download).

#### 5.1.1 Numerical Local Control Panel (LCP 21)

The numerical local control panel (LCP 21) is divided into 4 functional sections.

- A. Numeric display.
- B. Menu key.
- C. Navigation keys and indicator lights (LEDs).
- D. Operation keys and indicator lights (LEDs).

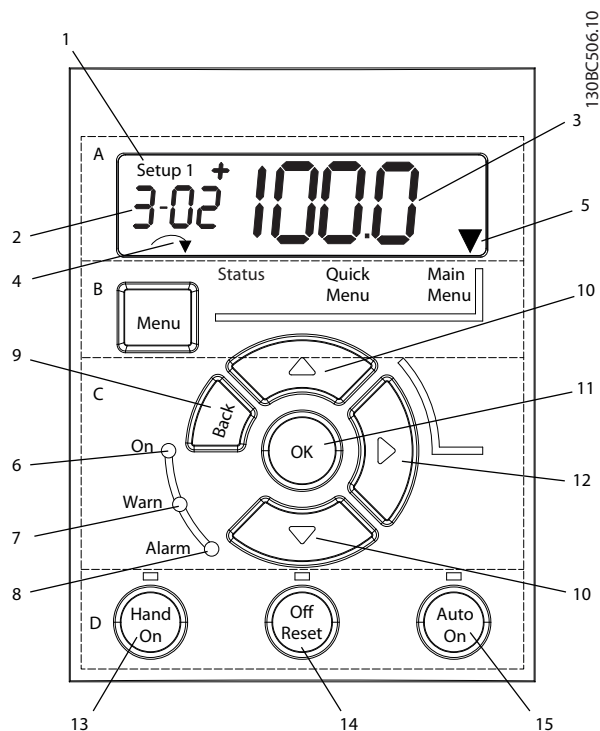

Illustration 5.1 View of the LCP 21

#### A. Numeric display

The LCD-display is back-lit with 1 numeric line. All data is displayed in the LCP.

1	The set-up number shows the active set-up and the edit set-up. If the same set-up acts as both active and edit set-up, only that set-up number is shown (factory setting). When active and edit set-up differ, both numbers are shown in the display (set-up 12). The number flashing indicates the edit set-up.
2	Parameter number.
3	Parameter value.
4	Motor direction is shown in the bottom left of the display, indicated by a small arrow pointing either clockwise or counterclockwise.
5	The triangle indicates whether the LCP is in <i>Status</i> , <i>Quick Menu</i> , or <i>Main Menu</i> .

Table 5.1 Legend to Illustration 5.1, Section A



Illustration 5.2 Display Information

#### B. Menu key

Press [Menu] to select between *Status*, *Quick Menu*, or *Main Menu*.

#### C. Navigation keys and indicator lights (LEDs)

6	Green LED/On: Control section is working.
7	Yellow LED/Warn.: Indicates a warning.
8	Flashing Red LED/Alarm: Indicates an alarm.
9	[Back]: For moving to the previous step or layer in the navigation structure.
10	Arrows [▲] [▼]: For switching between parameter groups, parameters, and within parameters, or increasing/decreasing parameter values. Arrows can also be used for setting local reference.
11	[OK]: For selecting a parameter and for accepting changes to parameter settings.
12	[▶]: For moving from left to right within the parameter value to change each digit individually.

Table 5.2 Legend to Illustration 5.1, Section C

D. Operation keys and indicator lights (LEDs)

13	[Hand On]: Starts the motor and enables control of the frequency converter via the LCP. <b>NOTICE</b> Parameter 5-12 Terminal 27 Digital Input has coast inverse as the default setting. This means that [Hand On] does not start the motor if there is no 24 V to terminal 27.
14	[Off/Reset]: Stops the motor (off). If in alarm mode, the alarm is reset.
15	[Auto On]: The frequency converter is controlled either via control terminals or serial communication.

Table 5.3 Legend to Illustration 5.1, Section D

**WARNING**

**HIGH VOLTAGE**

Touching the frequency converter after pressing the [Off/Reset] key is still dangerous, because the key does not disconnect the frequency converter from the mains.

- Disconnect the frequency converter from the mains, and wait for the frequency converter to fully discharge. See the discharge time in Table 2.1.

5.1.2 Local Control Panel LCP 102

The graphical local control panel (GLCP or LCP 102) has a larger display area, which displays more information than LCP 21.

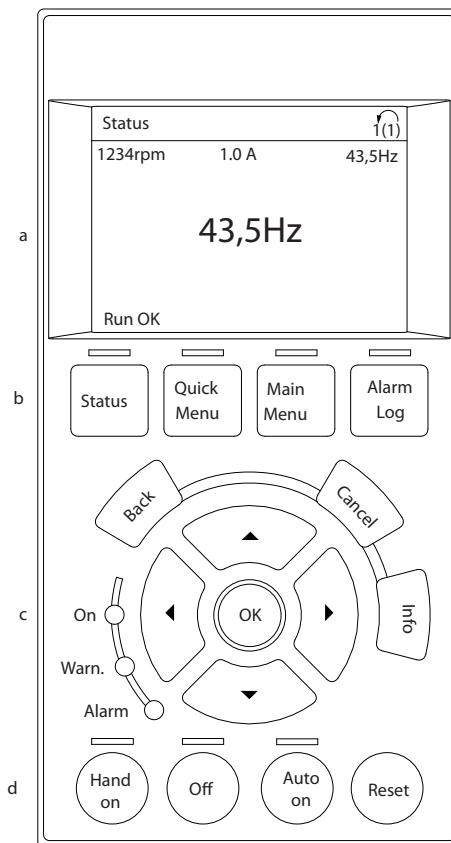

130BC362.10

Illustration 5.3 Local Control Panel LCP 102

- Display area.
- Menu keys for changing the display to show status, programming, or error message history.
- Navigation keys for programming functions, moving the display cursor, and speed control in local operation. Also included are the status indicator lights.
- Operational mode keys and reset.

**NOTICE**

The [Info] key does not function when the LCP 102 is connected to the frequency converter.

Functions

- English and Chinese display
- Status messages

- Quick menu for easy commissioning
- Parameter setting and explanation of parameter function
- Parameter adjustment
- Full parameter back-up and copy function
- Alarm logging
- Hand-operated start/stop, or automatic mode option
- Reset function

**Mounting**

Use the GLCP adapter and a cable to connect the LCP 102 to frequency converter, as shown in *Illustration 5.4*.

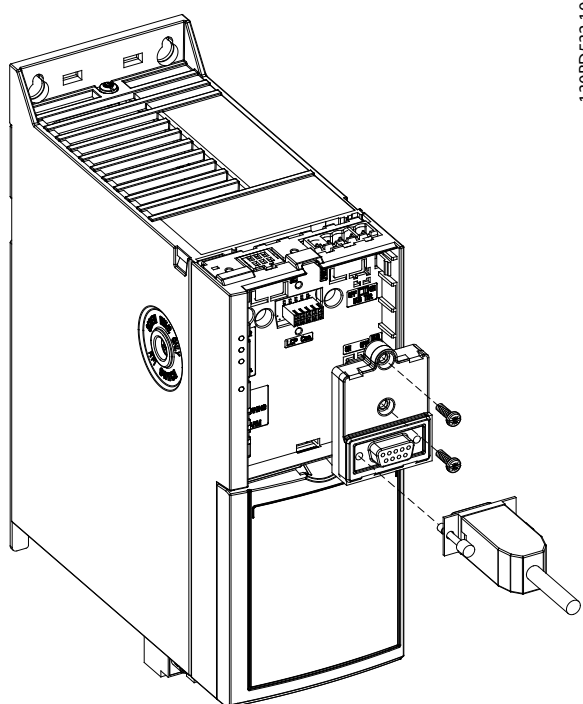

Illustration 5.4 GLCP Adapter and Connecting Cable

**5.1.3 The Right-key Function on LCP 21**

Press [▶] to edit any of the 4 digits on the display individually. When pressing [▶] once, the cursor moves to the first digit and the digit starts flashing as shown in *Illustration 5.5*. Press the [▲] [▼] to change the value. Pressing [▶] does not change the value of the digits or move the decimal point.

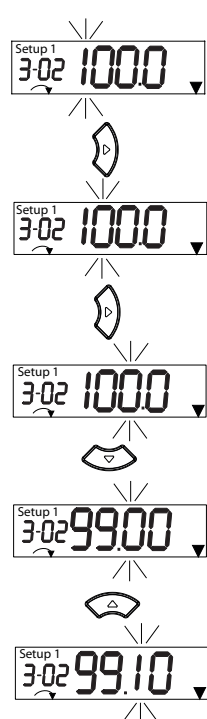

Illustration 5.5 Right-key Function

[▶] can also be used for moving between parameter groups. When in *Main Menu*, press [▶] to move to the first parameter in the next parameter group (for example, move from *parameter 0-03 Regional Settings [0] International* to *parameter 1-00 Configuration Mode [0] Open loop*).

**5.2 Main Menu**

The *Main Menu* gives access to all parameters.

1. To enter *Main Menu*, press [Menu] until the indicator in the display is placed above *Main Menu*.
2. [▲] [▼]: Browse through the parameter groups.
3. Press [OK] to select a parameter group.
4. [▲] [▼]: Browse through the parameters in the specific group.
5. Press [OK] to select the parameter.
6. [▶] and [▲] [▼]: Set/change the parameter value.
7. Press [OK] to accept the value.
8. To exit, press either [Back] twice (or 3 times for array parameters) to enter *Main Menu*, or press [Menu] once to enter *Status*.

See *Illustration 5.6*, *Illustration 5.7*, and *Illustration 5.8* for the principles of changing the value of continuous, enumerated, and array parameters, respectively. The actions in the illustrations are described in *Table 5.4*, *Table 5.5*, and *Table 5.6*.

5

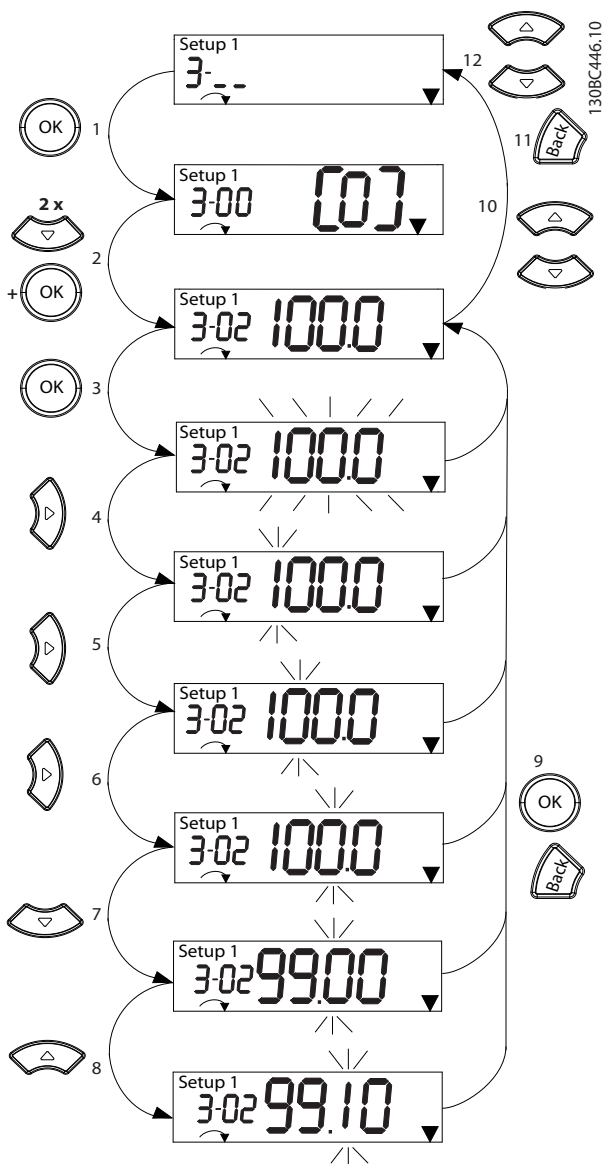

Illustration 5.6 Main Menu Interactions - Continuous Parameters

1	[OK]: The first parameter in the group is shown.
2	Press [▼] repeatedly to move down to the parameter.
3	Press [OK] to start editing.
4	[►]: First digit flashing (can be edited).
5	[►]: Second digit flashing (can be edited).
6	[►]: Third digit flashing (can be edited).
7	[▼]: Decreases the parameter value, the decimal point changes automatically.
8	[▲]: Increases the parameter value.
9	[Back]: Cancel changes, return to 2). [OK]: Accept changes, return to 2).
10	[▲][▼]: Select parameter within the group.
11	[Back]: Removes the value and shows the parameter group.
12	[▲][▼]: Select group.

Table 5.4 Changing Values in Continuous Parameters

For enumerated parameters, the interaction is similar, but the parameter value is shown in brackets, because of the LCP 21 digits limitation (4 large digits) and the enum can be greater than 99. When the enum value is greater than 99, the LCP 21 can only display the first part of the bracket.

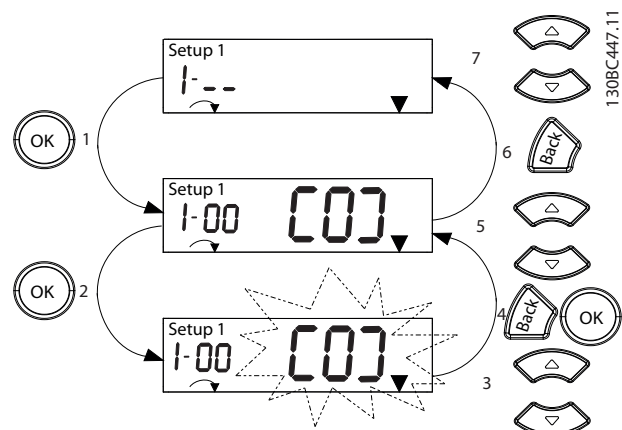

Illustration 5.7 Main Menu Interactions - Enumerated Parameters

1	[OK]: The first parameter in the group is shown.
2	Press [OK] to start editing.
3	[▲][▼]: Change parameter value (flashing).
4	Press [Back] to cancel changes or [OK] to accept changes (return to screen 2).
5	[▲][▼]: Select a parameter within the group.
6	[Back]: Removes the value and shows the parameter group.
7	[▲][▼]: Select a group.

Table 5.5 Changing Values in Enumerated Parameters

Array parameters function as follows:

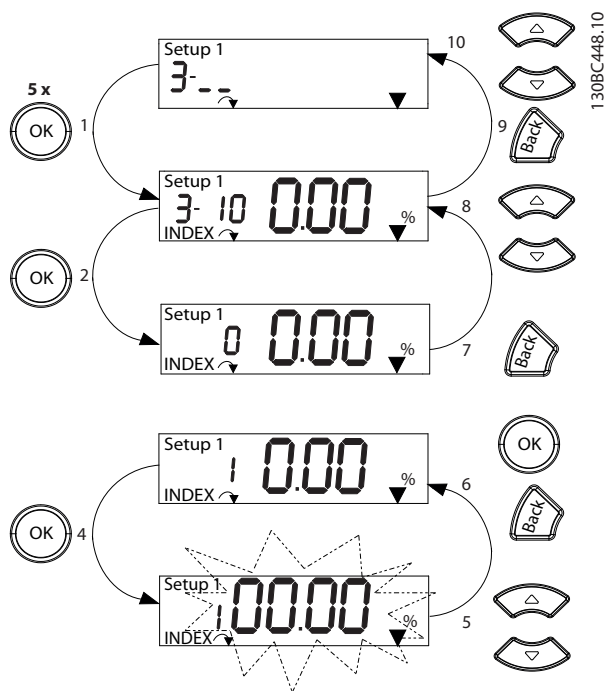

Illustration 5.8 Main Menu Interactions - Array Parameters

1	[OK]: Shows parameter numbers and the value in the first index.
2	[OK]: Index can be selected.
3	[▲][▼]: Select index.
4	[OK]: Value can be edited.
5	[▲][▼]: Change parameter value (flashing).
6	[Back]: Cancels changes. [OK]: Accepts changes.
7	[Back]: Cancels editing index, a new parameter can be selected.
8	[▲][▼]: Select parameter within the group.
9	[Back]: Removes parameter index value and shows the parameter group.
10	[▲][▼]: Select group.

Table 5.6 Changing Values in Array Parameters

### 5.3 Quick Menu

The *Quick Menu* gives easy access to the most frequently used parameters.

1. To enter *Quick Menu*, press [Menu] until the indicator in display is placed above *Quick Menu*.
2. Press [▲] [▼] to select either QM1 or QM2, then press [OK].
3. Press [▲] [▼] to browse through the parameters in *Quick Menu*.
4. Press [OK] to select a parameter.
5. Press [▲] [▼] to change the value of a parameter setting.
6. Press [OK] to accept the change.
7. To exit, press either [Back] twice (or 3 times if in QM2 and QM3) to enter *Status*, or press [Menu] once to enter *Main Menu*.

130BC445.12

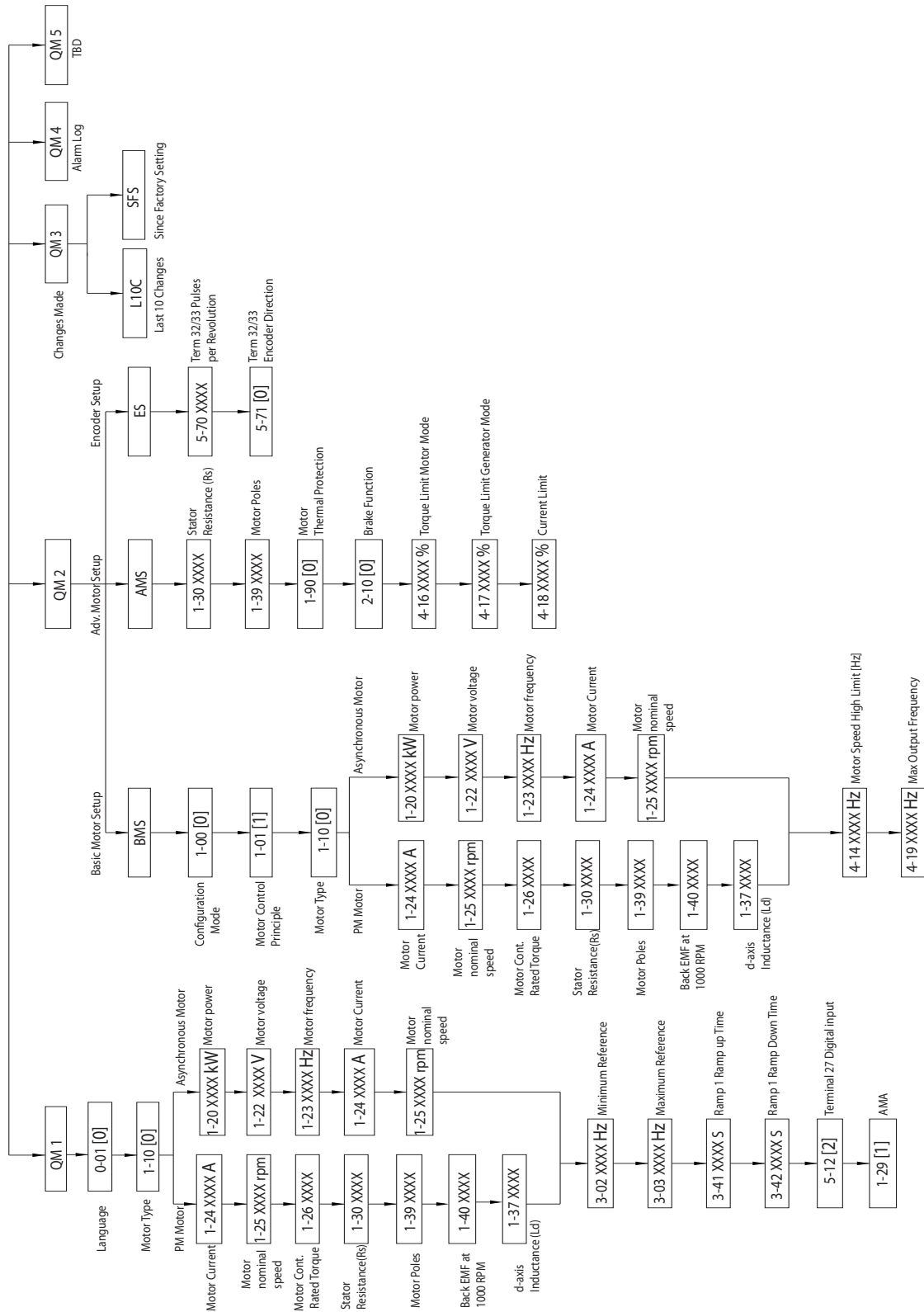

Illustration 5.9 Quick Menu Structure

## 5.4 PM Motor Set-up

### Initial programming steps

1. Set *parameter 1-10 Motor Construction* to the following options to activate PM motor operation:
  - 1a [1] PM, non salient SPM
  - 1b [2] PM, salient IPM, non Sat
  - 1c [3] PM, salient IPM, Sat
2. Select [0] *Open Loop* in *parameter 1-00 Configuration Mode*.

### NOTICE

Encoder feedback is not supported for PM motors.

### Programming motor data

When the initial programming steps are completed, the PM motor-related parameters in parameter groups 1-2\* *Motor Data*, 1-3\* *Adv. Motor Data*, and 1-4\* are active.

The information can be found on the motor nameplate and in the motor datasheet.

Programme the following parameters in the listed order:

1. *Parameter 1-24 Motor Current*.
2. *Parameter 1-26 Motor Cont. Rated Torque*.
3. *Parameter 1-25 Motor Nominal Speed*.
4. *Parameter 1-39 Motor Poles*.

Run a complete AMA using *parameter 1-29 Automatic Motor Adaption (AMA)[1] Enable Complete AMA*. If a complete AMA is not performed successfully, configure the following parameters manually.

1. *Parameter 1-30 Stator Resistance (Rs)*.  
Enter phase common stator winding resistance (Rs). If only phase-to-phase data is available, divide the phase-to-phase value by 2 to achieve the phase value.  
It is also possible to measure the value with an ohmmeter, which also takes the resistance of the cable into account. Divide the measured value by 2 and enter the result.
2. *Parameter 1-37 d-axis Inductance (Ld)*.  
Enter direct axis inductance of the PM motor. If only phase-to-phase data is available, divide the phase-to-phase value by 2 to achieve the phase value.  
It is also possible to measure the value with an inductance meter, which also takes the inductance of the cable into account. Perform the measurement multiple times to get the maximum phase-to-phase inductance value. Divide the value by 2 and enter the result.
3. *Parameter 1-38 q-axis Inductance (Lq)*.

This parameter is active only when *parameter 1-10 Motor Construction* is set to [2] *PM, salient IPM, non Sat* or [3] *PM, salient IPM, Sat*.

Enter the quadrature axis inductance of the PM motor. If only phase-to-phase data is available, divide the phase-to-phase value by 2 to achieve the phase value.

It is also possible to measure the value with an inductance meter, which also takes the inductance of the cable into account. Perform the measurement multiple times to get the minimum phase-to-phase inductance value. Divide the value by 2 and enter the result.

4. *Parameter 1-44 d-axis Inductance Sat. (LdSat)*.  
This parameter is active only when *parameter 1-10 Motor Construction* is set to [3] *PM, salient IPM, Sat*.  
This parameter corresponds to the saturation inductance of d-axis. The default value is the value set in *parameter 1-37 d-axis Inductance (Ld)*. Do not change the default value in most cases. If the motor supplier provides the saturation curve, enter the d-axis inductance value, which is 100% of the nominal current.
5. *Parameter 1-45 q-axis Inductance Sat. (LqSat)*.  
This parameter is active only when *parameter 1-10 Motor Construction* is set to [3] *PM, salient IPM, Sat*.  
This parameter corresponds to the saturation inductance of q-axis. The default value is the value set in *parameter 1-38 q-axis Inductance (Lq)*. In most cases, do not change the default. If the motor supplier provides the saturation curve, enter the q-axis inductance value, which is 100% of the nominal current.
6. *Parameter 1-40 Back EMF at 1000 RPM*.  
Enter the phase-to-phase back EMF RMS value of the PM motor at 1000 RPM mechanical speed. Back EMF is the voltage generated by a PM motor when no frequency converter is connected, and the shaft is turned externally. Back EMF is normally specified for nominal motor speed or for 1000 RPM measured between 2 lines. If the value is not available for a motor speed of 1000 RPM, calculate the correct value as follows: For example, if back EMF at 1800 RPM is 320 V, the back EMF at 1000 RPM is:  
Back EMF=(Voltage/  
RPM)x1000=(320/1800)x1000=178.  
Program this value for *parameter 1-40 Back EMF at 1000 RPM*.

### Test motor operation

1. Start the motor at low speed (100–1200 RPM). If the motor does not turn, check installation, general programming, and motor data.
2. Check if the start function in *parameter 1-70 PM Start Mode* fits the application requirements.

### Rotor detection

This function is the recommended selection for applications where the motor starts from standstill, for example pumps or conveyors. For some motors, a sound is heard when the frequency converter performs the rotor detection. This sound does not harm the motor. Adjust the value in *parameter 1-46 Position Detection Gain* for different motors. If the frequency converter fails to start, or an overcurrent alarm occurs when the frequency converter starts, check if the rotor is blocked or not. If the rotor is not blocked, set *parameter 1-70 PM Start Mode* to [1] *Parking* and try again.

### Parking

This function is the recommended option for applications where the motor is rotating at low speed, for example windmilling in fan applications. *Parameter 2-06 Parking Current* and *parameter 2-07 Parking Time* are adjustable. Increase the factory setting of these parameters for applications with high inertia.

Start the motor at nominal speed (100–200 RPM). If the application does not run well, check the VVC+ PM settings. *Table 5.7* shows recommendations in different applications.

Application	Settings
Low inertia applications $I_{Load}^1/I_{Motor}^2 < 5$	<ul style="list-style-type: none"> <li>• Increase the value for <i>parameter 1-17 Voltage filter time const.</i> by factor 5 to 10.</li> <li>• Reduce the value for <i>parameter 1-14 Damping Gain</i>.</li> <li>• Reduce the value (&lt;100%) for <i>parameter 1-66 Min. Current at Low Speed</i>.</li> </ul>
Medium inertia applications $50 > I_{Load}/I_{Motor} > 5$	Keep calculated values.
High inertia applications $I_{Load}/I_{Motor} > 50$	Increase the values for <i>parameter 1-14 Damping Gain</i> , <i>parameter 1-15 Low Speed Filter Time Const.</i> , and <i>parameter 1-16 High Speed Filter Time Const.</i>
High load at low speed <30% (rated speed)	Decrease <i>parameter 1-17 Voltage filter time const.</i> Decrease <i>parameter 1-66 Min. Current at Low Speed</i> (>100% for longer time can overheat the motor).

**Table 5.7 Recommendations in Different Applications**

1)  $I_{Load}$  = The inertia of load.

2)  $I_{Motor}$  = The inertia of motor

If the motor starts oscillating at a certain speed, increase *parameter 1-14 Damping Gain*. Increase the value in small steps.

Adjust the starting torque in *parameter 1-66 Min. Current at Low Speed*. 100% provides nominal torque as starting torque.



### 5.5 PROFIBUS

FC 360 frequency converters support PROFIBUS. If PROFIBUS is needed,

- Order a new frequency converter on which the control cassette with PROFIBUS is pre-installed;
- Order a control cassette with PROFIBUS to replace the standard control cassette on an existing frequency converter. In this case, upgrade the firmware with MCT-10 Set-up Software.

In both cases, ensure that *parameter 15-43 Software Version* is higher than 1.20.

*Illustration 5.10* shows the front panel of a control cassette with PROFIBUS.

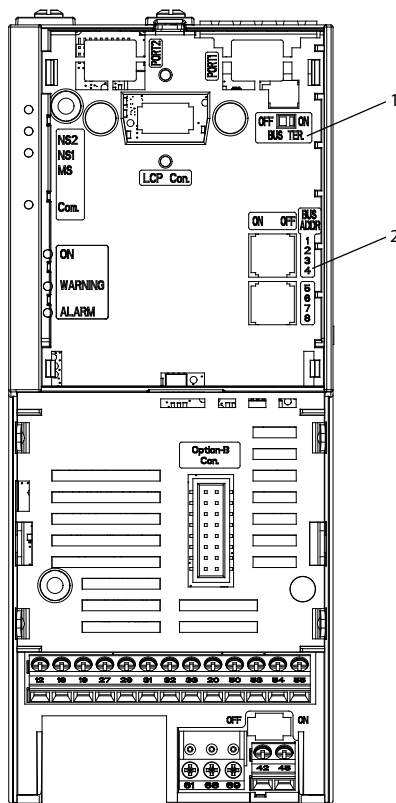

1	Termination resistor switch
2	PROFIBUS address selector

**Illustration 5.10** Front Panel of a Control Cassette with PROFIBUS

The functions of the LEDs and switches on the front panel are introduced in *Table 5.8*.

LED/Switch	Description
NS2	Not used for PROFIBUS.
NS1	Indicates the network status when communicating with the PROFIBUS master. When this indicator light shows constant green, data exchange between the master and the frequency converter is active.
MS	Indicates the module status, which is acyclic DP V1 communication from either a PROFIBUS master class 1 (PLC) or a master class 2 (MCT-10 Set-up Software, FDT tool). When this indicator light shows constant green, DP V1 communication from master classes 1 and 2 is active.
COM	Communication status for RS485. Not used for PROFIBUS.
Termination resistor switch	When the switch is turned on, the termination resistor is in effect.
PROFIBUS address selector	Use the switches in the selector to set the PROFIBUS address. The address change comes into effect at the next power-up. <b>NOTICE</b> Switch off the power supply before changing the switches.

**Table 5.8** Functions of LEDs and Switches

The PROFIBUS decoupling kit contains parts that are required for PROFIBUS to work. Install the kit after the control cassette with PROFIBUS is installed. *Illustration 5.11* and *Illustration 5.12* show how to install the decoupling kit on a frequency converter.

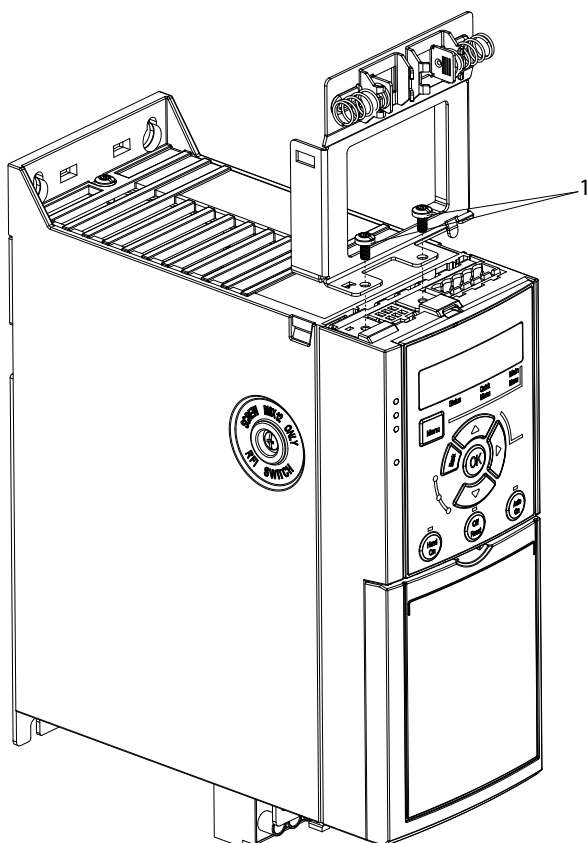
**5**

**Illustration 5.11** Fasten the Plate with Screws

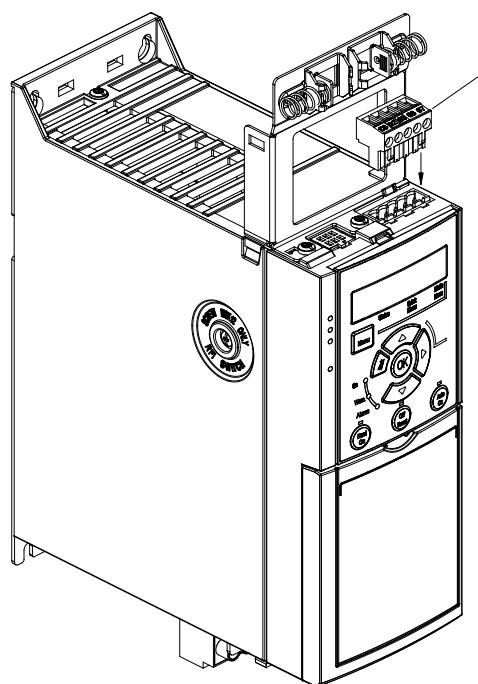

**Illustration 5.12** Push the 5-pin Connector into Place

## 5.6 PROFINET

FC 360 frequency converters support PROFINET. If PROFINET is needed,

- Order a new frequency converter on which the control cassette with PROFINET is pre-installed;
- Order a control cassette with PROFINET (ordering number: to replace the standard control cassette on an existing frequency converter. In this case, upgrade the software with MCT-10 Set-up Software. See the *Service Manual* for the instructions to upgrade the software.

In both cases, ensure that *parameter 15-43 Software Version* is higher than 1.40.

After the control cassette with PROFINET is installed, install the PROFINET decoupling kit that is included in the control cassette package.

To install the decoupling kit:

1. Place the decoupling plate on the control cassette that is mounted on the frequency converter, and fasten the plate using 2 screws (supplied), as shown in *Illustration 5.13*. Tightening torque 0.7–1.0 Nm.
2. Push the Ethernet cable connectors into the slots on the control cassette. Place Ethernet cables between the spring loaded metal clamps, as shown in *Illustration 5.14*, to establish mechanical

fixation and electrical contact between the cable and ground.

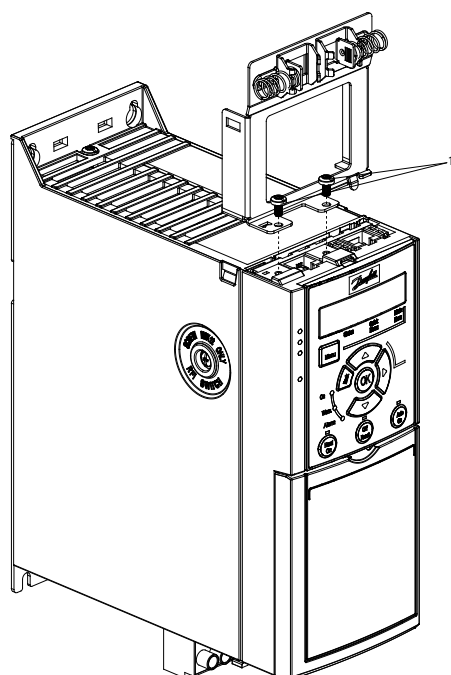

Illustration 5.13 Fasten the Plate with Screws

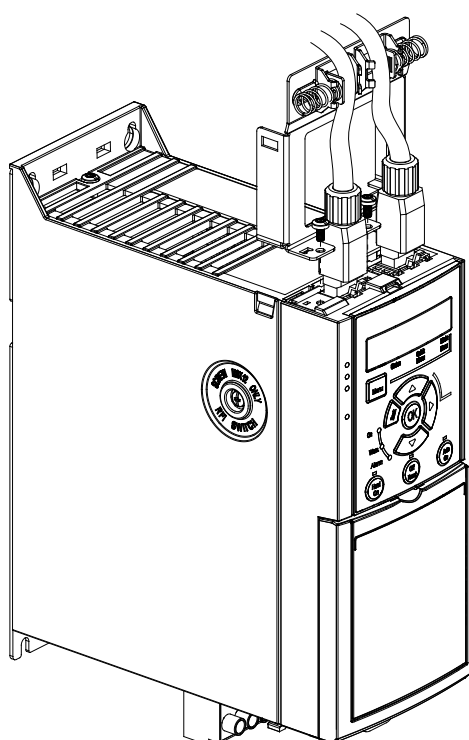

Illustration 5.14 Place Ethernet Cables between Clamps

## 5.7 Parameter List

0-0*	Operation / Display	0-1*	0-2*	0-3*	0-4*	0-5*	0-6*	0-7*	0-8*	0-9*	1-0*	1-1*	1-2*	1-3*	1-4*	1-5*	1-6*	1-7*	1-8*	1-9*	2-0*	2-1*	2-2*	2-3*	2-4*	2-5*	2-6*	2-7*	2-8*	2-9*	3-0*	3-1*	3-2*	3-3*	3-4*	3-5*	3-6*	3-7*	3-8*	3-9*	4-0*	4-1*	4-2*	4-3*	4-4*	4-5*	4-6*																																																																																														
0-0*	Basic Settings	0-01	Language	0-02	Regional Settings	0-03	Operating State at Power-up	0-04	GridType	0-05	>No copy	0-06	>Copy from setup 1<	0-07	>Copy from setup 2<	0-08	>Copy from Factory setup<	0-09	Password	0-10	Main Menu Password	0-11	Load and Motor	0-12	General Settings	0-13	Configuration Mode	0-14	>Open Loop<	0-15	>Speed closed loop<	0-16	>Torque closed loop<	0-17	>Process Closed Loop<	0-18	>Torque open loop<	0-19	>Surface Winder<	0-20	>Extended PID Speed OL<	0-21	>440-480V/60Hz/IT-grid<	0-22	>440-480V/50Hz/Delta<	0-23	>380-440V/50Hz/IT-grid<	0-24	>380-440V/50Hz/Delta<	0-25	>380-440V/60Hz/IT-grid<	0-26	>380-440V/60Hz/Delta<	0-27	>440-480V/60Hz/IT-grid<	0-28	>440-480V/60Hz/Delta<	0-29	>440-480V/60Hz<	0-30	Auto DC Braking	0-31	Set-up Operations	0-32	Active Set-up	0-33	>Set-up 1<	0-34	>Set-up 2<	0-35	>Multi Set-up<	0-36	Programming Set-up	0-37	Link Setups	0-38	Readout: Edit Set-ups / Channel	0-39	Application Selection	0-40	None	0-41	>Process Close Loop<	0-42	>Local/Remote<	0-43	>Speed Open Loop<	0-44	>Speed Close Loop<	0-45	>Multi Speed<	0-46	>OGD<	0-47	LCP Display	0-48	Display Line 1.1 Small	0-49	Display Line 1.2 Small	0-50	Display Line 1.3 Small	0-51	Display Line 2 Large	0-52	Display Line 3 Large	0-53	LCP Custom Readout	0-54	Custom Readout Unit	0-55	Custom Readout Min Value	0-56	Custom Readout Max Value	0-57	Display Text 1	0-58	Display Text 2	0-59	Display Text 3	0-60	LCP Keypad	0-61	[Hand on] Key on LCP	0-62	[Auto on] Key on LCP	0-63	[Off/Reset] Key on LCP	0-64	Copy/Save	0-65	LCP Copy	0-66	>No copy<	0-67	>All to LCP<	0-68	>All from LCP<	0-69	>Size indep. from LCP<	0-70	Set-up Copy
1-23	Motor Frequency	1-24	Motor Current	1-25	Motor Nominal Speed	1-26	Motor Cont. Rated Torque	1-27	Automatic Motor Adaption (AMA)	1-28	>Off<	1-29	>Enable Complete AMA<	1-30	>Enable Reduced AMA<	1-31	Adv. Motor Data I	1-32	Stator Resistance (Rs)	1-33	Rotor Resistance (Rr)	1-34	Stator Leakage Reactance (X1)	1-35	Main Reactance (Xh)	1-36	d-axis Inductance (Ld)	1-37	q-axis Inductance (Lq)	1-38	Motor Poles	1-39	Adv. Motor Data II	1-40	Back EMF at 1000 RPM	1-41	Motor Cable Length	1-42	Motor Cable Length Feet	1-43	Load Indep. Setting	1-44	Motor Magnetisation at Zero Speed	1-45	Min Speed Normal Magnetising [Hz]	1-46	U/f Characteristic - U	1-47	U/f Characteristic - F	1-48	Load Depen. Setting	1-49	Low Speed Load Compensation	1-50	High Speed Load Compensation	1-51	Slip Compensation	1-52	Slip Compensation Time Constant	1-53	Resonance Dampening	1-54	Resonance Dampening Time Constant	1-55	Min. Current at Low Speed	1-56	Start Adjustments	1-57	Start Delay	1-58	Start Function	1-59	>DC Hold/delay time<	1-60	>Coast/delay time<	1-61	>Start speed cw<	1-62	>Horizontal operation<	1-63	>VVC+ clockwise<	1-64	Flying Start	1-65	>Disabled<	1-66	>Enabled<	1-67	>Enabled Always<	1-68	>Enabled Ref. Dir.<	1-69	Enab. Always Ref. Dir.<	1-70	Start Current	1-71	Compressor Start Max Speed [Hz]	1-72	Compressor Start Max Time to Trip	1-73	Stop Adjustments	1-74	Function at Stop	1-75	>Coast<	1-76	>DC hold / Motor Preheat<	1-77	>Pre-magnetizing<	1-78	Min Speed for Function at Stop [Hz]	1-79	Motor Temperature	1-80	Motor Thermal Protection																										
2-00	DC Hold/Motor Preheat Current	2-01	DC Brake Current	2-02	DC Braking Time	2-03	DC Brake Cut In Speed	2-04	Parking Current	2-05	Parking Time	2-06	Brake Energy Funct.	2-07	Brake Function	2-08	>Off<	2-09	>Resistor brake<	2-10	>AC brake<	2-11	Brake Resistor (ohm)	2-12	Brake Power Limit (kW)	2-13	Brake voltage reduce	2-14	AC Brake, Max current	2-15	Over-voltage Control	2-16	>Disabled<	2-17	>Enabled (not at stop)<	2-18	>Enabled<	2-19	Over-voltage Gain	2-20	Mechanical Brake	2-21	Release Brake Current	2-22	Activate Brake Speed [Hz]	2-23	Reference / Ramps	2-24	Reference Limits	2-25	Reference Range	2-26	>Min - Max<	2-27	>Max - +Max<	2-28	Reference/Feedback Unit	2-29	Minimum Reference	2-30	Maximum Reference	2-31	Reference Function	2-32	>Sum<	2-33	>External/Preset<	2-34	Preset Reference	2-35	Preset Reference	2-36	>100-100%< *0%>	2-37	Jog Speed [Hz]	2-38	Catch up/slow Down Value	2-39	Preset Relative Reference	2-40	Reference 1 Source	2-41	>No function<	2-42	>Analog Input 53<	2-43	>Frequency input 29<	2-44	>Frequency input 33<	2-45	>Local bus reference<	2-46	>Bus PCD<	2-47	Reference 2 Source	2-48	Reference 3 Source																																												
3-18	Relative Scaling Reference	3-19	Ramp 1	3-20	Ramp 1 Type	3-21	>Linear<	3-22	>S-ramp Const Time<	3-23	Ramp 1 Ramp Up Time	3-24	>0.05-3600 s< * Size related	3-25	Ramp 1 Ramp Down Time	3-26	>0.05-3600 s< * Size related	3-27	Ramp 2	3-28	Ramp 2 Type	3-29	Ramp 2 Ramp Up Time	3-30	Ramp 2 Ramp Down Time	3-31	Ramp 3	3-32	Ramp 3 Type	3-33	Ramp 3 Ramp up Time	3-34	Ramp 3 Ramp down Time	3-35	Ramp 4	3-36	Ramp 4 Type	3-37	Ramp 4 Ramp up Time	3-38	Ramp 4 Ramp Down Time	3-39	Other Ramps	3-40	Jog Ramps	3-41	Quick Stop Ramp Time	3-42	Digital Potentiometer	3-43	Step Size	3-44	Power Restore	3-45	Maximum Limit	3-46	Minimum Limit	3-47	Ramp Delay	3-48	Motor Limits	3-49	Motor Speed Direction	3-50	>Clockwise<	3-51	>Both directions<	3-52	Motor Speed Low Limit [Hz]	3-53	Motor Speed High Limit [Hz]	3-54	Torque Limit Motor Mode	3-55	Torque Limit Generator Mode	3-56	Current Limit	3-57	Max Output Frequency	3-58	Limit Factors	3-59	Torque Limit Factor Source	3-60	Speed Limit Factor Source	3-61	Break Away Boost	3-62	Motor Fb Monitor	3-63	Motor Feedback Loss Function	3-64	Motor Feedback Speed Error	3-65	Motor Feedback Loss Timeout	3-66	Adj. Warnings 2	3-67	Warning Freq. Low	3-68	Warning Freq. High	3-69	Adjustable Temperature Warning	3-70	Adj. Warnings	3-71	Warning Current Low	3-72	Warning Current High	3-73	Warning Reference Low	3-74	Warning Reference High	3-75	Warning Feedback Low	3-76	Warning Feedback High																								

4-57	Warning Feedback High	[163]	>Pos. Idx Bit1<	[45]	>Bus ctrl.<	[15]	>Out of frequency range<	5-42	Off Delay, Relay
4-58	Missing Motor Phase Function	[164]	>Pos. Idx Bit2<	[46]	>Bus control, timeout: On<	[16]	>Below frequency, low<	5-5*	<b>Pulse Input</b>
4-6*	<b>Speed Bypass</b>	[165]	Core diameter source	[47]	>Bus control, timeout: Off<	[17]	>Above frequency, high<	5-50	Term. 29 Low Frequency
4-61	Bypass Speed From [Hz]	[166]	New diameter select	[55]	>Pulse output <	[18]	>Out of feedb. range<	5-51	Term. 29 High Frequency
4-63	Bypass Speed To [Hz]	[167]	Reset diameter	[56]	>Heat sink cleaning warning, high<	[19]	>Below feedback, low<	5-52	Term. 29 Low Ref./Feedb. Value
5-*	<b>Digital In/Out</b>	[168]	Winder jog forward	[60]	>Comparator 0<	[20]	>Above feedback, high<	5-53	Term. 29 High Ref./Feedb. Value
5-0*	Digital I/O mode	[169]	Winder jog reverse	[61]	>Comparator 1<	[21]	>Thermal warning<	5-55	Term. 33 Low Frequency
*10	Digital I/O Mode	[170]	Tension on	[62]	>Comparator 2<	[22]	>Ready, no thermal warning<	5-56	Term. 33 High Frequency
5-01	Terminal 27 Mode	5-11	Terminal 19 Digital Input	[63]	>Comparator 3<	[23]	>Remote,ready,no TW<	5-57	Term. 33 Low Ref./Feedb. Value
5-02	Terminal 29 Mode	5-12	Terminal 27 Digital Input	[64]	>Comparator 4<	[24]	>Reverse<	5-58	Term. 33 High Ref./Feedb. Value
5-1*	<b>Digital Inputs</b>	[32]	Pulse time based	[70]	>Logic rule 0<	[26]	>Bus OK<	5-60	Terminal 27 Pulse Output Variable
5-10	Terminal 18 Digital Input	5-14	Terminal 32 Digital Input	[71]	>Logic rule 1<	[27]	>Torque limit & stop<	*10]	>No operation<
10]	>No operation<	[82]	Encoder input B	[72]	>Logic rule 2<	[28]	>Brake, no brake warning<	[45]	>Bus ctrl.<
11]	>Reset<	5-15	Terminal 33 Digital Input	[73]	>Logic rule 3<	[29]	>Brake ready, no fault<	[48]	>Bus ctrl, timeout<
2]	>Coast inverse<	[32]	Pulse time based	[74]	>Logic rule 4<	[30]	>Brake fault (IGBT)<	[100]	>Output frequency<
3]	>Coast and reset inv<	[81]	Encoder input A	[75]	>Logic rule 5<	[31]	>Relay 123<	[101]	>Reference<
4]	>Quick stop inverse<	5-16	Terminal 31 Digital Input	[80]	>SL digital output A<	[32]	>Mech brake ctrl<	[102]	>Process Feedback<
5]	>DC-brake inverse<	5-3*	<b>Digital Outputs</b>	[81]	>SL digital output B<	[36]	>Control word bit 11<	[103]	>Motor Current<
6]	>Stop inverse<	[82]	Terminal 27 Digital Output	[83]	>SL digital output C<	[37]	>Control word bit 12<	[104]	>Torque rel to limit<
*8]	>Latched start<	*10]	>No operation<	[91]	>SL digital output D<	[40]	>Out of ref range<	[105]	>Torq relate to rated<
9]	>Reversing<	[2]	>Control Ready<	[160]	>No alarm<	[41]	>Below reference, low<	[106]	>Power<
10]	>Start reversing<	[3]	>Drive ready<	[161]	>Running reverse <	[42]	>Above ref, high<	[107]	>Speed<
12]	>Enable start forward<	[4]	>Stand-by/no warning<	[165]	>Local ref active <	[46]	>Bus control, timeout: On<	[109]	>Max Out Freq<
13]	>Enable start reverse<	[5]	>Running<	[166]	>Remote ref active<	[47]	>Bus control, timeout: Off<	5-62	Pulse Output Max Freq 27
14]	>Jog<	[6]	>Running/no warning<	[167]	>Start command activ<	[56]	>Heat sink cleaning warning, high<	5-63	Terminal 29 Pulse Output Variable
15]	>Preset reference on<	[7]	>Run on ref/no warn<	[169]	>Drive in hand mode<	[60]	>Comparator 0<	5-7*	<b>24V Encoder Input</b>
16]	>Preset ref bit 0<	[8]	>Alarm<	[170]	>Drive in auto mode<	[61]	>Comparator 1<	5-70	Term 32/33 Pulses Per Revolution
17]	>Preset ref bit 1<	[9]	>Alarm or warning<	[171]	>Homing Completed<	[62]	>Comparator 2<	5-71	Term 32/33 Encoder Direction
18]	>Preset ref bit 2<	[10]	>At torque limit<	[172]	>Target Position Reached<	[63]	>Comparator 3<	5-9*	<b>Bus Controlled</b>
19]	>Freeze reference<	[11]	>Out of current range<	[173]	>Position Control Fault<	[64]	>Comparator 4<	5-90	Digital & Relay Bus Control
20]	>Freeze output<	[12]	>Below current, low<	[174]	TLD indicator	[70]	>Logic rule 0<	5-93	Pulse Out 27 Bus Control
21]	>Speed up<	[13]	>Above current, high<	[175]	Running on tension	[71]	>Logic rule 1<	5-94	Pulse Out 27 Timeout Preset
22]	>Speed down<	[14]	>Out of frequency range<	[176]	Ready to run	[72]	>Logic rule 2<	5-95	Pulse Out 29 Bus Control
23]	>Set-up select bit 0<	[15]	>Below frequency, low<	[179]	Position Mech Brake	[73]	>Logic rule 3<	5-96	Pulse Out 29 Timeout Preset
26]	>Precise stop inverse<	[16]	>Above frequency, high<	[193]	>Sleep Mode<	[74]	>Logic rule 4<	6-*	<b>Analog In/Out</b>
28]	>Catch up<	[17]	>Out of feedb. range<	[194]	>Broken Belt Function<	[75]	>Logic rule 5<	6-0*	Analog I/O Mode
29]	>Slow down<	[18]	>Below feedback, low<	5-31	Terminal 29 Digital Output	[80]	>SL digital output A<	6-00	Live Zero Timeout Time
34]	>Ramp bit 0<	[19]	>Above feedback, high<	5-34	On Delay, Digital Output	[81]	>SL digital output B<	6-01	Live Zero Timeout Function
35]	>Ramp bit 1<	[20]	>Thermal warning<	5-35	Off Delay, Digital Output	[82]	>SL digital output C<	*10]	>Off<
51]	>External interlock<	[21]	>Ready, no thermal warning<	5-4*	<b>Relays</b>	[83]	>SL digital output D<	[1]	>Freeze output<
60]	>Counter A (up)<	[22]	>Remote,ready,no TW<	5-40	Function Relay	[160]	>No alarm<	[2]	>Stop<
61]	>Counter A (down)<	[23]	>Ready, no over/under voltage<	[0]	>No operation<	[161]	>Running reverse <	[3]	>Jogging<
62]	>Reset Counter A<	[24]	>Reverses<	[1]	>Control Ready<	[165]	>Local ref active <	[4]	>Max. speed<
63]	>Counter B (up)<	[25]	>Bus OK<	[2]	>Drive ready<	[166]	>Remote ref active<	[5]	>Stop and trip<
64]	>Counter B (down)<	[26]	>Torque limit & stop<	[3]	>Drive rdy/rem ctrl<	[167]	>Start command activ<	6-1*	<b>Analog Input 53</b>
65]	>Reset Counter B<	[27]	>Brake, no brake warning<	[4]	>Stand-by/no warning<	[168]	>Drive in hand mode<	6-10	Terminal 53 Low Voltage
72]	>PID error inverse<	[28]	>Brake ready, no fault<	[5]	>Running<	[169]	>Homing Completed<	>0-10 V< *0.07 V	
73]	>PID reset 1 part<	[29]	>Brake fault (IGBT)<	[6]	>Run in range/no warn<	[170]	>Run in auto mode<	>0-10 V< *10 V	
74]	>PID enable<	[30]	>Relay 123<	[7]	>Run on ref/no warn<	[171]	>Target Position Reached<	Terminal 53 Low Current	
150]	>Go To Home<	[31]	>Mech brake ctrl<	[8]	>Alarm<	[172]	>Position Control Fault<	>0-20 mA< *4 mA	
151]	>Home Ref. Switch<	[32]	>Control word bit 11<	*9]	>Alarm or warning<	[175]	Running on tension	Terminal 53 High Current	
155]	>HW Limit Positive<	[36]	>Control word bit 12<	[10]	>At torque limit<	[176]	Ready to run	>0-20 mA< *20 mA	
156]	>HW Limit Negative<	[37]	>Out of ref range<	[11]	>Out of current range<	[179]	Position Mech Brake	Terminal 53 Low Ref./Feedb. Value	
157]	>Pos. Quick Stop<	[40]	>Below reference, low<	[12]	>Below current, low<	[193]	>Sleep Mode<	Terminal 53 High Ref./Feedb. Value	
160]	>Go To Target Pos<	[42]	>Above ref, high<	[13]	>Above current, high<	[194]	>Broken Belt Function<	Terminal 53 Filter Time Constant	
162]	>Pos. Idx Bit0<	[43]	>Extended PID Limit<	[14]	>Above current, high<	5-41	On Delay, Relay	Terminal 53 mode	

10]	>Current mode<	7-05	>0.0-2000 ms< *30.0 ms	7-53	Process PID Feed Fwd Ramp down	8-82	Slave Messages Rcvd	12-12	Auto Negotiation
*[11]	>Voltage mode<	7-06	Speed PID Diff. Gain Limit	7-56	Process PID Ref. Filter Time	8-83	Slave Error Count	12-13	Link Speed
<b>6-2*</b>	<b>Analog Input 54</b>	7-07	>1.0-20.0< *5.0	7-57	Process PID Fb. Filter Time	8-84	Slave Messages Sent	12-14	Link Duplex
6-20	Terminal 54 Low Voltage	7-08	Speed PID Lowpass Filter Time	<b>7-6*</b>	<b>Feedback Conversion</b>	8-85	Slave Timeout Errors	<b>12-8*</b>	<b>Other Ethernet Services</b>
6-22	Terminal 54 High Voltage	7-09	Speed PID Feedback Gear Ratio	*[0]	>Linear<	8-88	Reset FC port Diagnostics	12-8*	FTP Server
6-23	Terminal 54 Low Current	7-10	Speed PID Feed Forward Factor	[1]	>Square root<	<b>8-9*</b>	<b>Bus Feedback</b>	12-81	HTTP Server
6-24	Terminal 54 High Current	7-11	<b>Torque PID Ctrl.</b>	7-62	Feedback 2 Conversion	8-90	Bus Jog 1 Speed	12-82	SMTP Service
6-25	Terminal 54 High Ref./Feedb. Value	7-12	Torque PID Proportional Gain	<b>8-*</b>	<b>Comm. and Options</b>	8-91	Bus Jog 2 Speed	12-89	Transparent Socket Channel Port
6-26	Terminal 54 Filter Time Constant	7-13	Torque PID Integration Time	<b>8-*</b>	<b>General Settings</b>	<b>9-*</b>	<b>PROFdrive</b>	<b>12-9*</b>	<b>Advanced Ethernet Services</b>
6-29	Terminal 54 mode	7-20	<b>Process Ctrl. Feedb</b>	8-01	Control Site	9-00	Setpoint	12-90	Cable Diagnostics
[0]	>Current mode<	[1]	>No function<	8-02	Control Source	9-07	Actual Value	12-91	Auto Cross Over
<b>6-7*</b>	<b>Analog/Digital Output 45</b>	[2]	>Analog input 53<	8-03	Control Timeout Time	9-15	PCD Write Configuration	12-92	IGMP Snooping
6-70	Terminal 45 Mode	[3]	>Frequency input 29<	8-04	Control Timeout Function	9-16	PCD Read Configuration	12-92	Cable Error Length
[1]	>0-20 mA<	[4]	>Frequency input 33<	8-07	Diagnosis Trigger	9-18	Node Address	12-93	Broadcast Storm Filter
[2]	>Digital Output<	7-22	Process CL Feedback 2 Resource	8-1*	<b>Ctrl. Word Settings</b>	9-19	Drive Unit System Number	12-94	Broadcast Storm Filter
*[0]	>No operation<	7-30	Process PID Ctrl.	8-14	Configurable Control Word CTW	9-23	Telegram Selection	12-96	Port Config
[100]	>Output frequency<	*[0]	>Normal<	8-3*	<b>FC Port Settings</b>	9-27	Parameter Edit	12-98	Interface Counters
[101]	>Reference<	[1]	>Invert<	8-30	Protocol	9-44	Fault Message Counter	13-0*	<b>Smart Logic</b>
[102]	>Process Feedback<	[2]	>FC<	8-31	Address	9-45	Fault Code	13-0*	SL Controller Mode
[103]	>Motor Current<	[3]	>Process PID Anti Windup	[0]	>Off<	9-52	Fault Number	*[0]	>Off<
[104]	>Torque rel to limit<	[1]	>On<	8-32	Baud Rate	9-53	Fault Situation Counter	[1]	>On<
[105]	>Torq relate to rated<	7-32	Process PID Start Speed	[2]	>Modbus RTU<	9-52	Fault Situation Counter	[1]	>On<
[106]	>Power<	7-33	>0 - 6000 rpm< *0 rpm	8-33	Parity / Stop Bits	9-53	Profibus Warning Word	[0]	>False<
[107]	>Speed<	7-34	Process PID Proportional Gain	[0]	>2400 Baud<	9-63	Actual Baud Rate	[1]	>True<
[111]	Speed Feedback<	7-35	>0.00 - 10.00< *0.01	[1]	>4800 Baud<	9-64	Device Identification	[2]	>Running<
[113]	PID Clamped Output	7-36	Process PID Integral Time	[2]	>9600 Baud<	9-65	Profile Number	[3]	>In range<
[139]	>Bus Control<	7-38	>0.10-9999.00 s< *9999.00 s	[3]	>19200 Baud<	9-68	Status Word 1	[4]	>Out of current range<
6-72	Terminal 45 Digital Output	7-39	Process PID Differentiation Time	[4]	>38400 Baud<	9-70	Programming Set-up	[8]	>Below 1 low<
6-73	Terminal 45 Output Min Scale	7-40	>0.00-20.00 s< *0.00 s	[5]	>57600 Baud<	9-71	ProfibusSave Data Values	[9]	>Above 1 high<
6-74	Terminal 45 Output Max Scale	7-41	Process PID Diff. Gain Limit	[6]	>76800 Baud<	9-72	ProfibusDriveReset	[16]	>Thermal warning<
6-76	Terminal 45 Output Bus Control	7-42	Process PID Feed Forward Factor	[7]	>115200 Baud<	9-75	DO Identification	[17]	>Mains out of range<
<b>6-9*</b>	<b>Analog/Digital Output 42</b>	7-43	>0-200%< *0%	8-33	Parity / Stop Bits	9-80	Defined Parameters (1)	[18]	>Reversing<
6-90	Terminal 42 Mode	7-44	On Reference Bandwidth	[10]	>Even Parity, 1 Stop Bit<	9-81	Defined Parameters (2)	[19]	>Warning<
6-91	Terminal 42 Analog Output	7-45	<b>Adv. Process PID I</b>	[2]	>No Parity, 1 Stop Bit<	9-82	Defined Parameters (3)	[20]	>Alarm (trip)<
6-92	Terminal 42 Digital Output	7-46	Process PID I-part Reset	[3]	>No Parity, 2 Stop Bits<	9-83	Defined Parameters (4)	[21]	>Alarm (trip lock)<
6-93	Terminal 42 Output Min Scale	7-47	Process PID Output Neg. Clamp	8-35	Minimum Response Delay	9-84	Defined Parameters (5)	[22]	>Comparator 0<
6-94	Terminal 42 Output Max Scale	7-48	Process PID Output Pos. Clamp	8-36	Maximum Response Delay	9-90	Changed Parameters (1)	[23]	>Comparator 1<
6-96	Terminal 42 Output Bus Control	7-49	Process PID Gain Scale at Min. Ref.	8-37	Maximum Inter-char delay	9-91	Changed Parameters (2)	[24]	>Comparator 2<
6-98	Drive Type	7-50	Process PID Gain Scale at Max. Ref.	8-4*	<b>FC MC protocol set</b>	9-92	Changed Parameters (3)	[25]	>Comparator 3<
<b>7-*</b>	<b>Controllers</b>	7-51	Process PID Feed Fwd Resource	8-42	PCD Write Configuration	9-93	Changed Parameters (4)	[26]	>Logic rule 0<
<b>7-0*</b>	<b>Speed PID Ctrl.</b>	7-52	>No function<	8-43	PCD Read Configuration	9-94	Changed Parameters (5)	[27]	>Logic rule 1<
7-00	Speed PID Feedback Source	*[0]	>No function<	<b>8-5*</b>	<b>Digital/Bus</b>	<b>12-*</b>	<b>Ethernet</b>	[28]	>Logic rule 2<
[1]	>24V encoder<	[1]	>Analog input 53<	8-50	Coasting Select	12-0*	<b>IP Settings</b>	[29]	>Logic rule 3<
[2]	>MCB 102<	[2]	>Analog input 54<	8-51	Quick Stop Select	12-00	IP Address Assignment	[33]	>Digital input DI18<
[3]	>MCB 103<	[7]	>Frequency input 29<	8-52	DC Brake Select	12-01	IP Address	[34]	>Digital input DI19<
[6]	>Analog input 53<	[8]	>Frequency input 33<	8-53	Start Select	12-02	Subnet Mask	[35]	>Digital input DI27<
[7]	>Frequency input 54<	[11]	>Local bus reference<	8-54	Reversing Select	12-03	Default Gateway	[36]	>Digital input DI29<
[8]	>Frequency input 54<	[32]	>Bus PCD<	8-55	Set-up Select	12-04	DHCP Server	*[39]	>Start command<
[9]	>Frequency input 33<	7-46	Process PID Feed Fwd Normal/ Inv. Ctrl.	8-56	Preset Reference Select	12-05	Lease Expires	[40]	>Drive stopped<
*[20]	>None<	7-48	PCD Feed Forward	8-57	Profidrive OFF2 Select	12-06	Name Servers	[42]	>Auto Reset Trip<
7-02	Speed PID Proportional Gain	7-49	Process PID Output Normal/ Inv. Ctrl.	8-58	Profidrive OFF3 Select	12-07	Domain Name	[50]	>Comparator 4<
7-03	>0.000-1.000< *0.015	<b>7-5*</b>	<b>Adv. Process PID II</b>	<b>8-7*</b>	<b>Protocol SW Version</b>	12-08	Host Name	[51]	>Comparator 5<
>2.0-20000.0 ms< *8.0 ms	Speed PID Integral Time	7-50	Process PID Extended PID	<b>8-8*</b>	<b>FC Port Diagnostics</b>	12-09	Physical Address	[60]	>Logic rule 4<
7-04	Speed PID Differentiation Time	7-51	Process PID Feed Fwd Gain	8-80	Bus Message Count	12-10	Link Status	[61]	>Logic rule 5<
		7-52	Process PID Feed Fwd Ramp up	8-81	Bus Error Count	12-11	Link Duration	[83]	>Broken Belt<

[1] >On<	>Automatic reset x 1<	[10] >16.0 kHz<	16-13 Frequency	17-56 Encoder Sim. Resolution
[2] >Automatic reset x 2<	>Automatic reset x 2<	14-64 Dead Time Compensation Zero Current Level	16-14 Motor current	17-59 Resolver Interface
*[0] >Do not reset SLC<	>Automatic reset x 3<	14-65 Speed Derate Dead Time Compensation	16-15 Frequency [%]	<b>17-6* Monitoring and App.</b>
[1] >Reset SLC<	>Automatic reset x 4<	14-8* Options	16-16 Torque [Nm]	<b>18-** Data Readouts 2</b>
[13-1* Comparators	>Automatic reset x 5<	14-89 Option Detection	16-18 Motor Thermal	<b>18-9* PID Readouts</b>
13-10 Comparator Operand	>Automatic reset x 6<	14-9* Fault Settings	16-22 Torque [%]	18-90 Process PID Error
13-11 Comparator Operator	>Automatic reset x 7<	14-90 Fault Level	16-3* Drive Status	18-91 Process PID Output
13-12 Comparator Value	>Automatic reset x 8<	15-** Drive Information	16-30 DC Link Voltage	18-92 Process PID Clamped Output
13-2* Timers	>Automatic reset x 9<	15-61 Option SW Version	16-33 Brake Energy / 2 min	18-93 Process PID Gain Scaled Output
13-20 SL Controller Timer	>Automatic reset x 10<	15-62 Option Ordering No	16-34 Heatsink Temp.	<b>22-** Appl. Functions</b>
13-4* Logic Rules	>Automatic reset x 15<	15-63 Option Serial No	16-35 Inverter Thermal	<b>22-4* Sleep Mode</b>
13-40 Logic Rule Boolean 1	>Automatic reset x 20<	15-70 Option in Slot A	16-36 Inv. Nom. Current	22-40 Minimum Run Time
13-41 Logic Rule Operator 1	>Infinite auto reset<	15-71 Slot A Option SW Version	16-37 Inv. Max. Current	22-41 Minimum Sleep Time
13-42 Logic Rule Boolean 2	>Reset at power-up<	15-00 Operating Data	16-38 SL Controller State	22-43 Wake-Up Speed [Hz]
13-43 Logic Rule Operator 2	Automatic Restart Time	15-01 Running hours	16-39 Control Card Temp.	22-44 Wake-Up Ref./FB Diff
13-44 Logic Rule Boolean 3	>0-600 s< *10 s	15-02 KWh Counter	16-5* Ref. & Feeds.	22-45 Setpoint Boost
13-5* States	Operation Mode	15-03 Power Up's	16-50 External Reference	22-46 Maximum Boost Time
13-51 SL Controller Event	>Normal operation<	15-04 Over Temp's	16-52 Feedback[Unit]	22-47 Sleep Speed [Hz]
13-52 SL Controller Action	>Initialisation<	15-05 Over Volt's	16-5* Inputs & Outputs	<b>22-6* Broken Belt Detection</b>
<b>14-** Special Functions</b>	Trip Delay at Current Limit	15-06 Reset kWh Counter	16-60 Digital Input	22-61 Broken Belt Torque
<b>14-0* Inverter Switching</b>	Trip Delay at Torque Limit	15-07 Reset Running Hours Counter	16-61 Terminal 53 Setting	22-62 Broken Belt Delay
14-01 Switching Frequency	Action At Inverter Fault	15-3* Alarm Log	16-62 Analog Input 53	<b>30-** Special Features</b>
[0] >Ran3<	>Trip<	15-30 Alarm Log: Error Code	16-63 Terminal 54 Setting	<b>30-2* Adv. Start Adjust</b>
[1] >Ran5<	>Warning or trip after warning<	15-31 InternalFaultReason	16-64 Analog Input A154	30-20 High Starting Torque Time [s]
[2] >2.0 kHz<	Production Settings	15-40 FC Type	16-65 Analog Output 42 [mA]	30-21 High Starting Torque Current [%]
[3] >3.0 kHz<	Service Code	15-41 Power Section	16-66 Digital Output	30-22 Locked Rotor Protection
[4] >4.0 kHz<	Current Limit Ctrl.	15-42 Voltage	16-67 Pulse Input 29[Hz]	30-23 Locked Rotor Detection Time [s]
*[5] >5.0 kHz<	Current Lim Ctrl, Proportional Gain	15-43 Software Version	16-68 Pulse Input 33 [Hz]	<b>32-** Motion Control Basic Settings</b>
[6] >6.0 kHz<	Current Lim Ctrl, Integration Time	15-44 Ordered TypeCode	16-69 Pulse Output 27 [Hz]	32-11 User Unit Denominator
[7] >8.0 kHz<	Current Lim Ctrl, Filter Time	15-45 Actual Typecode String	16-70 Pulse Output 29 [Hz]	32-12 User Unit Numerator
[8] >10.0 kHz<	Energy Optimising	15-46 Drive Ordering No	16-71 Relay Output	32-67 Max. Tolerated Position Error
[9] >12.0kHz<	VE Level	15-48 LCP Id No	16-72 Counter A	32-69 PID Sample Time
[10] >16.0kHz<	AEO Minimum Magnetisation	15-49 SW ID Control Card	16-73 Counter B	32-80 Maximum Allowed Velocity
14-03 Overmodulation	>40-75%< *66%	15-50 SW ID Power Card	16-79 Analog Output AO45	<b>33-** Motion Control Adv. Settings</b>
[0] >Off<	>0-200%< *100%	15-51 Drive Serial Number	16-8* Fieldbus & FC Port	33-00 Force Home
*[1] >On<	Environment	15-53 Power Card Serial Number	33-01 Home Offset	33-02 Home Ramp Time
14-07 Dead Time Compensation Level	RFI Filter	15-6* Option Ident	33-03 Homing Velocity	33-04 Home Type
14-08 Damping Gain Factor	DC-Link Voltage Compensation	15-60 Option Mounted	33-41 Negative Software Limit	33-42 Positive Software Limit
14-09 Dead Time Bias Current Level	Fan Control	15-9* Parameter Info	33-43 Negative Software Limit Active	33-44 Positive Software Limit Active
<b>14-1* Mains On/Off</b>	Mains Failure	15-92 Defined Parameters	33-47 Target Position Window	<b>34-** Motion Control Data Readouts</b>
14-10 Mains Failure	>No function<	15-98 Drive Identification	34-01 PCD 1 Write For Application	34-02 PCD 2 Write For Application
[0] >No function<	>Constant-on mode<	15-99 Parameter Metadata	34-03 PCD 3 Write For Application	34-04 PCD 4 Write For Application
[1] >Ctrl. ramp-down<	>On-when-inverter-is-on-else-off	16-0* General Status	34-05 PCD 5 Write For Application	34-06 PCD 6 Write For Application
[2] >Ctrl. ramp-down, trip<	Mode<	16-00 Control Word	34-07 PCD 7 Write For Application	34-08 PCD 8 Write For Application
[3] >Coasting<	>Variable-speed mode<	16-01 Reference [Unit]	34-09 PCD 9 Write For Application	34-21 PCD 1 Read For Application
[4] >Kinetic back-up<	Output Filter	16-02 Reference [%]	34-22 PCD 2 Read For Application	
[5] >Kinetic back-up, trip<	Auto Derate	16-03 Status Word		
[6] >Alarm<	Function at Inverter Overload	16-09 Custom Readout		
[7] >Alarm, back-up, trip w recovery<	Trip	16-1* Motor Status		
14-11 Mains Voltage at Mains Fault	Derate	16-10 Input Voltage		
14-12 Function at Mains Imbalance	Min Switch Frequency	16-11 Power [hp]		
*[0] >Trip<	>2.0 kHz<	16-12 Motor Voltage		
[1] >Warning<	>3.0 kHz<			
[2] >Disabled<	>4.0 kHz<			
[3] >Derate<	>5.0 kHz<			
14-15 Kin. Backup Trip Recovery Level	>6.0 kHz<			
<b>14-2* Reset Functions</b>	>8.0 kHz<			
14-20 Reset Mode	>10.0 kHz<			
*[0] >Manual reset<	>12.0 kHz<			

34-23	PCD 3 Read For Application
33-24	PCD 4 Read For Application
33-25	PCD 5 Read For Application
33-26	PCD 6 Read For Application
33-27	PCD 7 Read For Application
33-28	PCD 8 Read For Application
33-29	PCD 9 Read For Application
33-30	PCD 10 Read For Application
34-56	Track Error
<b>37-*</b>	<b>Application Settings</b>
<b>37-0*</b>	<b>Application Mode</b>
37-00	Application Mode
<b>37-2*</b>	<b>Central Winder</b>
37-20	Winder Mode Selection
37-21	Tension Set Point
37-22	Taper Set Point
37-23	Partial Roll Diameter Value
37-24	Core1 Diameter
37-25	Core2 Diameter
37-26	Winder Jog Speed
37-27	TLD Low Limit
37-28	TLD High Limit
37-29	TLD Timer
37-30	TLDOnDelay
37-31	Diameter Limit Detector
37-32	Initial Diameter Measurement
37-33	Diameter Measurement Input
37-34	Reading at Core
37-35	Reading at Full Roll
37-36	Tension Set Point Input
37-37	Taper Set Point Input
37-38	Tension Feedback Input
37-39	Tension Feedback Type
37-40	Central Winder Cmd Src
37-41	Diameter Change Rate
37-42	Tapered Tension Change Rate
37-43	Diameter Calculator Min Speed
37-44	Line Acceleration Feed Forward
37-45	Line Speed Source
37-46	Winder Speed Match Scale
37-47	Tension PID Profile
37-48	Tension PID Proportional Gain
37-49	Tension PID Derivate Time
37-50	Tension PID Integral Time
37-51	Tension PID Out Limit
37-52	Tension PID Der Gain Limit
37-53	Tension PID Anti Windup
37-54	Winder Jog Reverse
37-55	Winder Jog Forward
37-56	New Diameter Select
37-57	Tension On/Off
37-58	Core Select
37-59	Diameter Reset



## 6 Application Examples

### 6.1.1 AMA

		Parameters	
FC		Function	Setting
+24 V	12	Parameter 1-29 Automatic Motor Adaptation (AMA)	[1] Enable complete AMA
D IN	18		
D IN	19	Parameter 5-12 Terminal 27 Digital Input	[2]* Coast inverse
COM	20		
D IN	27	* = Default value	
D IN	29	<b>Notes/comments:</b> Set parameter group 1-2* Motor Data according to motor specifications. <b>NOTICE</b> If terminal 12 and 27 are not connected, set parameter 5-12 Terminal 27 Digital Input to [0] No operation.	
D IN	32		
D IN	33		
+10 V	50		
A IN	53		
A IN	54		
COM	55		
A OUT	42		

Table 6.1 AMA with T27 Connected

### 6.1.2 Speed

		Parameters	
FC		Function	Setting
+24 V	12	Parameter 6-10 Terminal 53 Low Voltage	0.07 V*
D IN	18		
D IN	19	Parameter 6-11 Terminal 53 High Voltage	10 V*
COM	20		
D IN	27	Parameter 6-14 Terminal 53 Low Ref./Feedb. Value	0
D IN	29		
D IN	32	Parameter 6-15 Terminal 53 High Ref./Feedb. Value	1500
D IN	33		
+10 V	50	Parameter 6-19 Terminal 53 mode	[1] Voltage
A IN	53		
A IN	54	* = Default value	
COM	55	<b>Notes/comments:</b>	
A OUT	42		

Table 6.2 Analog Speed Reference (Voltage)

		Parameters	
FC		Function	Setting
+24 V	12	Parameter 6-12 Terminal 53 Low Current	4 mA*
D IN	18		
D IN	19	Parameter 6-13 Terminal 53 High Current	20 mA*
COM	20		
D IN	27	Parameter 6-14 Terminal 53 Low Ref./Feedb. Value	0
D IN	29		
D IN	32	Parameter 6-15 Terminal 53 High Ref./Feedb. Value	1500
D IN	33		
+10 V	50	Parameter 6-19 Terminal 53 mode	[0] current
A IN	53		
A IN	54	* = Default value	
COM	55	<b>Notes/comments:</b>	
A OUT	42		

Table 6.3 Analog Speed Reference (Current)

		Parameters	
FC		Function	Setting
+24 V	12	Parameter 6-10 Terminal 53 Low Voltage	0.07 V*
D IN	18		
D IN	19	Parameter 6-11 Terminal 53 High Voltage	10 V*
COM	20		
D IN	27	Parameter 6-14 Terminal 53 Low Ref./Feedb. Value	0
D IN	29		
D IN	32	Parameter 6-15 Terminal 53 High Ref./Feedb. Value	1500
D IN	33		
+10 V	50	Parameter 6-19 Terminal 53 mode	[1] voltage
A IN	53		
A IN	54	* = Default value	
COM	55	<b>Notes/comments:</b>	
A OUT	42		

Table 6.4 Speed Reference (Using a Manual Potentiometer)

		Parameters	
FC		Function	Setting
+24 V	12	Parameter 5-10 Terminal 18 Digital Input	[8] Start*
D IN	18		
D IN	19	Parameter 5-12 Terminal 27 Digital Input	[19] Freeze Reference
COM	20		
D IN	27		
D IN	29	Parameter 5-13 Terminal 29 Digital Input	[21] Speed Up
D IN	32		
D IN	33	Parameter 5-14 Terminal 32 Digital Input	[22] Speed Down
+10 V	50		
A IN	53		
A IN	54		
COM	55		
A OUT	42		
		*=Default value	
		Notes/comments:	

Table 6.5 Speed Up/Down

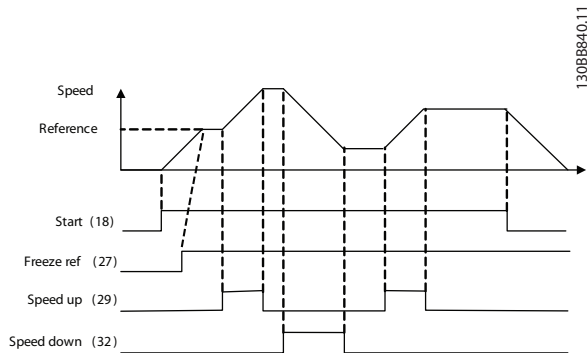

Illustration 6.1 Speed Up/Down

### 6.1.3 Start/Stop

		Parameters	
FC		Function	Setting
+24 V	12	Parameter 5-10 Terminal 18 Digital Input	[8] Start
D IN	18		
D IN	19	Parameter 5-11 Terminal 19 Digital Input	[10] Reversing*
COM	20		
D IN	27	Parameter 5-12 Terminal 27 Digital Input	[0] No operation
D IN	29		
D IN	32	Parameter 5-14 Terminal 32 Digital Input	[16] Preset ref bit 0
D IN	33	Parameter 5-15 Terminal 33 Digital Input	[17] Preset ref bit 1
+10 V	50	Parameter 3-10 Preset Reference	Preset ref. 0 25%
A IN	53		Preset ref. 1 50%
A IN	54		Preset ref. 2 75%
COM	55		Preset ref. 3 100%
A OUT	42		
		* = Default value	
		Notes/comments:	

Table 6.6 Start/Stop with Reversing and 4 Preset Speeds

### 6.1.4 External Alarm Reset

		Parameters	
		Function	Setting
		Parameter 5-11 Terminal 19 Digital Input	[1] Reset
		* = Default value	
Notes/comments:			

Table 6.7 External Alarm Reset

### 6.1.5 Motor Thermistor

**NOTICE**

To meet PELV insulation requirements, use reinforced or double insulation on the thermistors.

		Parameters	
		Function	Setting
		Parameter 1-90 Motor Thermal Protection	[2] Thermistor trip
		Parameter 1-93 Thermistor Source	[1] Analog input 53
		Parameter 6-19 Terminal 53 mode	[1] Voltage
* = Default value			
Notes/comments:			
If only a warning is needed, set parameter 1-90 Motor Thermal Protection to [1] Thermistor warning.			

Table 6.8 Motor Thermistor

### 6.1.6 SLC

		Parameters	
		Function	Setting
		Parameter 4-30 Motor Feedback Loss Function	[1] Warning
		Parameter 4-31 Motor Feedback Speed Error	100
		Parameter 4-32 Motor Feedback Loss Timeout	5 s
		Parameter 7-00 Speed PID Feedback Source	[2] MCB 102
		Parameter 17-11 Resolution (PPR)	1024*
		Parameter 13-00 SL Controller Mode	[1] On
		Parameter 13-01 Start Event	[19] Warning
		Parameter 13-02 Stop Event	[44] Reset key
		Parameter 13-10 Comparator Operand	[21] Warning no.
		Parameter 13-11 Comparator Operator	[1] ≈*
		Parameter 13-12 Comparator Value	90
		Parameter 13-51 SL Controller Event	[22] Comparator 0
		Parameter 13-52 SL Controller Action	[32] Set digital out A low
		Parameter 5-40 Function Relay	[80] SL digital output A
* = Default value			

Table 6.9 Using SLC to Set a Relay

	<p><b>Notes/comments:</b></p> <p>If the limit in the feedback monitor is exceeded, <i>warning 90 feedback monitor</i> is issued. The SLC monitors <i>warning 90 feedback monitor</i>. If <i>warning 90 feedback monitor</i> becomes <i>true</i>, relay 1 is triggered. External equipment could indicate that service is required. If the feedback error goes below the limit again within 5 s, the frequency converter continues and the warning disappears. But relay 1 persists until [Off/Reset] is pressed.</p>
--	--

Table 6.10 Using SLC to Set a Relay

## 7 Diagnostics and Troubleshooting

### 7.1 Warning and Alarm Types

Warning/ alarm type	Description
Warning	A warning indicates an abnormal operating condition that leads to an alarm. A warning stops when the abnormal condition is removed.
Alarm	An alarm indicates a fault that requires immediate attention. The fault always triggers a trip or trip lock. Reset the frequency converter after an alarm. Reset the frequency converter in any of 4 ways: <ul style="list-style-type: none"> <li>• Press [Reset].</li> <li>• Digital reset input command.</li> <li>• Serial communication reset input command.</li> <li>• Auto reset.</li> </ul>

#### Trip

A trip is an action by the frequency converter to suspend operation to prevent damages to the frequency converter and other equipment. When a trip occurs, the motor coasts to a stop. The frequency converter logic continues to operate and monitor the frequency converter status. After the fault condition is remedied, the frequency converter is ready for a reset.

#### Trip lock

A trip lock is an action by the frequency converter to suspend operation to prevent damages to the frequency converter and other equipment. When a trip lock occurs, the motor coasts to a stop. The frequency converter logic continues to operate and monitor the frequency converter status. The frequency converter starts a trip lock only when serious faults occur that can damage the frequency converter or other equipment. After the faults are fixed, cycle the input power before resetting the frequency converter.

### 7.2 Warning and Alarm Displays

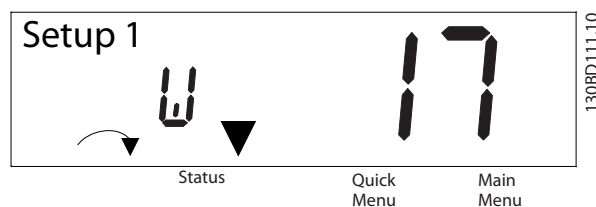

Illustration 7.1 Warning and Alarm Displays

An alarm or trip-lock alarm flashes in the display along with the alarm number.

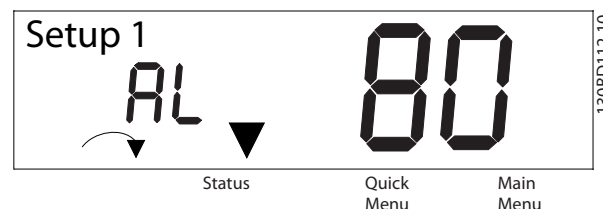

Illustration 7.2 Alarm/Trip Lock Alarm

In addition to the text and alarm code on the frequency converter display, there are 3 status indicator lights. The warning indicator light is yellow during an alarm. The alarm indicator light is red and flashing during an alarm.

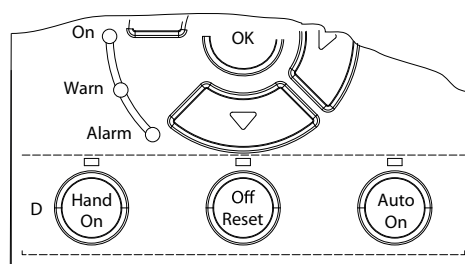

Illustration 7.3 Status Indicator Lights

### 7.3 Warning and Alarm Code List

An (X) marked in *Table 7.1* indicates that the warning or alarm has occurred. A warning precedes an alarm.

No.	Description	Warning	Alarm	Trip lock	Cause
2	Live zero error	X	X		Signal on terminal 53 or 54 is less than 50% of value set in <i>parameter 6-10 Terminal 53 Low Voltage</i> , <i>parameter 6-12 Terminal 53 Low Current</i> , <i>parameter 6-20 Terminal 54 Low Voltage</i> , and <i>parameter 6-22 Terminal 54 Low Current</i> .
3	No motor	X			No motor has been connected to the output of the frequency converter.
4	Mains phase loss <sup>1)</sup>	X	X	X	Missing phase on supply side, or the voltage imbalance is too high. Check the supply voltage.
7	DC overvoltage <sup>1)</sup>	X	X		Intermediate circuit voltage exceeds limit.
8	DC undervoltage <sup>1)</sup>	X	X		Intermediate circuit voltage drops below the voltage warning low limit.
9	Inverter overloaded	X	X		More than 100% load for too long.
10	Motor ETR overtemperature	X	X		Motor is too hot due to more than 100% load for too long.
11	Motor thermistor overtemperature	X	X		Thermistor or thermistor connection is disconnected.
12	Torque limit	X	X		Torque exceeds value set in either <i>parameter 4-16 Torque Limit Motor Mode</i> or <i>parameter 4-17 Torque Limit Generator Mode</i> .
13	Overcurrent	X	X	X	Inverter peak current limit is exceeded. For J1–J6 units, if this alarm occurs on power-up, check whether power cables are mistakenly connected to the motor terminals.
14	Ground fault	X	X	X	Discharge from output phases to ground.
16	Short circuit		X	X	Short circuit in motor or on motor terminals. For J7 units, if this alarm occurs on power-up, check whether power cables are mistakenly connected to the motor terminals.
17	Control word timeout	X	X		No communication to frequency converter.
25	Brake resistor short-circuited	X	X	X	Brake resistor is short-circuited, thus the brake function is disconnected.
26	Brake overload	X	X		The power transmitted to the brake resistor over the last 120 s exceeds the limit. Possible corrections: Decrease brake energy via lower speed or longer ramp time.
27	Brake IGBT/Brake chopper short-circuited	X	X	X	Brake transistor is short-circuited, thus brake function is disconnected.
28	Brake check	X	X		Brake resistor is not connected/working.
30	U phase loss		X	X	Motor phase U is missing. Check the phase.
31	V phase loss		X	X	Motor phase V is missing. Check the phase.
32	W phase loss		X	X	Motor phase W is missing. Check the phase.
34	Fieldbus fault	X	X		PROFIBUS communication issues have occurred.
35	Option fault		X		Fieldbus or option B detects internal errors.
36	Mains failure	X	X		This warning/alarm is only active if the supply voltage to the frequency converter is lost and <i>parameter 14-10 Mains Failure</i> is NOT set to [0] No Function.
38	Internal fault		X	X	Contact the local Danfoss supplier.
40	Overload T27	X			Check the load connected to terminal 27 or remove short-circuit connection.
41	Overload T29	X			Check the load connected to terminal 29 or remove short-circuit connection.
46	Gate drive voltage fault		X	X	

No.	Description	Warning	Alarm	Trip lock	Cause
47	24 V supply low	X	X	X	24 V DC may be overloaded.
51	AMA check $U_{nom}$ and $I_{nom}$		X		Wrong setting for motor voltage and/or motor current.
52	AMA low $I_{nom}$		X		Motor current is too low. Check the settings.
53	AMA big motor		X		The power size of the motor is too large for the AMA to operate.
54	AMA small motor		X		The power size of the motor is too small for the AMA to operate.
55	AMA parameter range		X		The parameter values of the motor are outside of the acceptable range. AMA does not run.
56	AMA interrupt		X		The AMA is interrupted.
57	AMA timeout		X		
58	AMA internal		X		Contact Danfoss.
59	Current limit	X	X		Frequency converter overload.
61	Encoder loss	X	X		
63	Mechanical brake low		X		Actual motor current has not exceeded release brake-current within start delay-time window.
65	Control card temp	X	X	X	The cut-out temperature of the control card is 80 °C.
67	Option change		X		A new option is detected or a mounted option is removed.
69	Power card temp	X	X	X	
80	Drive initialised to default value		X		All parameter settings are initialised to default settings.
87	Auto DC braking	X			Occurs in IT mains when the frequency converter coasts and the DC voltage is higher than 830 V. Energy on DC-link is consumed by the motor. This function can be enabled/disabled in <i>parameter 0-07 Auto DC Braking</i> .
88	Option detection		X	X	The option is removed successfully.
90	Feedback monitor	X	X		A feedback fault is detected by option B.
95	Broken belt	X	X		
101	Flow/pressure information missing		X	X	
120	Position control fault		X		
250	New spare part		X	X	
251	New type code		X	X	
252	Tension limit		X		
nw run	Not while running				Parameter can only be changed when the motor is stopped.
Err.	A wrong password was entered				Occurs when using a wrong password for changing a password-protected parameter.

**Table 7.1 Warnings and Alarms Code List**

1) These faults may be caused by mains distortions. Installing a Danfoss line filter may rectify this problem.

For diagnosis, read out the alarm words, warning words, and extended status words.

## 7.4 Error Code List

LCP-related errors are displayed in the format of **Err XX**, where XX indicates the error number. The LCP errors do not affect the operation of the frequency converter.

LCP error code	Description
Err 84	Communication between the LCP and the frequency converter is lost.
Err 85	The LCP key is disabled. One of the LCP keys is disabled in parameter group 0-4* LCP Keypad.
Err 86	Data copy failure: Occurs when data is copied from frequency converter to LCP, or from LCP to frequency converter ( <i>parameter 0-50 LCP Copy</i> ).
Err 87	Invalid LCP data: Occurs when data is being copied from LCP to frequency converter ( <i>parameter 0-50 LCP Copy</i> ).
Err 88	LCP data incompatible: Occurs when data is being copied from LCP to frequency converter ( <i>parameter 0-50 LCP Copy</i> ), typically because data is moved between frequency converters that have major software differences.
Err 89	An operation is issued via LCP to write a value to a parameter that is read-only.
Err 90	LCP, serial communication, or fieldbus communication attempts to update the same parameters at the same time.
Err 91	The parameter value that is input via the LCP is invalid.
Err 92	The parameter value that is input via the LCP exceeds limits.
Err 93	The LCP copy operation cannot be conducted when the frequency converter is running.
donE	A notification that the LCP Copy process is finished.
NWrun	The parameter cannot be changed while the frequency converter is running.
Err.	The password that is input via the LCP is incorrect.

Table 7.2 Error Code List

## 7.5 Troubleshooting

Symptom	Possible cause	Test	Solution
Motor not running	LCP stop	Check if [Off] has been pressed.	Press [Auto On] or [Hand On] (depending on operating mode) to run the motor.
	Missing start signal (standby)	Check <i>parameter 5-10 Terminal 18 Digital Input</i> for correct setting for terminal 18 (use default setting).	Apply a valid start signal to start the motor.
	Motor coast signal active (coasting)	Check <i>parameter 5-12 Terminal 27 Digital Input</i> for correct setting for terminal 27 (use default setting).	Apply 24 V on terminal 27 or program this terminal to <i>No operation</i> .
	Wrong reference signal source	Check the following: <ul style="list-style-type: none"> <li>The reference signal is local, remote, or bus reference?</li> <li>Preset reference is active?</li> <li>Terminal connection is correct?</li> <li>The scaling of terminals is correct?</li> <li>The reference signal is available?</li> </ul>	Program correct settings. Set preset reference active in parameter group 3-1* <i>References</i> . Check for correct wiring. Check scaling of terminals. Check reference signal.
Motor is running in the wrong direction	Motor rotation limit	Check that <i>parameter 4-10 Motor Speed Direction</i> is programmed correctly.	Program correct settings.
	Active reversing signal	Check if a reversing command is programmed for the terminal in parameter group 5-1* <i>Digital inputs</i> .	Deactivate reversing signal.
	Wrong motor phase connection	Change <i>parameter 1-06 Clockwise Direction</i>	



Symptom	Possible cause	Test	Solution
Motor is not reaching maximum speed	Frequency limits are set incorrectly	Check output limits in <i>parameter 4-14 Motor Speed High Limit [Hz]</i> and <i>parameter 4-19 Max Output Frequency</i>	Program correct limits.
	Reference input signal not scaled correctly	Check reference input signal scaling in <i>6-** Analog I/O mode</i> and parameter group <i>3-1* References</i> .	Program correct settings.
Motor speed is unstable	Possible incorrect parameter settings	Check the settings of all motor parameters, including all motor compensation settings. For closed-loop operation, check PID settings.	Check settings in parameter group <i>6-** Analog I/O mode</i> .
Motor runs roughly	Possible overmagnetisation	Check for incorrect motor settings in all motor parameters.	Check motor settings in parameter groups <i>1-2* Motor data</i> , <i>1-3* Adv motor data</i> , and <i>1-5* Load indep. setting</i> .
Motor does not brake	Possible incorrect settings in the brake parameters. Possible too short ramp-down times.	Check brake parameters. Check ramp time settings.	Check parameter group <i>2-0* DC brake</i> and <i>3-0* Reference limits</i> .
Open power fuses or circuit breaker trip	Phase-to-phase short	Motor or panel has a short phase-to-phase. Check motor and panel phase for shorts.	Eliminate any shorts detected.
	Motor overload	Motor is overloaded for the application.	Perform the start-up test and verify that motor current is within specifications. If motor current is exceeding nameplate full load current, the motor may run only with reduced load. Review the specifications for the application.
	Loose connections	Perform pre-startup check for loose connections.	Tighten loose connections.
Mains current imbalance greater than 3%	Problem with mains power (See <i>Alarm 4 Mains phase loss</i> description)	Rotate input power leads into the frequency converter 1 position: A to B, B to C, C to A.	If the imbalanced leg follows the wire, it is a power problem. Check mains supply.
	Problem with the frequency converter unit	Rotate input power leads into the frequency converter 1 position: A to B, B to C, C to A.	If the imbalanced leg stays on same input terminal, it is a problem with the unit. Contact the supplier.
Motor current imbalance greater than 3%	Problem with motor or motor wiring	Rotate output motor leads 1 position: U to V, V to W, W to U.	If the imbalanced leg follows the wire, the problem is in the motor or motor wiring. Check motor and motor wiring.
	Problem with the frequency converter unit	Rotate output motor leads 1 position: U to V, V to W, W to U.	If the imbalanced leg stays on same output terminal, it is a problem with the unit. Contact the supplier.
Acoustic noise or vibration (for example, a fan blade is making noise or vibrations at certain frequencies)	Resonances, for example, in the motor/fan system	Bypass critical frequencies by using parameters in parameter group <i>4-6* Speed Bypass</i> . Turn off overmodulation in <i>parameter 14-03 Overmodulation</i> . Increase resonance damping in <i>parameter 1-64 Resonance Dampening</i> .	Check if noise and/or vibration have been reduced to an acceptable limit.

Table 7.3 Troubleshooting

## 8 Specifications

### 8.1 Mains Supply 3x380–480 V AC

Frequency converter typical shaft output [kW]	HK37 0.37	HK55 0.55	HK75 0.75	H1K1 1.1	H1K5 1.5	H2K2 2.2	H3K0 3	H4K0 4	H5K5 5.5	H7K5 7.5
Enclosure protection rating IP20	J1	J1	J1	J1	J1	J1	J2	J2	J2	J3
<b>Output current</b>										
Shaft output [kW]	0.37	0.55	0.75	1.1	1.5	2.2	3	4	5.5	7.5
Continuous (3x380–440 V) [A]	1.2	1.7	2.2	3	3.7	5.3	7.2	9	12	15.5
Continuous (3x441–480 V) [A]	1.1	1.6	2.1	2.8	3.4	4.8	6.3	8.2	11	14
Intermittent (60 s overload) [A]	1.9	2.7	3.5	4.8	5.9	8.5	11.5	14.4	19.2	24.8
Continuous kVA (400 V AC) [kVA]	0.84	1.18	1.53	2.08	2.57	3.68	4.99	6.24	8.32	10.74
Continuous kVA (480 V AC) [kVA]	0.9	1.3	1.7	2.5	2.8	4.0	5.2	6.8	9.1	11.6
<b>Maximum input current</b>										
Continuous (3x380–440 V) [A]	1.2	1.6	2.1	2.6	3.5	4.7	6.3	8.3	11.2	15.1
Continuous (3x441–480 V) [A]	1.0	1.2	1.8	2.0	2.9	3.9	4.3	6.8	9.4	12.6
Intermittent (60 s overload) [A]	1.9	2.6	3.4	4.2	5.6	7.5	10.1	13.3	17.9	24.2
<b>Additional specifications</b>										
Maximum cable cross-section (mains, motor, brake, and load sharing) [mm <sup>2</sup> (AWG)]	4(12)									
Estimated power loss at rated maximum load [W] <sup>2)</sup>	20.88	25.16	30.01	40.01	52.91	73.97	94.81	115.5	157.54	192.83
Weight [kg], enclosure protection rating IP20	2.3	2.3	2.3	2.3	2.3	2.5	3.6	3.6	3.6	4.1
Efficiency [%] <sup>3)</sup>	96.2	97.0	97.2	97.4	97.4	97.6	97.5	97.6	97.7	98.0

Table 8.1 Mains Supply 3x380–480 V AC - Heavy Duty<sup>1)</sup>

Frequency converter typical shaft output [kW]	H11K 11	H15K 15	H18K 18.5	H22K 22	H30K 30	H37K 37	H45K 45	H55K 55	H75K 75
Enclosure protection rating IP20	J4	J4	J5	J5	J6	J6	J6	J7	J7
<b>Output current</b>									
Continuous (3x380–440 V) [A]	23	31	37	42.5	61	73	90	106	147
Continuous (3x441–480 V) [A]	21	27	34	40	52	65	77	96	124
Intermittent (60 s overload) [A]	34.5	46.5	55.5	63.8	91.5	109.5	135	159	220.5
Continuous kVA (400 V AC) [kVA]	15.94	21.48	25.64	29.45	42.3	50.6	62.4	73.4	101.8
Continuous kVA (480 V AC) [kVA]	17.5	22.4	28.3	33.3	43.2	54.0	64.0	79.8	103.1
<b>Maximum input current</b>									
Continuous (3x380–440 V) [A]	22.1	29.9	35.2	41.5	57	70.3	84.2	102.9	140.3
Continuous (3x441–480 V) [A]	18.4	24.7	29.3	34.6	49.3	60.8	72.7	88.8	121.1
Intermittent (60 s overload) [A]	33.2	44.9	52.8	62.3	85.5	105.5	126.3	154.4	210.5
<b>Additional specifications</b>									
Maximum cable size (mains, motor, brake) [mm <sup>2</sup> (AWG)]	16(6)				50(1/0)				85(3/0)
Estimated power loss at rated maximum load [W] <sup>2)</sup>	289.53	393.36	402.83	467.52	630	848	1175	1250	1507
Weight [kg], enclosure protection rating IP20	9.4	9.5	12.3	12.5	22.4	22.5	22.6	37.3	38.7
Efficiency [%] <sup>3)</sup>	97.8	97.8	98.1	97.9	98.1	98.0	97.7	98.0	98.2

**Table 8.2 Mains Supply 3x380–480 V AC - Heavy Duty<sup>1)</sup>**

Frequency converter typical shaft output [kW]	Q11K 11	Q15K 15	Q18K 18.5	Q22K 22	Q30K 30	Q37K 37	Q45K 45	Q55K 55	Q75K 75
Enclosure protection rating IP20	J4	J4	J5	J5	J6	J6	J6	J7	J7
<b>Output current</b>									
Continuous (3x380–440 V) [A]	23	31	37	42.5	61	73	90	106	147
Continuous (3x441–480 V) [A]	21	27	34	40	52	65	77	96	124
Intermittent (60 s overload) [A]	25.3	34.1	40.7	46.8	67.1	80.3	99	116.6	161.7
Continuous kVA (400 V AC) [kVA]	15.94	21.48	25.64	29.45	42.3	50.6	62.4	73.4	101.8
Continuous kVA (480 V AC) [kVA]	17.5	22.4	28.3	33.3	43.2	54.0	64.0	79.8	103.1
<b>Maximum input current</b>									
Continuous (3x380–440 V) [A]	22.1	29.9	35.2	41.5	57	70.3	84.2	102.9	140.3
Continuous (3x441–480 V) [A]	18.4	24.7	29.3	34.6	49.3	60.8	72.7	88.8	121.1
Intermittent (60 s overload) [A]	24.3	32.9	38.7	45.7	62.7	77.3	92.6	113.2	154.3
<b>Additional specifications</b>									
Maximum cable size (mains, motor, brake) [mm <sup>2</sup> (AWG)]	16(6)				50(1/0)				85(3/0)
Estimated power loss at rated maximum load [W] <sup>2)</sup>	289.53	393.36	402.83	467.52	630	848	1175	1250	1507
Weight [kg], enclosure protection rating IP20	9.4	9.5	12.3	12.5	22.4	22.5	22.6	37.3	38.7
Efficiency [%] <sup>3)</sup>	97.8	97.8	98.1	97.9	98.1	98.0	97.7	98.0	98.2

**Table 8.3 Mains Supply 3x380–480 V AC - Normal Duty<sup>1)</sup>**

1) Heavy duty=150–160% current during 60 s, Normal duty=110% current during 60 s.

2) The typical power loss is at nominal load conditions and expected to be within ±15% (tolerance relates to variety in voltage and cable conditions).

Values are based on a typical motor efficiency (IE2/IE3 border line). Motors with lower efficiency add to the power loss in the frequency converter and motors with high efficiency reduce power loss.

Applies for dimensioning of frequency converter cooling. If the switching frequency is higher than the default setting, the power losses may rise. LCP and typical control card power consumptions are included. Further options and customer load may add up to 30 W to the losses (though typical only 4 W extra for a fully loaded control card, fieldbus, or options for slot B).

For power loss data according to EN 50598-2, refer to [www.danfoss.com/vlteneryefficiency](http://www.danfoss.com/vlteneryefficiency).

3) Measured using 5 m screened motor cables at rated load and rated frequency for enclosure sizes J1–J5, and using 33 m screened motor cables at rated load and rated frequency for enclosure sizes J6 and J7. For energy efficiency class, see the Ambient Conditions section in chapter 8.2 General Technical Data. For part load losses, see [www.danfoss.com/vlteneryefficiency](http://www.danfoss.com/vlteneryefficiency).

## 8.2 General Technical Data

### Mains supply (L1, L2, L3)

Supply terminals	L1, L2, L3
Supply voltage	380–480 V: -15% (-25%) <sup>1)</sup> to +10%

1) The frequency converter can run at -25% input voltage with reduced performance. The maximum output power of the frequency converter is 75% in case of -25% input voltage and 85% in case of -15% input voltage.

Full torque cannot be expected at mains voltage lower than 10% below the lowest rated supply voltage of the frequency converter.

Supply frequency	50/60 Hz ±5%
Maximum imbalance temporary between mains phases	3.0% of rated supply voltage
True power factor ( $\lambda$ )	≥0.9 nominal at rated load
Displacement power factor ( $\cos \phi$ )	near unity (>0.98)
Switching on input supply L1, L2, L3 (power-ups) ≤7.5 kW	Maximum 2 times/minute
Switching on input supply L1, L2, L3 (power-ups) 11–75 kW	Maximum 1 time/minute

The unit is suitable for use on a circuit capable of delivering less than 100000 RMS symmetrical Amperes, 480 V maximum.

### Motor output (U, V, W)

Output voltage	0–100% of supply voltage
Output frequency	0–500 Hz
Output frequency in VVC <sup>+</sup> Mode	0–200 Hz
Switching on output	Unlimited
Ramp time	0.05–3600 s

### Torque characteristics

Starting torque (constant torque)	Maximum 160% for 60 s <sup>1)</sup>
Overload torque (constant torque)	Maximum 160% for 60 s <sup>1)</sup>
Starting torque (variable torque)	Maximum 110% for 60 s <sup>1)</sup>
Overload torque (variable torque)	Maximum 110% for 60 s
Starting current	Maximum 200% for 1 s
Torque rise time in VVC <sup>+</sup> (independent of $f_{sw}$ )	10 ms

1) Percentage relates to the nominal torque.

2) The torque response time depends on application and load, but generally, the torque step from 0 to reference is 4–5 x torque rise time.

### Cable lengths and cross-sections<sup>1)</sup>

Maximum motor cable length, screened	50 m
Maximum motor cable length, unscreened	0.37–22 kW: 75 m, 30–75 kW: 100 m
Maximum cross-section to control terminals, flexible/rigid wire	2.5 mm <sup>2</sup> /14 AWG
Minimum cross-section to control terminals	0.55 mm <sup>2</sup> /30 AWG

1) For power cables, see Table 8.1 to Table 8.3.

Digital inputs

Programmable digital inputs	7
Terminal number	18, 19, 27 <sup>1)</sup> , 29 <sup>1)</sup> , 32, 33, 31
Logic	PNP or NPN
Voltage level	0–24 V DC
Voltage level, logic 0 PNP	< 5 V DC
Voltage level, logic 1 PNP	> 10 V DC
Voltage level, logic 0 NPN	> 19 V DC
Voltage level, logic 1 NPN	< 14 V DC
Maximum voltage on input	28 V DC
Pulse frequency range	4 Hz–32 kHz
(Duty cycle) minimum pulse width	4.5 ms
Input resistance, $R_i$	approximately 4 k $\Omega$

1) Terminals 27 and 29 can also be programmed as output.

Analog inputs

Number of analog inputs	2
Terminal number	53, 54
Modes	Voltage or current
Mode select	software
Voltage level	0–10 V
Input resistance, $R_i$	approximately 10 k $\Omega$
Maximum voltage	-15 to +20 V
Current level	0/4 to 20 mA (scaleable)
Input resistance, $R_i$	approximately 200 $\Omega$
Maximum current	30 mA
Resolution for analog inputs	11 bit
Accuracy of analog inputs	Maximum error 0.5% of full scale
Bandwidth	100 Hz

The analog inputs are galvanically isolated from the supply voltage (PELV) and other high-voltage terminals.

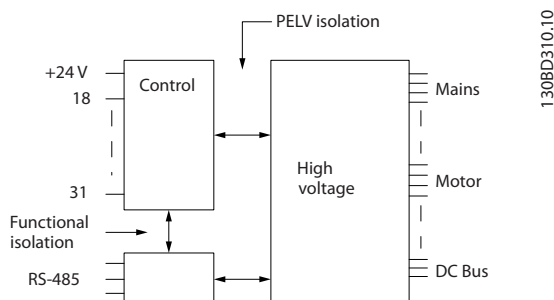

Illustration 8.1 Analog Inputs

Pulse inputs

Programmable pulse inputs	2
Terminal number pulse	29, 33
Maximum frequency at terminal 29, 33	32 kHz (push-pull driven)
Maximum frequency at terminal 29, 33	5 kHz (open collector)
Minimum frequency at terminal 29, 33	4 Hz
Voltage level	see section on digital input
Maximum voltage on input	28 V DC
Input resistance, $R_i$	approximately 4 k $\Omega$
Pulse input accuracy (0.1–1 kHz)	Maximum error: 0.1% of full scale
Pulse input accuracy (1–32 kHz)	Maximum error: 0.05% of full scale

**Analog outputs**

Number of programmable analog outputs	2
Terminal number	45, 42
Current range at analog output	0/4–20 mA
Maximum resistor load to common at analog output	500 Ω
Accuracy on analog output	Maximum error: 0.8% of full scale
Resolution on analog output	10 bit

*The analog output is galvanically isolated from the supply voltage (PELV) and other high-voltage terminals.*

**Control card, RS485 serial communication**

Terminal number	68 (P, TX+, RX+), 69 (N, TX-, RX-)
Terminal number 61	Common for terminals 68 and 69

*The RS485 serial communication circuit is galvanically isolated from the supply voltage (PELV).*

**Digital outputs**

Programmable digital/pulse outputs	2
Terminal number	27, 29 <sup>1)</sup>
Voltage level at digital/frequency output	0–24 V
Maximum output current (sink or source)	40 mA
Maximum load at frequency output	1 kΩ
Maximum capacitive load at frequency output	10 nF
Minimum output frequency at frequency output	4 Hz
Maximum output frequency at frequency output	32 kHz
Accuracy of frequency output	Maximum error: 0.1% of full scale
Resolution of frequency output	10 bit

*1) Terminal 27 and 29 can also be programmed as input.*

*The digital output is galvanically isolated from the supply voltage (PELV) and other high-voltage terminals.*

**Control card, 24 V DC output**

Terminal number	12
Maximum load	100 mA

*The 24 V DC supply is galvanically isolated from the supply voltage (PELV), but has the same potential as the analog and digital inputs and outputs.*

**Relay outputs**

Programmable relay outputs	2
Relay 01	01–03 (NC), 01–02 (NO), 04–06 (NC), 04–05 (NO)
Maximum terminal load (AC-1) <sup>1)</sup> on 01–02/04–05 (NO) (Resistive load)	250 V AC, 3 A
Maximum terminal load (AC-15) <sup>1)</sup> on 01–02/04–05 (NO) (Inductive load @ cosφ 0.4)	250 V AC, 0.2 A
Maximum terminal load (DC-1) <sup>1)</sup> on 01–02/04–05 (NO) (Resistive load)	30 V DC, 2 A
Maximum terminal load (DC-13) <sup>1)</sup> on 01–02/04–05 (NO) (Inductive load)	24 V DC, 0.1 A
Maximum terminal load (AC-1) <sup>1)</sup> on 01–03/04–06 (NC) (Resistive load)	250 V AC, 3 A
Maximum terminal load (AC-15) <sup>1)</sup> on 01–03/04–06 (NC) (Inductive load @ cosφ 0.4)	250 V AC, 0.2 A
Maximum terminal load (DC-1) <sup>1)</sup> on 01–03/04–06 (NC) (Resistive load)	30 V DC, 2 A
Minimum terminal load on 01–03 (NC), 01–02 (NO)	24 V DC 10 mA, 24 V AC 20 mA

*1) IEC 60947 t 4 and 5*

*The relay contacts are galvanically isolated from the rest of the circuit by reinforced isolation.*

**Control card, +10 V DC output**

Terminal number	50
Output voltage	10.5 V ±0.5 V
Maximum load	15 mA

*The 10 V DC supply is galvanically isolated from the supply voltage (PELV) and other high-voltage terminals.*

**Control characteristics**

Resolution of output frequency at 0–500 Hz	±0.003 Hz
System response time (terminals 18, 19, 27, 29, 32, and 33)	≤2 ms
Speed control range (open loop)	1:100 of synchronous speed
Speed accuracy (open loop)	±0.5% of nominal speed
Speed accuracy (closed loop)	±0.1% of nominal speed

All control characteristics are based on a 4-pole asynchronous motor.

**Ambient Conditions**

Enclosure sizes J1–J7	IP20
Vibration test, all enclosure sizes	1.0 g
Relative humidity	5–95% (IEC 721-3-3; Class 3K3 (non-condensing) during operation)
Aggressive environment (IEC 60068-2-43) H <sub>2</sub> S test	Class Kd
Test method according to IEC 60068-2-43 H <sub>2</sub> S (10 days)	
Ambient temperature (at 60 AVM switching mode)	
- with derating	Maximum 55 °C <sup>1)</sup>
- at full continuous output current with some power size	Maximum 50 °C
- at full continuous output current	Maximum 45 °C
Minimum ambient temperature during full-scale operation	0 °C
Minimum ambient temperature at reduced performance	-10 °C
Temperature during storage/transport	-25 to +65/70 °C
Maximum altitude above sea level without derating	1000 m
Maximum altitude above sea level with derating	3000 m
EMC standards, emission	EN 61800-3, EN 61000-3-2, EN 61000-3-3, EN 61000-3-11, EN 61000-3-12, EN 61000-6-3/4, EN 55011, IEC 61800-3 EN 61800-3, EN 61000-6-1/2, EN 61000-4-2,
EMC standards, immunity	EN 61000-4-3, EN 61000-4-4, EN 61000-4-5, EN 61000-4-6
Energy efficiency class <sup>1)</sup>	IE2

1) Determined according to EN 50598-2 at:

- Rated load.
- 90% rated frequency.
- Switching frequency factory setting.
- Switching pattern factory setting.

**Control card performance**

Scan interval	1 ms
---------------	------

**Protection and features**

- Electronic thermal motor protection against overload.
- Temperature monitoring of the heat sink ensures that the frequency converter trips when the temperature reaches a predefined level. An overload temperature cannot be reset until the temperature of the heat sink is below the temperature limit.
- The frequency converter is protected against short circuits on motor terminals U, V, W.
- If a mains phase is missing, the frequency converter trips or issues a warning (depending on the load and parameter setting).
- Monitoring of the intermediate circuit voltage ensures that the frequency converter trips when the intermediate circuit voltage is too low or too high.
- The frequency converter is protected against ground faults on motor terminals U, V, W.



### 8.3 Fuses

Use fuses and/or circuit breakers on the supply side to protect service personnel and equipment from injuries and damage in case of component breakdown inside the frequency converter (first fault).

#### Branch circuit protection

Protect all branch circuits in an installation, switch gear, and machines against short circuit and overcurrent according to national/international regulations.

#### **NOTICE**

The recommendations do not cover branch circuit protection for UL.

Table 8.4 lists the recommended fuses that have been tested.

Enclosure size	Power [kW]	CE compliance fuse
J1	0.37–1.1	gG-10
	1.5	
	2.2	
J2	3.0	gG-25
	4.0	
	5.5	
J3	7.5	gG-32
J4	11–15	gG-50
J5	18.5	gG-80
	22	
J6	30	gG-125
	37	
	45	
J7	55	aR-250
	75	

Table 8.4 CE Fuse, 380–480 V, Enclosure Sizes J1–J7

#### **WARNING**

##### PERSONAL INJURY AND EQUIPMENT DAMAGE RISK

Malfunction or failing to follow the recommendations may result in personal risk and damage to the frequency converter and other equipment.

- Select fuses according to recommendations. Possible damages can be limited to be inside the frequency converter.

#### **NOTICE**

Using fuses or circuit breakers is mandatory to ensure compliance with IEC 60364 for CE.

Danfoss recommends using the fuses in Table 8.4 on a circuit capable of delivering 100000 A<sub>rms</sub> (symmetrical), 380–480 V depending on the frequency converter voltage rating. With the proper fusing, the frequency converter short-circuit current rating (SCCR) is 100000 A<sub>rms</sub>.

### 8.4 Connection Tightening Torques

Make sure to use the right torques when tightening all electrical connections. Too low or too high torque may cause electrical connection problems. Use a torque wrench to ensure that correct torques are applied.

Enclosure size	Power [kW]	Torque [Nm]					
		Mains	Motor	DC connection	Brake	Ground	Relay
J1	0.37–2.2	0.8	0.8	0.8	0.8	3	0.5
J2	3.0–5.5	0.8	0.8	0.8	0.8	3	0.5
J3	7.5	0.8	0.8	0.8	0.8	3	0.5
J4	11–15	1.2	1.2	1.2	1.2	1.6	0.5
J5	18.5–22	1.2	1.2	1.2	1.2	1.6	0.5
J6	30–45	3.5	3.5	3.5	–	2.5	0.5
J7	55	12	12	12	–	2.5	0.5
J7	75	14	14	14	–	2.5	0.5

Table 8.5 Tightening Torques

**Index**

**A**

AC waveform..... 3

AMA with T27 connected..... 39

Ambient condition..... 54

Analog input..... 52

Analog output..... 53

Application example..... 39

Approval..... 3

Automatic motor adaptation..... 14

**B**

Branch circuit protection..... 55

**C**

Cable length..... 51

Clearance requirement..... 15

Control cable..... 21

Control card

  +10 V DC output..... 53

  Performance..... 54

  RS485 serial communication..... 53

Control characteristic..... 54

Control system..... 3

Control terminal..... 45

Control wiring..... 18

Cross-section..... 51

**D**

Derating..... 15, 54

Digital input..... 14, 52

Digital output..... 53

Discharge time..... 7

**E**

Electrical noise..... 18

EMC..... 54

Energy efficiency..... 48, 49, 50

Energy efficiency class..... 54

External controller..... 3

External interlock..... 14

**F**

Floating delta..... 19

Fuse..... 55

**G**

Ground connection..... 18

Ground loop..... 21

Ground wire..... 18

Grounded delta..... 19

Grounding..... 18, 19

**H**

High altitude..... 8

High voltage..... 7

**I**

IEC 61800-3..... 19, 54

Induced voltage..... 18

Input power..... 18

Input signal..... 21

Installation..... 15

Isolated mains..... 19

**L**

Leakage current..... 8

Load sharing..... 7

**M**

Main menu..... 25

Mains supply (L1, L2, L3)..... 51

Mains supply data..... 48

Menu key..... 23

**Motor**

  cable..... 18

  current..... 14

  data..... 14

  output..... 51

  power..... 18

  protection..... 18, 54

  status..... 3

  wiring..... 18

Multiple frequency converters..... 18

**N**

Navigation key..... 23

Noise isolation..... 18

Numeric display..... 23

**O**

Open loop..... 54

Operation key..... 23

Optional equipment..... 3, 19

Output current..... 53  
 Overload protection..... 18

**P**

PELV..... 8, 41, 53  
 Power connection..... 18  
 Power factor..... 19  
 PROFIBUS..... 31  
 Programming..... 14  
 Protection and feature..... 54  
 Pulse input..... 52

**Q**

Qualified personnel..... 7  
 Quick menu..... 27

**R**

Relay output..... 53  
 Remote command..... 3  
 Reset..... 43, 54  
 RFI filter..... 19

**S**

Safety..... 8  
 Screened control cable..... 21  
 Serial communication..... 3, 21, 22, 43  
 Shielded cable..... 18  
 Specification..... 15, 22  
 Specifications..... 48  
 Speed reference..... 39  
 Supply voltage..... 53  
 System feedback..... 3

**T**

Technical data..... 51  
 Terminal programming..... 21  
 Terminal tightening torque..... 56  
 Thermistor..... 41  
 Torque characteristic..... 51  
 Trip function..... 18  
 Troubleshooting..... 43

**U**

Unintended start..... 7

**V**

Voltage level..... 52

**W**

Warning and alarm list..... 45  
 Wire size..... 18





.....  
Danfoss can accept no responsibility for possible errors in catalogues, brochures and other printed material. Danfoss reserves the right to alter its products without notice. This also applies to products already on order provided that such alterations can be made without subsequential changes being necessary in specifications already agreed. All trademarks in this material are property of the respective companies. Danfoss and the Danfoss logotype are trademarks of Danfoss A/S. All rights reserved.  
.....

Danfoss A/S  
Ulsnaes 1  
DK-6300 Graasten  
vlt-drives.danfoss.com

